

Policies

Course Info

The EECS 16 series (Designing Information Devices and Systems) is a pair of freshman-level courses introducing students to EECS, with a particular emphasis on how we deal with systems interacting with the world from an information point of view. Mathematical modeling is an important theme throughout these courses, and students will learn many conceptual tools along the way. Throughout this series, generally applicable concepts and techniques are motivated by, and rooted in, specific exemplary application domains. Students should understand why they are learning something.

EECS 16A focuses on modeling as abstraction -- a way to see only the important and relevant underlying structure in a problem -- and introduces the basics of linear modeling, largely from a "static" and deterministic point of view. EECS 16B deepens the understanding of linear modeling and introduces dynamics and control, along with additional applications. Finally, EECS 70 (which can be thought of as the third course in this sequence --- except without any labs), introduces additional discrete structures for modeling problems, and brings in probability.

In EECS 16A in particular, we will use the application domains of imaging and tomography, touchscreens, and GPS and localization to motivate and inspire. Along the way, we will learn the basics of linear algebra and, more importantly, the linear-algebraic way of looking at the world. We will emphasize modeling and using linear structures to solve problems---not on how to do computations per se. We will learn about linear circuits, not merely as a powerful and creative way to help connect the physical world to what we can process computationally, but also as an exemplar of linearity and as a vehicle for learning how to do design. Circuits also provide a concrete setting in which to learn the key concept of "equivalence" --- an important aspect of abstraction. Our hope is that the concepts you learn in EECS 16A will help you as you tackle more advanced courses and will help form a solid conceptual framework that will help you learn throughout your career.

Grade Breakdown

- Homework: 16%
- Labs: 16%
- Midterm 1: 17%
- Midterm 2: 17%
- Final: 34%

Sustained Effort and Exam Clobber Policy

This course spans a fairly broad set of ideas and concepts within a short period of time, and hence sustained and consistent effort and investment are critical to your success in this class. Similarly, by far the most common operating mode we have observed in previous students who struggled and/or failed this class was attempting to do the bare minimum in general and then catch up/cram right before the exams.

In order to formally encourage all of you to maintain the sustained effort that we have observed to be critical to success, this semester we will be adopting a new policy regarding exam clobbering, participation, and effort. Specifically, exam clobbering will be given only to students who **(1)** attend at least 75% of the discussions (not including discussions in the first week of class) **and (2)** either submit no more than 1 late assignment (whether this is the homework itself, or the self-grade for that homework - more details to follow), or contribute by posting/answering relevant (as judged by the course staff) technical questions on Piazza at least 10 times over the course of the semester. Exam clobbering in this context means that if you perform better on one of the chronologically later exams as compared to one of the earlier ones, the score(s) from the later exam(s) can improve the effective score on your earlier exam(s). The specific details of how this clobbering is done will not be released, but in the past, it has made a substantial difference in many previous students' overall grade. Please note that even though lecture attendance was not included (for logistical reasons) in the criteria for clobbering eligibility, we do strongly encourage you to attend lecture in person, or at a minimum watch the webcasts (at a reasonable playback rate and without other distractions) as soon as they become available.

Homework Party

Most Fridays there will be a "homework party" in 144MA Cory from 3pm-7pm. Homework party is optional but highly encouraged.

GSIs, readers, and occasionally the instructors will be present in shifts to answer any homework questions. Students are expected to help each other out, and if desired, form ad-hoc "pickup" homework groups in the style of a pickup basketball game. We highly encourage students to attend homework party.

Homework Grading

The primary way that the homework will be graded is by yourselves. **Homeworks are usually due on Monday night at 11:59 PM.** You need to turn in both your code and written solutions in the form of a .ipynb file and a .pdf file consisting of your written-up solutions that also includes an attached pdf "printout" of your code. **Any homework submissions that are turned in without both the .ipynb file and a .pdf of the solutions along with the code "printout" (or screenshot) attached will receive a zero on the coded iPython (a.k.a. Jupyter) notebook portions of the homework. Submissions after 11:59 PM will not be accepted.** If you have any questions about the format of a homework submission, please go to office hours or homework party.

After the HW deadline, official solutions will be posted online. You will then be expected to read them and enter your own scores and comments for every part of every problem in the homework on a simple coarse scale:

- 0** = Didn't attempt or very very wrong,
- 2** = Got started and made some progress, but went off in the wrong direction or with no clear direction,
- 5** = Right direction and got half-way there,
- 8** = Mostly right but a minor thing missing or wrong,
- 10** = 100% correct.

Note: You must justify every self-grade score with a comment. If you are really confused about how to grade a particular problem, you should post on [Piazza](#). This is not supposed to be a stressful process.

Your self-grades will be due on the Thursday following the homework deadline at 11:59 PM sharp. We will accept late self-grades up to a week after the original homework deadline for half credit on the associated homework assignment. If you don't enter a proper grade by this deadline, you are giving yourself a zero on that assignment. Merely doing the homework is not enough, you must do the homework; turn it in on time; read the solutions; do the self-grade; and turn it in on time. **Unless all of these steps are done, you will get a zero for that assignment.**

We will drop the lowest homework score from your final grade calculation. This drop is meant for emergencies. If you use this drop half-way into the semester, and request another, we cannot help you.

Just like we encourage you to use a study group for doing your homework, we strongly encourage you to have others help you in grading your assignments while you help grade theirs. This will also help you avoid self-favoritism.

Course readers are going to be grading and sending you occasional comments. Because we have reader grades, we will catch any attempts at trying to inflate your own scores. This will be considered cheating and is definitely not worth the risk. Your own scores will be used in computing your final grade for the course, adjusted by taking into account reader scores so that everyone is fairly graded effectively on the same scale. For example, if we notice that you tend to give yourself 5s on questions where readers looking at your homeworks tend to give you 8s, we will apply an upward correction to adjust.

Reader grades will be released on Gradescope about one week after the homework deadline. Readers grade questions either on a "coarse" or "fine" scale for each homework part. Coarsely graded question parts are worth a single point and are based on effort. Finely graded question parts are worth a total of 10 points and are graded using the same self-grading rubric above. Homework regrade requests are typically due on Gradescope within 72 hours of reader grades being released. If a regrade request is submitted for a part of a question on the homework, the grader reserves the right to regrade the entire homework and could potentially take points off.

Your final homework score will be kept internal to the staff.

If you have any questions, please ask on [Piazza](#).

Lab and Discussion Section Policies

Labs for this class are not open section, **you must go to your assigned lab section.** If you finish the lab early, we encourage you to help other groups debug their lab. This will help you learn the material better and contribute towards a better learning experience for everyone.

You should aim to get checked-off by the end of the lab. If you don't make it, you have until the next lab to get checked-off. While labs are not meant to be burdensome, they are an essential part of the course. We have the following strict grading policy for labs: **if you complete all the labs, you will receive full lab credit. If you fail to complete one lab, you will receive 15/16 lab credit. If you miss two or three labs without prior excuse, you will receive half credit. If you miss four or more labs without prior excuse, you will get an F in the class.**

Number of Missed Labs	What Happens?
-----------------------	---------------

0	You get full lab credit - 16/16
1	You get almost full lab credit - 15/16
2 or 3	You get half lab credit - 8/16
4 or more	You Fail the class - final letter grade: F

Some lab sections are “buffer labs.” “Buffer labs” are a several day period in which no new labs begin. During buffer lab sections, you may get checked off for **only one lab** that occurred during that module. No other labs may be checked off. You may attend any buffer lab held during that period.

Wires on lab breadboards must be planar. Lab staff will ask students to redo their circuits before debugging them if the wires are non-planar. The definition of planar wires on a breadboard is shown below:

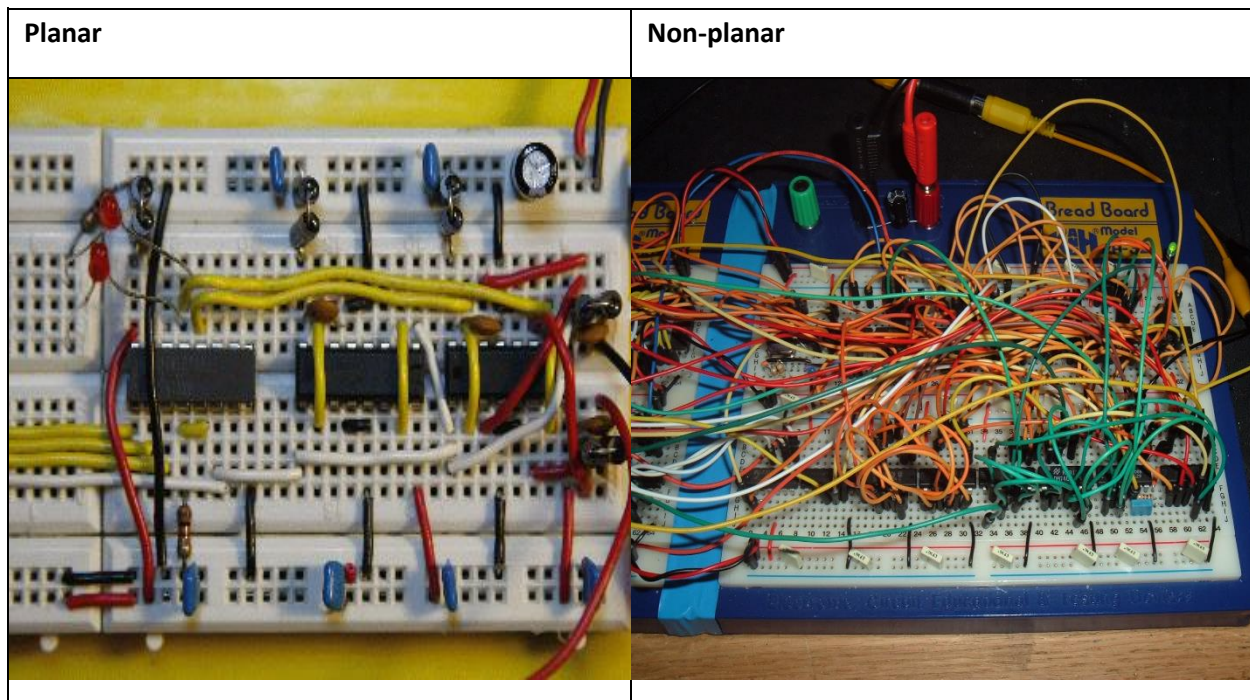

You may go to any discussion section, however, seating priority for any discussion section goes to those officially enrolled. All other students are allowed to remain in the section at the discretion of the discussion TA in charge of that section. We encourage you to go to the same discussion section every week so that the TAs can get to know you personally.

Exam Policies

The 16A Fall 2017 semester will have two midterms and one final. The midterm times will be October 4th, 2017 from 7pm to 9pm and November 6th, 2017 from 7pm to 9pm. The final will be held during the designated final exam slot released by campus. Makeup exams will not be scheduled.

Please plan for exams at these times and **email the Head GSI during the first two weeks of the semester per university policy if you know about any exam conflicts.** If an emergency arises that

conflicts with the exam times, email the Head GSI as soon as possible. Emergency exam conflicts will be handled on a case-by-case basis. Exam conflicts originating from a lecture conflict will not be accommodated.

On exam day, you must bring your Cal student ID to your exam location. Locations and logistics will be posted on [Piazza](#) closer to the exam dates. If you do not take your exam in the correct location, a large penalty will be applied to your exam score. Additionally, regrade requests on Gradescope are typically due within a week of exams being released on Gradescope. Late regrade requests will not be considered. If a regrade request is submitted for a part of a question on the exam, the grader reserves the right to regrade the entire exam and could potentially take points off.

Excuses

Any excuse should be emailed to the Head GSI. Email the excuse request out as soon as possible.

Excuses will be handled on a case-by-case basis. Since there is one homework drop, missing homework is rarely excused. Lab and exam excuses are given more consideration. Examples of situations that merit an exam or lab excuse are medical emergencies and family emergencies.

Course Communication

The instructors and TAs will post announcements, clarifications, hints, etc. on Piazza. Hence you must check the EE16A Piazza page frequently throughout the term. (You should already have access to the EE16A Fall 2017 forum. If you do not, please let us know.)

If you have a question, your best option is to post a message on [Piazza](#). The staff (instructors and TAs) will check the forum regularly, and if you use the forum, other students will be able to help you too. When using the forum, please avoid off-topic discussions, and please do not post answers to homework questions before the homework is due. Also, always look for a convenient category to post the question to (for example, each homework will have its own category, so please post there). That will ensure you get the answer faster.

If your question is personal or not of interest to other students, you may mark your question as private on Piazza, so only the instructors will see it. If you wish to talk with one of us individually, you are welcome to come to our office hours. Please reserve email for the questions you can't get answered in office hours, in discussion sections, or through the forum.

It can be challenging for the instructors to gauge how smoothly the class is going. We always welcome any feedback on what we could be doing better. If you would like to send anonymous comments or criticisms, please feel free to use an anonymous remailer to avoid revealing your identity.

Collaboration/Cheating

We encourage you to work on homework problems in study groups of two to four people; however, you must always write up the solutions on your own. Similarly, you may use books or online resources to help solve homework problems, but you must always credit all such sources in your writeup, and you must never copy material verbatim. **Using previous EE 16A homework and lab solutions is strictly prohibited, and will result in a case filed against you with the Office of Student Conduct.**

Please note that online communication mediums outside of Piazza should not be used to discuss assignment content. In general, use Piazza to discuss content. The only limited exceptions to this are online communication mediums between you and the collaborating individuals explicitly listed on your homework assignment. Looking at online solutions from previous semesters or other students is forbidden, as is sharing of your solutions with others. Furthermore, students all have an affirmative duty to report possible cases of cheating or unauthorized communication to the course staff, immediately. Acknowledgement of and failure to report cheating implicates the bystander since this is academic misconduct. Cheating hurts us all and engineering ethics requires us to point out wrongdoing when we are aware of it.

Submit cheating incident reports via this [form](#).

We expect that most students can distinguish between helping other students and cheating. Explaining the meaning of a question, discussing a way of approaching a solution, or collaboratively exploring how to solve a problem within your group is an interaction that we encourage strongly. But you should write your homework solution strictly by yourself so that your hands and eyes can help you internalize the subject matter. You should acknowledge everyone whom you have worked with, or who has given you any significant ideas about the homework. This is good scholarly conduct.

Don't Be Afraid to Ask for Help

Are you struggling? Please come talk with us! The earlier we learn about your struggles, the more likely it is that we can help you. Waiting until right before an exam or the last few weeks of the semester to let us know about your problems is not an effective strategy - the later it is, the less we will be able to help you.

Even if you are convinced that you are the only person in the class who is struggling, please overcome any feelings of embarrassment or guilt, and come ask for help as soon as you need it -- we can almost guarantee you're not the only person who feels this way. Don't hesitate to ask us for help -- we really do care that you thrive!

Advice

The following tips are offered based on our experience.

Do the homeworks! The homeworks are explicitly designed to help you to learn the material as you go along. There is usually a strong correlation between homework scores and final grades in the class.

Keep up with lectures! Discussion sections, labs and homeworks all touch on portions of what we discuss in lecture. **Students do much better if they stay on track with the course.** That will also help you keep the pace with your homework and study group.

Take part in discussion sections! Discussion sections are not auxiliary lectures. They are an opportunity for interactive learning. The success of a discussion section depends largely on the willingness of students to participate actively in it. As with office hours, the better prepared you are for the discussion, the more you are likely to benefit from it.

Please come to office hours! We love to talk to you and do a deep dive to help you understand the material better.

Form study groups! As stated above, you are encouraged to form small groups (two to four people) to work together on homeworks and on understanding the class material on a regular basis. In addition to being fun, this can save you a lot of time by generating ideas quickly and preventing you from getting hung up on some point or other. Of course, it is your responsibility to ensure that you contribute actively to the group; passive listening will likely not help you much. And recall the caveat above that you must write up your solutions on your own. We advise you strongly to spend some time on your own thinking about each problem before you meet with your study partners; this way, you will be in a position to compare ideas with your partners, and it will get you in practice for the exams. **Make sure you work through all problems yourself**, and that your final write-up is your own. Some groups try to split up the problems ("you do Problem 1, I'll do Problem 2, then we'll swap notes"); not only is this a punishable violation of our collaboration policies, it also ensures you will learn a lot less from this course.