

LAST Name _____ FIRST Name _____

Lab Time _____

- **(10 Points)** Print your name and lab time in legible, block lettering above AND on the last page where the grading table appears.
- This exam should take up to 70 minutes to complete. You will be given at least 70 minutes, up to a maximum of 80 minutes, to work on the exam.
- **This exam is closed book.** Collaboration is not permitted. You may not use or access, or cause to be used or accessed, any reference in print or electronic form at any time during the exam, except two double-sided 8.5" × 11" sheets of handwritten notes having no appendage. Computing, communication, and other electronic devices (except dedicated timekeepers) must be turned off. Noncompliance with these or other instructions from the teaching staff—*including, for example, commencing work prematurely or continuing beyond the announced stop time*—is a serious violation of the Code of Student Conduct. Scratch paper will be provided to you; ask for more if you run out. You may not use your own scratch paper.
- **The exam printout consists of pages numbered 1 through 10.** When you are prompted by the teaching staff to begin work, verify that your copy of the exam is free of printing anomalies and contains all of the ten numbered pages. If you find a defect in your copy, notify the staff immediately.
- Please write neatly and legibly, because *if we can't read it, we can't grade it.*
- For each problem, limit your work to the space provided specifically for that problem. *No other work will be considered in grading your exam. No exceptions.*
- Unless explicitly waived by the specific wording of a problem, you must explain your responses (and reasoning) succinctly, but clearly and convincingly.
- We hope you do a *fantastic* job on this exam.

MT2.1 (40 Points) The block diagram below shows an architecture for implementing an amplitude modulator using signal adders and square-law devices (SLDs). The real-valued signals x_1 and x_2 are the inputs to the amplitude modulator and y is its output.

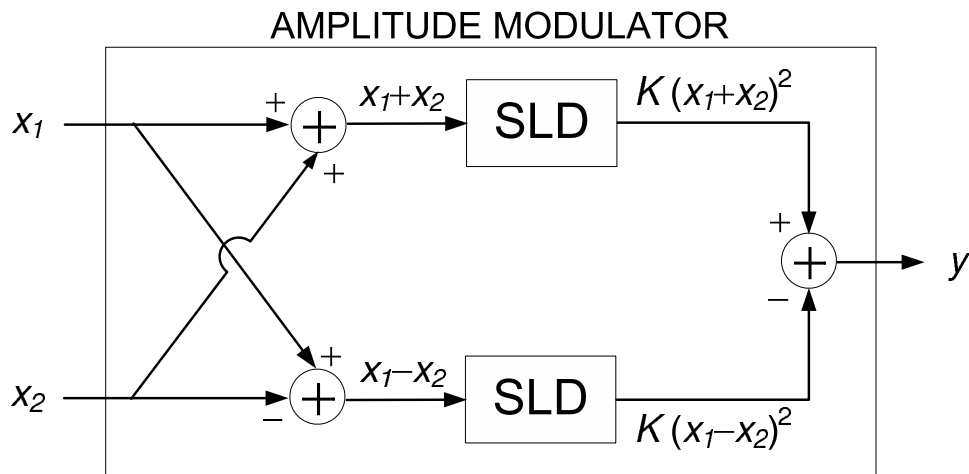

Each square-law device is characterized by the following parabolic input-output graph, where x_{SLD} denotes the input to the SLD and y_{SLD} the output. The parameter K is a positive constant.

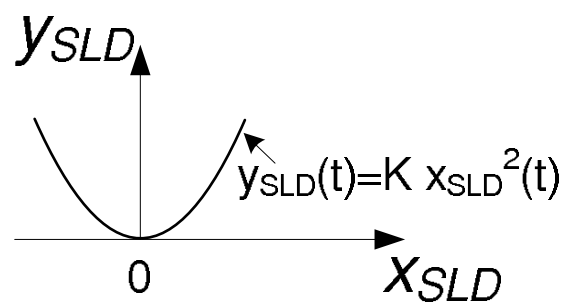

Formulas and Facts of Potential Use or Interest:

$$\cos(\alpha + \beta) = \cos \alpha \cos \beta - \sin \alpha \sin \beta$$

$$\cos \alpha \cos \beta = \frac{1}{2} [\cos(\alpha + \beta) + \cos(\alpha - \beta)]$$

(a) Show that if $K = \frac{1}{4}$, the amplitude modulator output y is characterized by

$$y(t) = x_1(t) x_2(t), \quad \forall t \in \mathbb{R}.$$

(b) Select the *strongest correct* assertion from the following choices. Explain your reasoning succinctly, but clearly and convincingly.

- (I) The amplitude modulator above *must* be memoryless.
- (II) The amplitude modulator above *can* be memoryless.
- (III) The amplitude modulator above *cannot* be memoryless.

(c) Select the *strongest correct* assertion from the following choices. Explain your reasoning succinctly, but clearly and convincingly.

- (I) The amplitude modulator above *must* be causal.
- (II) The amplitude modulator above *can* be causal.
- (III) The amplitude modulator above *cannot* be causal.

(d) Select the *strongest correct* assertion from the following choices. Explain your reasoning succinctly, but clearly and convincingly.

- (I) The amplitude modulator above *must* be time invariant.
- (II) The amplitude modulator above *can* be time invariant.
- (III) The amplitude modulator above *cannot* be time invariant.

(e) Select the *strongest correct* assertion from the following choices. Explain your reasoning succinctly, but clearly and convincingly.

(I) The amplitude modulator above *must* be linear.

(II) The amplitude modulator above *can* be linear.

(III) The amplitude modulator above *cannot* be linear.

(f) Suppose the input signals x_1 and x_2 are sinusoids characterized by instantaneous values

$$x_1(t) = \cos(\omega_1 t) \quad \text{and} \quad x_2(t) = \cos(\omega_2 t), \quad \forall t,$$

where $0 < \omega_1 < \frac{\omega_2}{2}$. For simplicity, assume $K = \frac{1}{4}$.

(i) Provide a well-labeled sketch of the spectrum of the output signal y . Be sure to explain your reasoning succinctly, but clearly and convincingly.

(ii) Prove that the output signal y is periodic if, and only if, the ratio of the frequencies ω_1 and ω_2 is a rational number, i.e.,

$$\frac{\omega_1}{\omega_2} \in \mathbb{Q}.$$

MT2.2 (30 Points) The following diagram shows a combination lock.

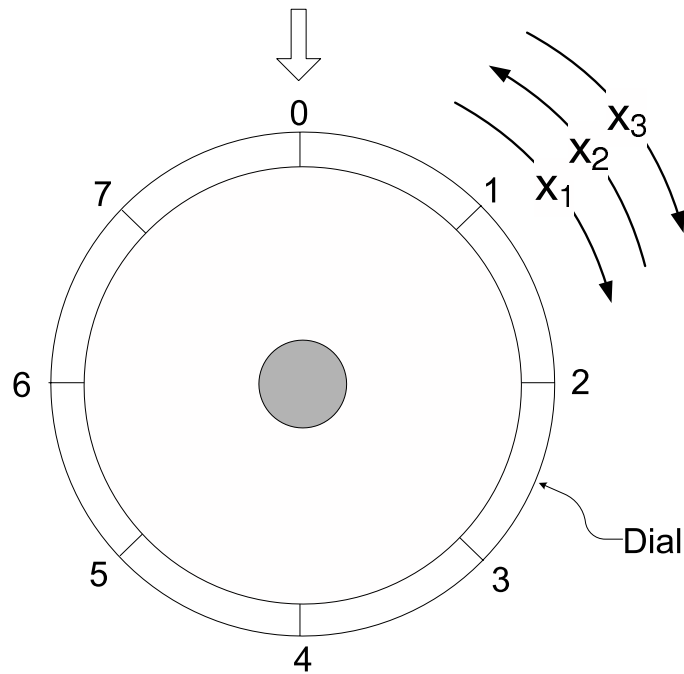

The lock can be opened only if an ordered sequence of *three* numbers—selected in strict adherence to the following steps—matches the lock’s unique “combination”:

- Step I.** Turn the dial clockwise two or more whole turns, and stop at the first number of the combination.
- Step II.** Turn the dial counter-clockwise one whole turn past the number in Step 1, and stop at the second number of the combination.
- Step III.** Turn the dial clockwise and stop at the third number of the combination.

The combination for this lock (i.e., the only sequence of numbers that opens it) is (1, 3, 5). This means that to open the lock, a user must stop at 1 at the end of Step I; stop at 3 at the end of Step II; and stop at 5 at the end of Step III.

The thick vertical arrow at the top of the diagram is fixed, and it marks the number selected by the user at the end of every step.

The combination lock can be thought of as a mechanical system, where the "input signal" is the sequence of three numbers

$$x = (x_1, x_2, x_3) \in \{0, 1, 2, \dots, 7\}^3$$

selected by the user who rotates the dial according to the steps and rules described above; needless to say, the sequence of numbers selected by the user may or may not match the lock's combination (1, 3, 5).

The "output" signal $y = (y_1, y_2, y_3)$ shows the the sequence of *states* of the lock corresponding to the input sequence (x_1, x_2, x_3) . The state of the lock upon completion of each step described above is either *Locked* (L) or *Unlocked* (U).

By way of example, if the input signal is (1, 2, 4), the corresponding output signal is (L, L, L), which means that the user has failed to open the lock. If, on the other hand, the user applies the input signal (1, 3, 5), then the output signal will be (L, L, U), which means that the user has succeeded in opening the lock.

We can describe the combination lock by the function

$$\begin{aligned} \text{CombinationLock} : \quad & \{0, 1, 2, \dots, 7\}^3 \rightarrow S \\ y &= \begin{cases} (L, L, U) & \text{if } x = (1, 3, 5) \\ (L, L, L) & \text{otherwise.} \end{cases} \end{aligned}$$

The set S is something you will determine below.

In tackling this problem, consider only dial rotations that conform to the rules described above.

- (a) Determine the size of the input signal space; that is, determine how many valid input signals (x_1, x_2, x_3) exist.

Also, determine S so that the description of the system is an *onto* function. What is the size of S?

(b) Select the *strongest correct* assertion from the following choices. Explain your reasoning succinctly, but clearly and convincingly.

- (I) The combination lock *must* be a memoryless system.
- (II) The combination lock *can* be a memoryless system.
- (III) The combination lock *cannot* be a memoryless system.

(c) Select the *strongest correct* assertion from the following choices. Explain your reasoning succinctly, but clearly and convincingly.

- (I) The combination lock *must* be a causal system.
- (II) The combination lock *can* be a causal system.
- (III) The combination lock *cannot* be a causal system.

MT2.3 (35 Points) Consider an ideal interlocking pair of rotating mechanical gears shown in the figure below. By ideal we mean that you can ignore friction and slippage between the gears.

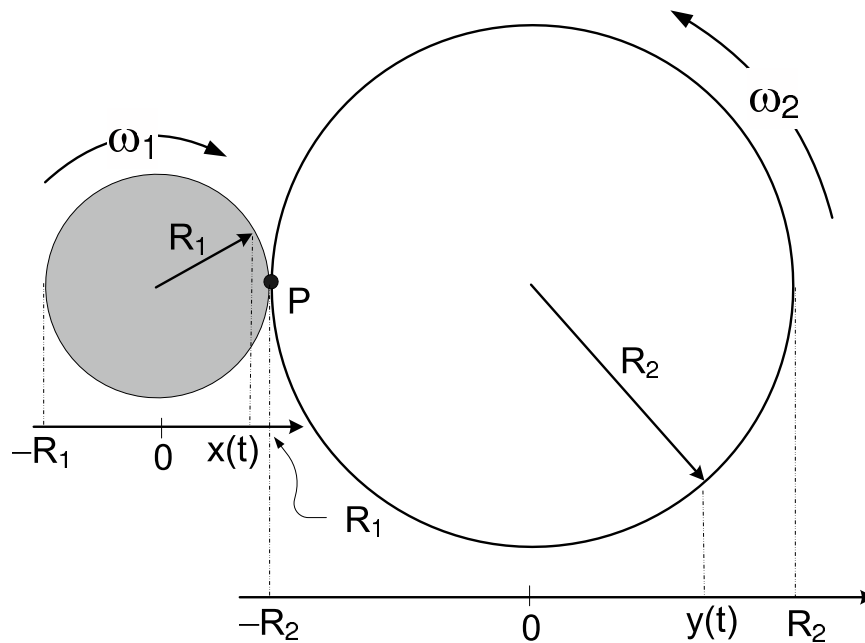

The respective radii of the two gears are shown in the diagram, and are related according to $0 < R_1 < R_2$.

The smaller gear is the driver. The projection x can be thought of as the input signal to this mechanical system.

The larger gear responds to the rotation of the smaller gear. Accordingly, we can think of the projection y as the output signal of this mechanical system.

The smaller gear is shown rotating clockwise with angular velocity ω_1 radians per second; the larger gear rotates in the opposite direction. At the contact point P where the two gears touch, they must have equal tangential velocities. Therefore,

$$\omega_1 R_1 = \omega_2 R_2.$$

An input-output depiction of the mechanical system is shown below.

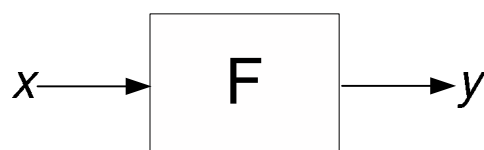

The instantaneous values $x(t)$ and $y(t)$ of the input and output signals are shown in the figure and are described by

$$x(t) = R_1 \cos(\omega_1 t) \quad \text{and} \quad y(t) = R_2 \cos(\omega_2 t), \quad \forall t.$$

In answering the following questions, assume $\omega_1 = \pi/3$ and $R_1 = R_2/2$.

(a) Select the *strongest correct* assertion from the list below.

- (i) F must be a time-invariant system.
- (ii) F can be a time-invariant system.
- (iii) F cannot be a time-invariant system.

(b) Select the *strongest correct* assertion from the list below.

- (i) F must be a memoryless system.
- (ii) F can be a memoryless system.
- (iii) F cannot be a memoryless system.

(c) Select the *strongest correct* assertion from the list below.

- (i) F must be a causal system.
- (ii) F can be a causal system.
- (iii) F cannot be a causal system.

LAST Name _____ FIRST Name _____

Lab Time _____

Problem Name	Points	Your Score
1	40	
2	30	
3	35	
Total	115	