

PRINT your student ID: _____

Extra page for scratchwork.

If you want any work on this page to be graded, please tell us exactly where to look in the problem's solution area.

PRINT your student ID: _____

5. 16A (Taylor's Version) (22 points)

After attending Taylor Swift's Eras Tour, you are excited to make your own LED-based synchronized wristbands. For the course of this problem, we will model our LEDs as resistors.

(a) (2 points) Examine the following layout of LEDs in your first bracelet model, shown in Figure 5.1:

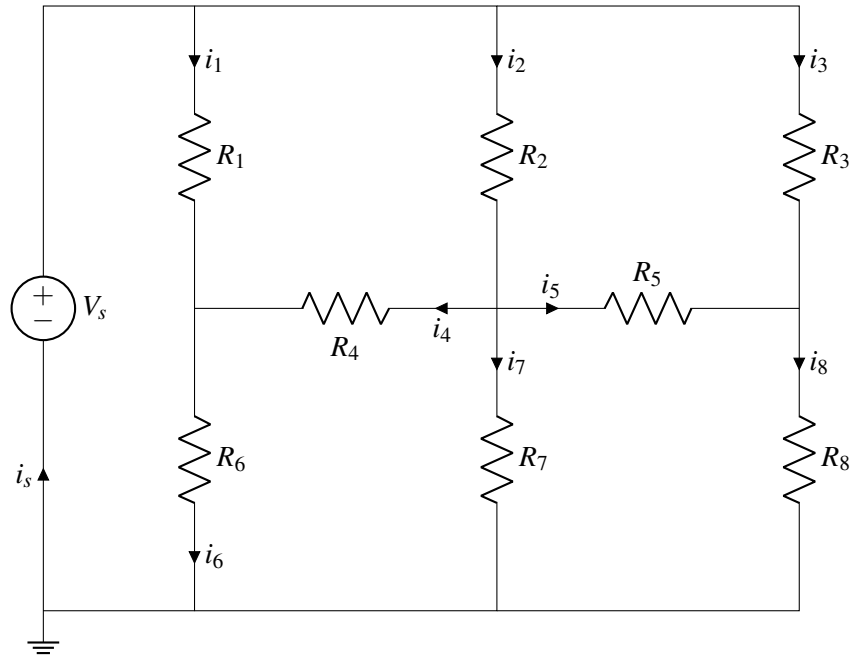
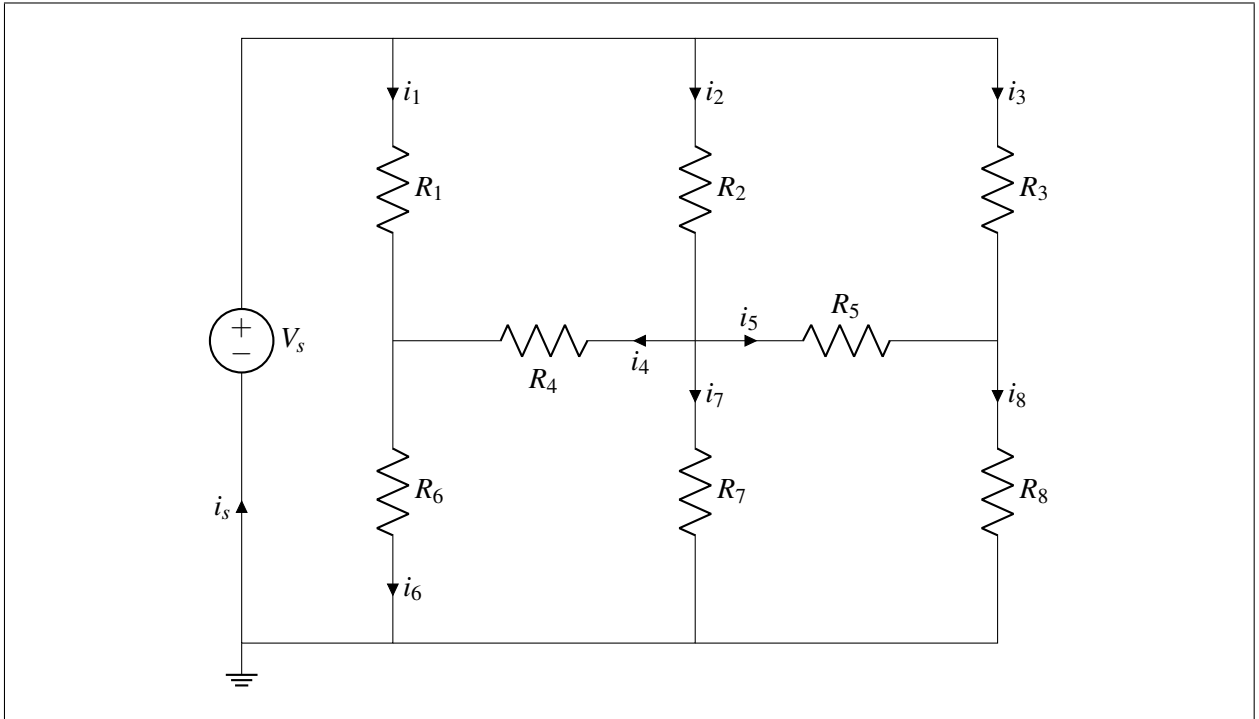

Figure 5.1: Initial Bracelet Model

How many nodes are there in this circuit?

PRINT your student ID: _____

- (b) (4 points) **Label the element voltages on V_s , R_4 , R_5 , and R_6** in the circuit below (identical to Figure 5.1) such that the current flow abides by **passive sign convention**.



- (c) (3 points) Once again, consider the circuit in Figure 5.1 (also repeated above in part (b)). Let $V_s = 12\text{V}$. **Write Kirchhoff's Current Law (KCL) equations for all nodes with *unknown* node potentials.**

PRINT your student ID: _____

- (d) (4 points) To create a light pattern, we want to turn off the LEDs corresponding to R_4 and R_5 in the circuit in Figure 5.1, repeated below. An LED is off if there is zero current flowing through it. The values of R_4 and R_5 are fixed at $10\ \Omega$.

Select values for $R_1, R_2, R_3, R_6, R_7,$ and R_8 such that the current flowing through R_4 and R_5 is zero. Due to component availability, these resistors can be **either $1\ \Omega$ or $10\ \Omega$.** **List the values, with units, on the appropriate lines. Use the box to justify your answer.**

R_1 : _____

R_2 : _____

R_3 : _____

R_6 : _____

R_7 : _____

R_8 : _____

Circuit reproduced for your reference.

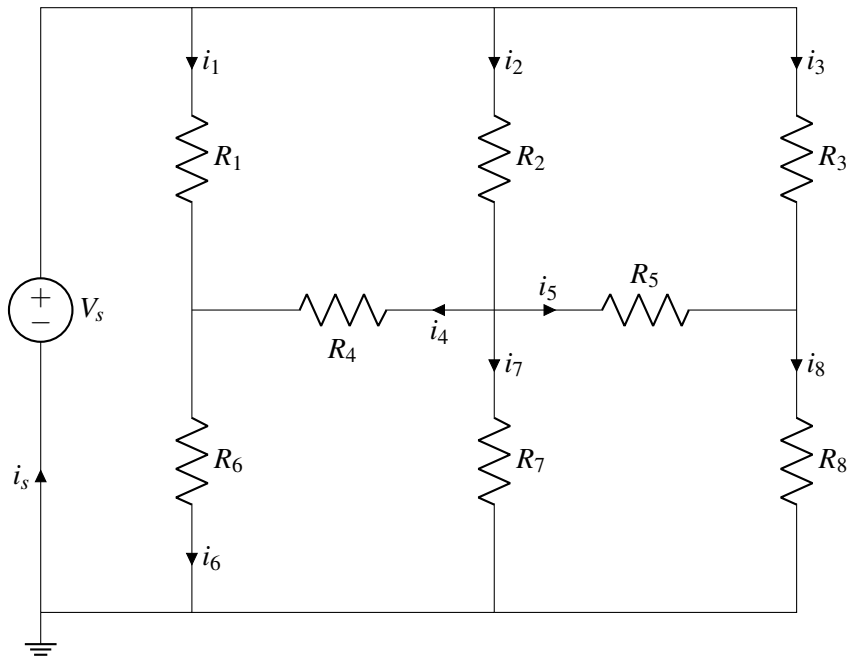
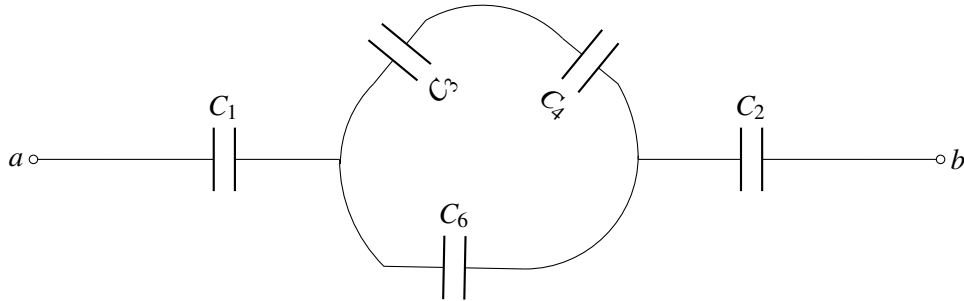

Figure 5.1

PRINT your student ID: _____

- (e) (4 points) Kanav suggests a different LED bracelet that uses a network of capacitors to store and release energy for the lights, as shown below:



Write the expression for the equivalent capacitance between nodes a and b . You may use the \parallel operator in your answer. You do not need to simplify or justify your expression.

PRINT your student ID: _____

- (f) (5 points) Manooshree is at the Taylor Swift concert, and is wearing a different bracelet, as shown in Figure 5.2. It has six LEDs (modeled as resistors) — two red, two yellow, and two blue. You want to identify which color is dissipating the most power (i.e. shining the brightest). Each color corresponds to a different Era that Taylor is singing, as in the following table. **Identify which color (pair of resistors) is dissipating the most power**, and which Era this corresponds to. **Justify your answer.**

Era	Brightest Color
Fearless	Yellow
Red	Red
1989	Blue

Note: You can rigorously justify which color is dissipating the most power without explicitly calculating all the powers, though you may calculate them if you prefer.

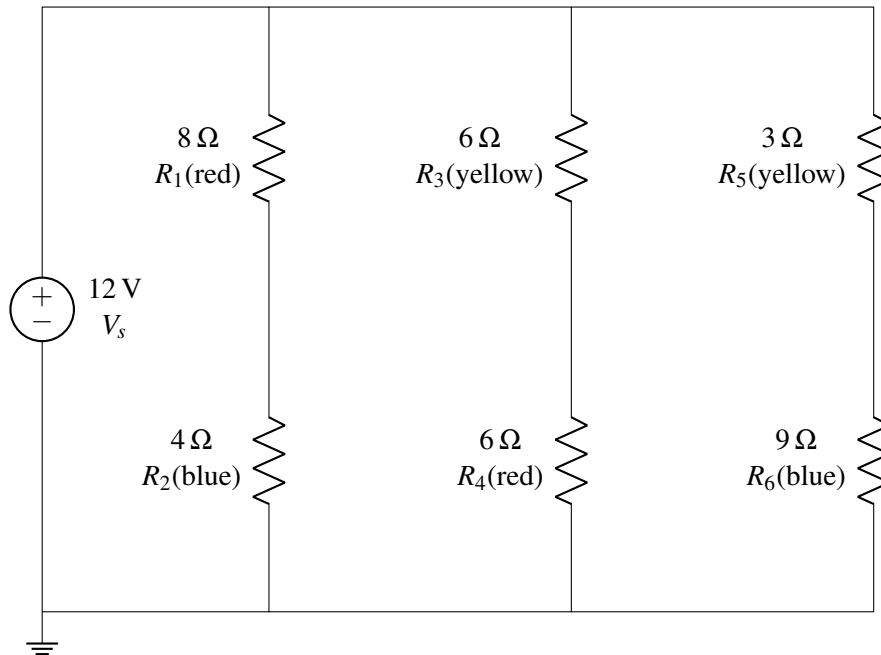

Figure 5.2: Manooshree's Bracelet Model

PRINT your student ID: _____

Extra page for scratchwork.

If you want any work on this page to be graded, please tell us exactly where to look in the problem's solution area.

PRINT your student ID: _____

6. Anti-Hero (2 points)

Is the circuit below in negative feedback? Select your answer by completely filling in the appropriate circle. No justification is required.

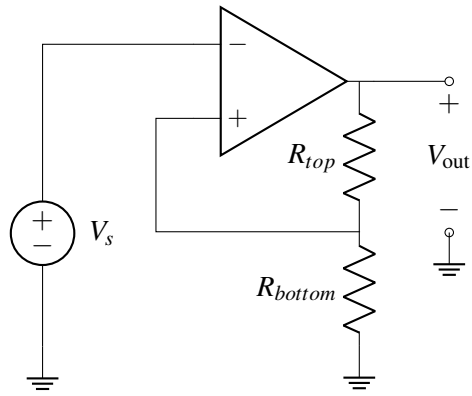

In negative feedback

Not in negative feedback

PRINT your student ID: _____

7. Mastermind (11 points)

Sunash is studying neurons. The outer and inner layers of the neuron's cell membrane can be modeled as resistors with resistances R_2 and R_3 , respectively. Current is driven by an ion-pump protein that can be modeled as a voltage source V_s with internal resistance R_1 . The full model for the neuron cell membrane is shown below.

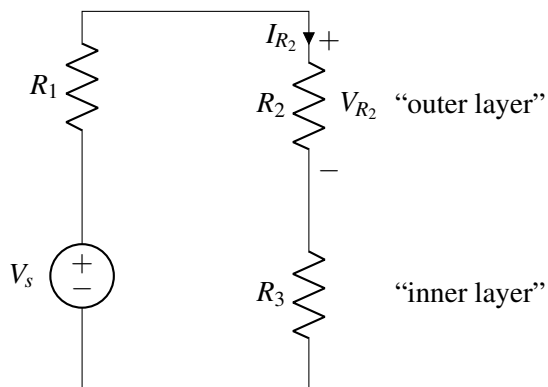

Figure 7.1

Sunash's primary interest is in the protein behavior in the outer layer, so he aims to measure the voltage drop across this layer, V_{R_2} .

- (a) (4 points) **Find an expression for V_{R_2} in terms of V_s and the resistances R_1 , R_2 , and R_3 , in Figure 7.1.**

PRINT your student ID: _____
 Circuit repeated for your reference.

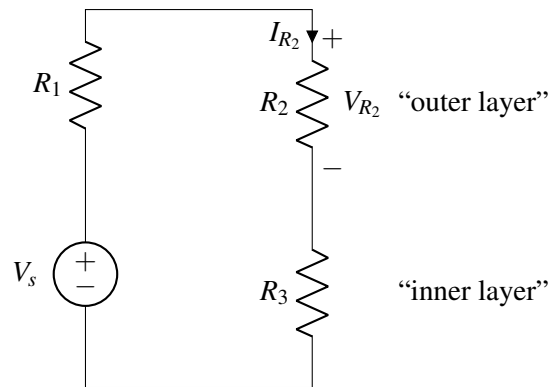
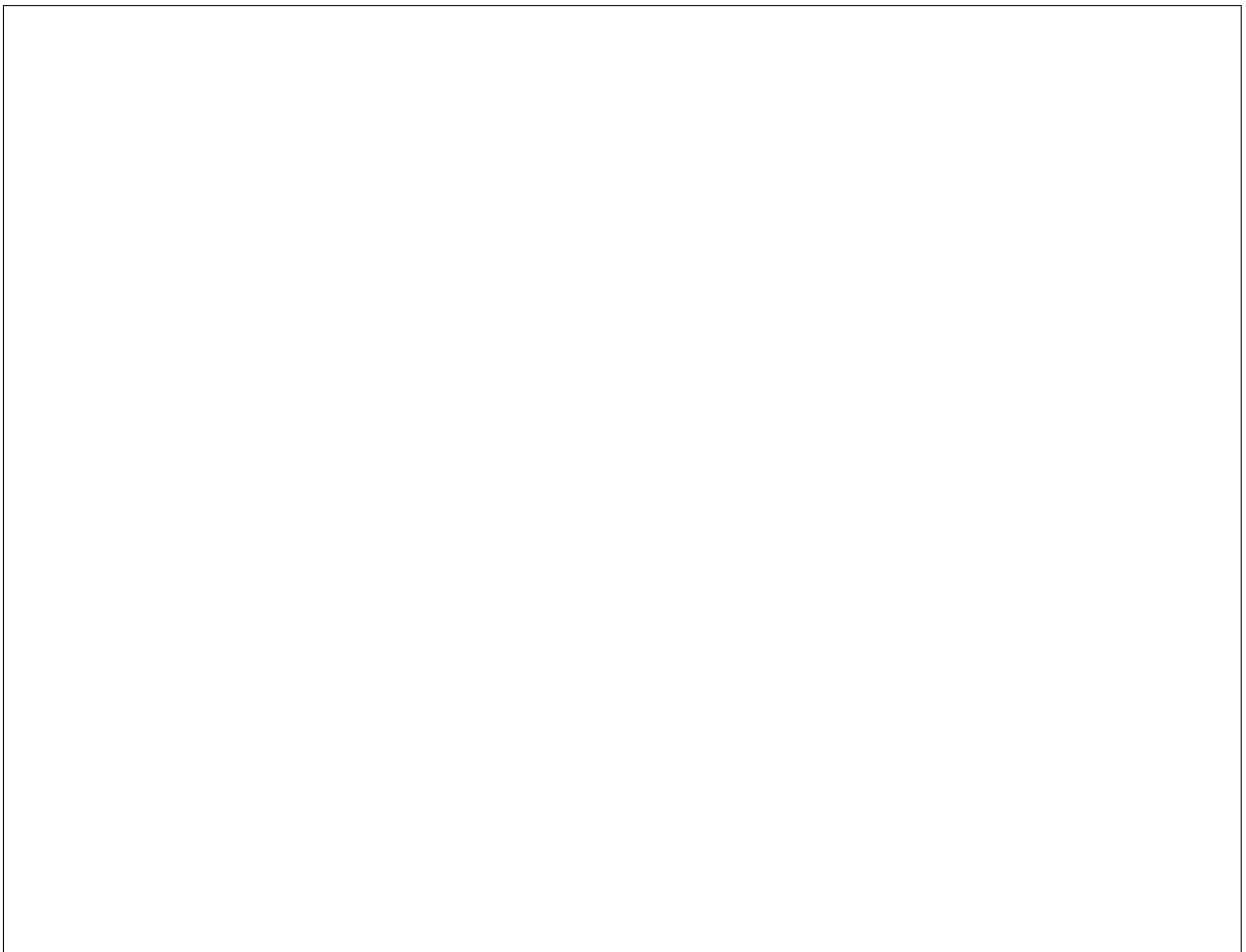

Figure 7.1

- (b) (3 points) We wish to measure V_{R_2} using an ideal voltmeter and I_{R_2} (the current through R_2) using an ideal ammeter. **Redraw the circuit in Figure 7.1 with the ideal voltmeter and ammeter correctly connected.**



PRINT your student ID: _____

(c) (4 points) Sunash discovers he can modify how the neuron behaves. He can add up to five parallel paths for current, each with a **finite** resistance R_C , as shown in Figure 9.2.

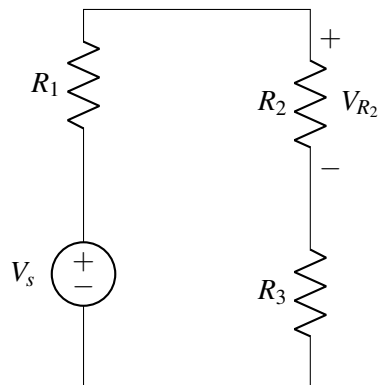

Figure 7.1

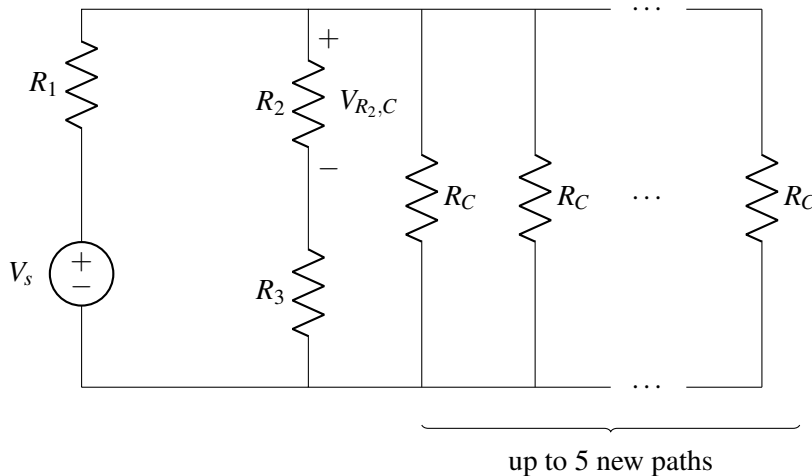

Figure 7.2

Which choice below **most accurately** describes the relationship between V_{R_2} , the voltage drop across R_2 in the original circuit of Figure 7.1, and $V_{R_2,C}$, the voltage drop across R_2 in Figure 9.2 when exactly five parallel paths are added?

- $V_{R_2} > V_{R_2,C}$
- $V_{R_2} < V_{R_2,C}$
- $V_{R_2} = V_{R_2,C}$
- $V_{R_2} \geq V_{R_2,C}$
- $V_{R_2} \leq V_{R_2,C}$

PRINT your student ID: _____

8. Getaway Car (8 Points)

You would like to design a sensor that detects if a driver is touching the steering wheel, as part of an autonomous driving system. Anastasia offers to help you with the warning system design.

(a) (3 points) You first need to design a new parallel plate capacitor. You are given the following requirements and information:

- The capacitor must have a total capacitance of $400\epsilon_0 \cdot 10^{-2} \cdot \text{m}$ (recall the units of ϵ_0 are F/m).
- The cross-sectional area of the plates is 10^{-3} m^2 .
- The dielectric (i.e. the material between the capacitor plates), has a permittivity 80 times that of vacuum (i.e. $80\epsilon_0$).

Finalize your design by **determining the distance between the plates of the capacitor in meters.**
Show your work.

PRINT your student ID: _____

- (b) (5 points) You are given the following waveform of voltage across your capacitor, V_C , in the touch and no-touch cases.

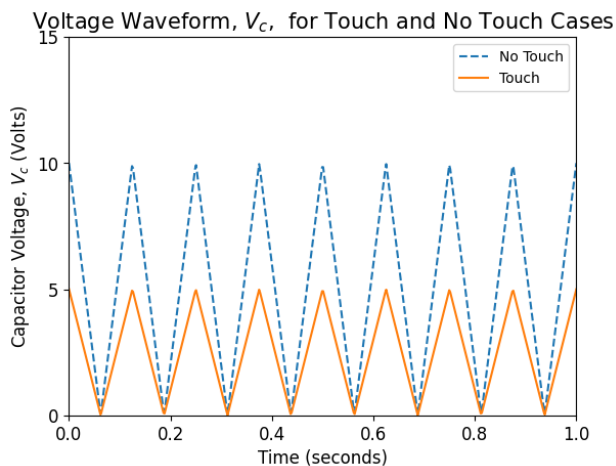
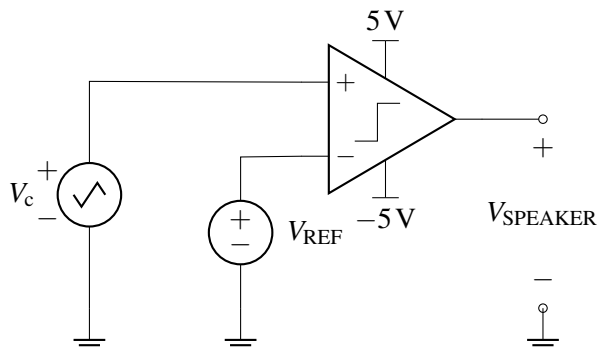

Figure 8.1: Voltage Waveform

You would like to use this voltage, V_C , and utilize it to beep a speaker (i.e. turn on and off repeatedly) when there is no touch. You discover this circuit schematic, but the value of V_{REF} is erased. The speaker turns on when the voltage across it, $V_{SPEAKER}$, is +5 Volts.



Select an appropriate value, with units, for V_{REF} such that the speaker beeps on and off when there is no touch, and is quiet when there is a touch. Justify your answer.

PRINT your student ID: _____

9. Sparks Fly (22 points)

- (a) (4 points) Ryan is trying to use old circuits and devices from a junk pile to light up a lightbulb. He finds the following device in the junk pile.

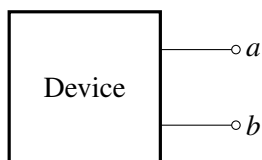

The device has the following Thévenin equivalent circuit:

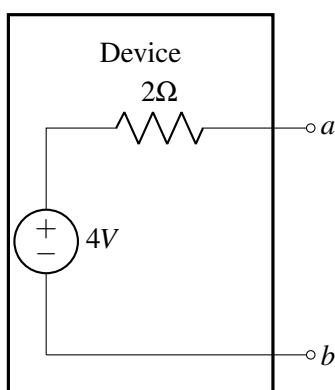

Plot the I-V curve of this device on the grid lines below.

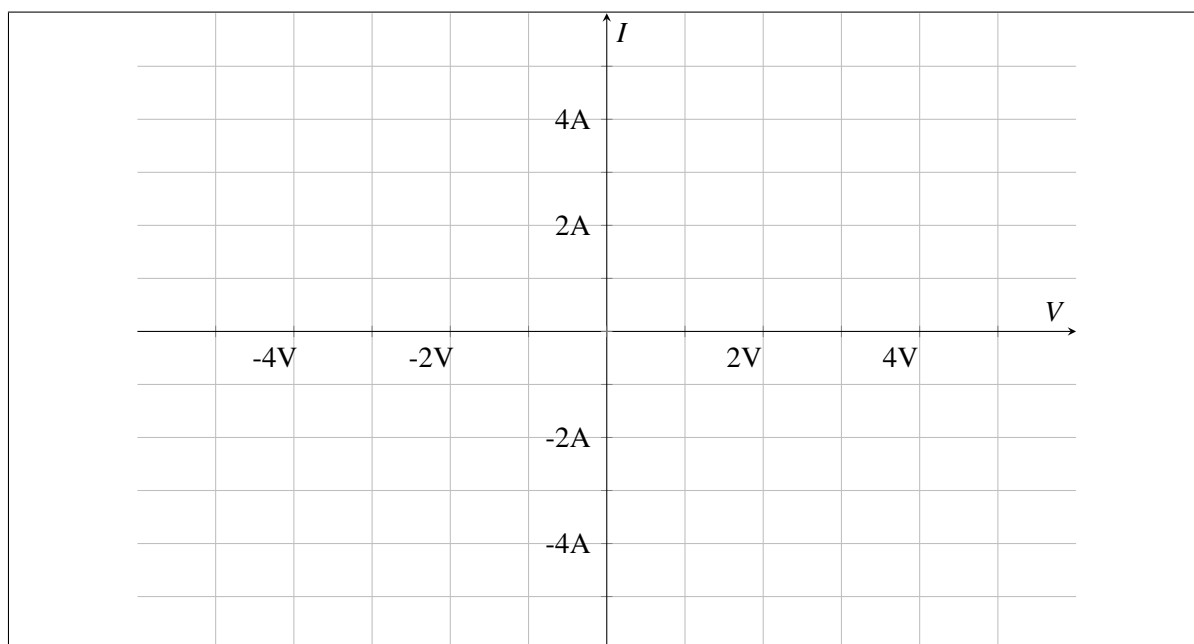

PRINT your student ID: _____

- (b) (6 points) Suppose Ryan instead finds the circuit shown in Figure 9.1 in the junk pile. To simplify the analysis of this circuit, Ryan finds out that the circuit has a Thévenin equivalent circuit from the perspective of nodes a and b , shown in Figure 9.2:

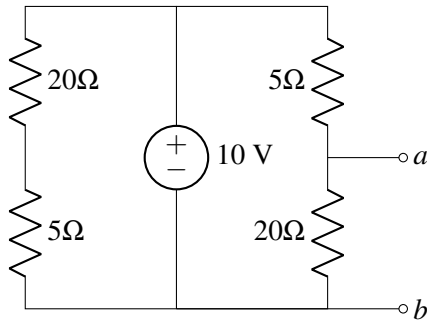

Figure 9.1

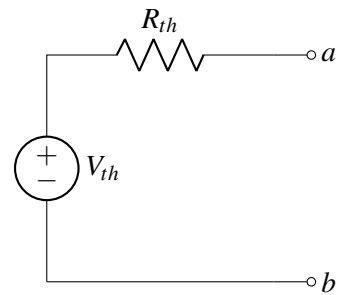
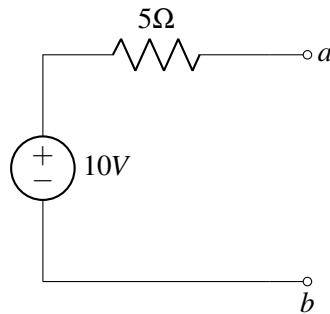

Figure 9.2

Find V_{th} and R_{th} . Show your work.

PRINT your student ID: _____

(c) (7 points) Suppose that Ryan finds a different circuit that has the following Thévenin equivalent circuit:



Ryan wants to light up a lightbulb with load $R_L = 10\Omega$. However, the light bulb is very sensitive and needs **exactly** $5V$ across it in order to function. After searching around, he finds a variable resistor whose resistance, R_{extra} , can be adjusted to any resistance.

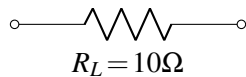

Design a circuit using R_L , R_{extra} , and the circuit above so that the voltage across R_L is $5V$. Specify what the value of R_{extra} is if you decide to use it. **Draw the circuit you design in the space below. Justify your answer.**

PRINT your student ID: _____

(d) (5 points) Ryan now connects up two circuits he finds to get the following circuit:

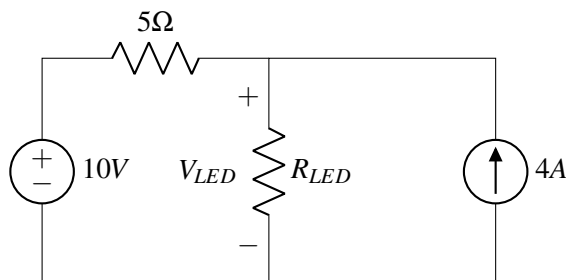

If $R_{LED} = 5\Omega$, what is V_{LED} , the voltage across R_{LED} ? Show your work.

PRINT your student ID: _____

10. London Boy (16 points)

Taylor Swift has hired you to design her personal electric scooter using your new circuits knowledge from EECS16A. You must build a circuit to produce a pulse-width modulation (PWM) signal used to control the motor's speed. *Note: you do not need to know how PWM signals work for this problem.*

- (a) (5 points) You are given a circuit that contains a time-varying current source $I_s(t)$ connected to a capacitor, with capacitance C , as shown below:

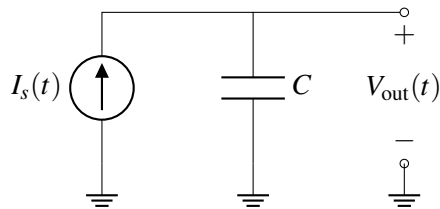

You are told that $C = 1 \mu\text{F}$ and $I_s(t)$ outputs a square wave shown below:

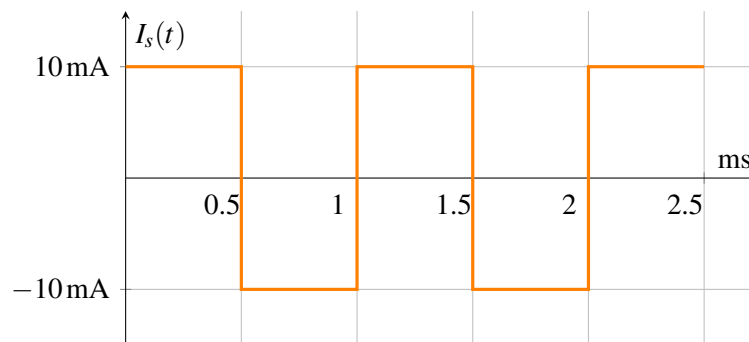

Assuming $V_{\text{out}}(0) = 0\text{V}$, plot $V_{\text{out}}(t)$ from $t = 0\text{ms}$ to $t = 2.5\text{ms}$ in the space provided below. Clearly label the minimum and maximum values.

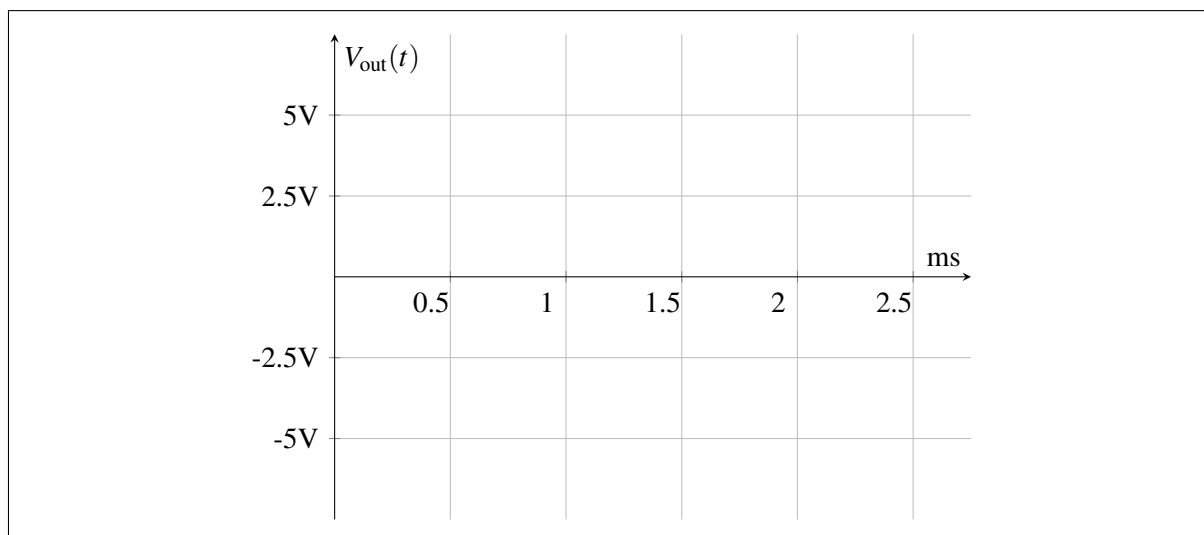

PRINT your student ID: _____

- (b) (4 points) In order to create the desired PWM signal $V_{\text{PWM}}(t)$, you connect $V_{\text{out}}(t)$ to the comparator circuit below.

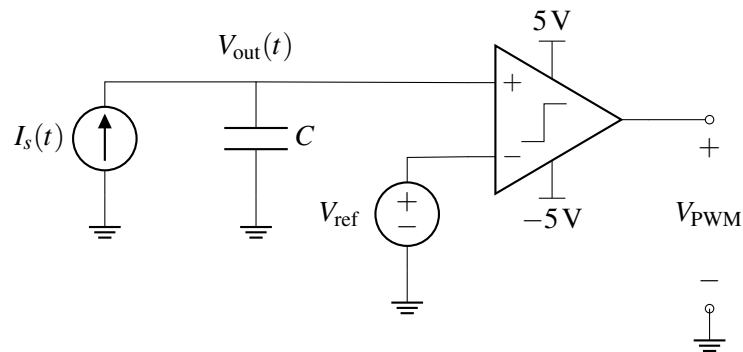

For this part, assume $V_{\text{out}}(t)$ is the following triangle wave:

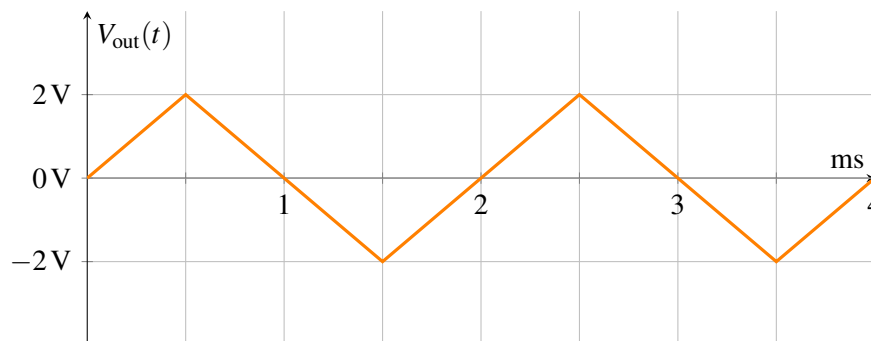

$V_{\text{PWM}}(t)$ will also be a periodic signal that switches between -5 V and $+5\text{ V}$. **Find the value of V_{ref} such that $V_{\text{PWM}}(t) = +5\text{ V}$ for 50% of the time (also called a 50% duty cycle). Justify your answer.**

PRINT your student ID: _____

Your scooter's microcontroller outputs two digital control voltages V_0, V_1 to control your scooter's speed. You come across the op-amp circuit below and think it may be helpful but you are unsure of exactly how it operates. You may assume that $V_{DD} = -V_{SS}$ for this op-amp, and that it is ideal and in negative feedback.

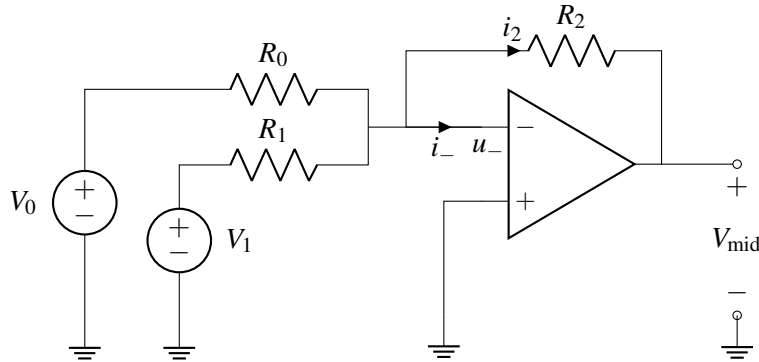

(c) (2 points) **What is the voltage at the negative terminal of the op-amp, u_- ?**

(d) (2 points) **What is the current into the negative terminal of the op-amp, i_- ?**

(e) (3 points) **What is the current i_2 through the upper resistor (R_2) in terms of V_0, V_1, R_0, R_1 , and R_2 ?** Note that you may not need to use all of these quantities in your expression. Show your work and justify your answer.

Hint: Use superposition and KCL at the u_- node.

PRINT your student ID: _____

Extra page for scratchwork.

If you want any work on this page to be graded, please tell us exactly where to look in the problem's solution area.

PRINT your student ID: _____

Extra page for scratchwork.

If you want any work on this page to be graded, please tell us exactly where to look in the problem's solution area.

PRINT your student ID: _____

Extra page for scratchwork.

If you want any work on this page to be graded, please tell us exactly where to look in the problem's solution area.

PRINT your student ID: _____

Doodle page!

Draw us something if you want or give us suggestions, compliments, or complaints.
You can also use this page to report anything suspicious that you might have noticed.

Read the following instructions before the exam.

There are 10 problems of varying numbers of points. Not all subparts of a question are related to each other. You have 80 minutes for the exam. The problems are of varying difficulty, so pace yourself accordingly and avoid spending too much time on any one question until you have gotten all of the other points you can.

There are 26 pages on the exam, so there should be 13 sheets of paper in the exam. The exam is printed double-sided. Do not forget the problems on the back sides of the pages! Notify a proctor immediately if a page is missing. **Do not tear out or remove any of the pages. Do not remove the exam from the exam room.**

No collaboration is allowed, and do not attempt to cheat in any way. Cheating will not be tolerated.

Write your student ID on each page before time is called. If a page is found without a student ID, we are not responsible for identifying the student who wrote that page.

You may consult TWO handwritten $8.5'' \times 11''$ note sheets (front and back). No phones, calculators, tablets, computers, other electronic devices, or scratch paper are allowed.

Please write your answers legibly in the boxed spaces provided on the exam. The space provided should be adequate. **If you still run out of space, please use a blank page and clearly tell us in the original problem space where to look for your solution.**

Show all of your work in order to receive full credit. Partial credit will be given for substantial progress on each problem. **Do not forget units** when relevant.

If you need to use the restroom during the exam, bring your student ID card, your phone, and your exam to a proctor. You can collect them once you return from the restrooms.

Our advice to you: if you can't solve the problem, state and solve a simpler one that captures at least some of its essence. You might get some partial credit, and more importantly, you will perhaps find yourself on a path to the solution.

Good luck!

Do not turn this page until the proctor tells you to do so.