

FIRST Name _____ LAST Name _____

Discussion Time: _____ SID (All Digits): _____

- **(20 Points)** Print your *official* name (not your e-mail address) and *all* digits of your student ID number legibly, and indicate your lab time, on *every* page.
- This exam should take up to 100 minutes to complete. However, you may use up to a maximum of 110 minutes *in one sitting*, to work on the exam.
- **This exam is closed book.** Collaboration is not permitted. You may not use or access, or cause to be used or accessed, any reference in print or electronic form at any time during the exam, except one double-sided 8.5" × 11" sheet of handwritten, original notes having no appendage. Computing, communication, and other electronic devices (except dedicated timekeepers) must be turned off. Noncompliance with these or other instructions from the teaching staff—including, for example, *commencing work prematurely or continuing beyond the announced stop time*—is a serious violation of the Code of Student Conduct. Scratch paper will be provided to you; ask for more if you run out. You may not use your own scratch paper.
- We will provide you with scratch paper. Do not use your own.
- **The exam printout consists of pages numbered 1 through 10.** When you are prompted by the teaching staff to begin work, verify that your copy of the exam is free of printing anomalies and contains all of the ten numbered pages. If you find a defect in your copy, notify the staff immediately.
- Please write neatly and legibly, because *if we can't read it, we can't evaluate it*.
- For each problem, limit your work to the space provided specifically for that problem. *No other work will be considered. No exceptions.*
- Unless explicitly waived by the specific wording of a problem, you must explain your responses (and reasoning) succinctly, but clearly and convincingly.
- We hope you do a *fantastic* job on this exam.

FIRST Name _____ LAST Name _____

Discussion Time: _____

SID (All Digits): _____

MT1.1 (50 Points) Consider a *linear* discrete-time system H , about which we know—for every integer k —what the figure below depicts.

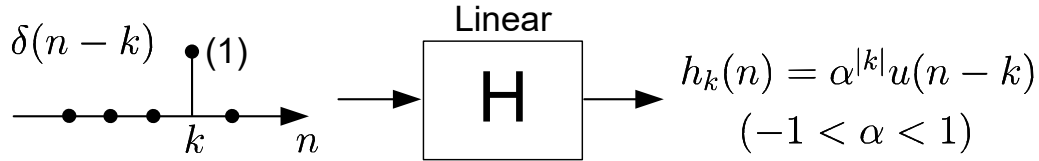

In this problem, it may or may not be useful for you to know that

$$\sum_{\ell=0}^{\infty} \alpha^{\ell} = \frac{1}{1-\alpha} \quad \text{if } |\alpha| < 1 \quad \text{and} \quad \sum_{\ell=M}^N \alpha^{\ell} = \begin{cases} \frac{\alpha^{N+1} - \alpha^M}{\alpha - 1} & \text{if } \alpha \neq 1 \\ N - M + 1 & \text{if } \alpha = 1. \end{cases}$$

$$\left| \sum_{k=1}^N a_k \right| \leq \sum_{k=1}^N |a_k| \quad \text{and} \quad \left| \sum_{k=1}^{\infty} a_k \right| \leq \sum_{k=1}^{\infty} |a_k|, \quad \text{if } \sum_{k=1}^{\infty} |a_k| < \infty.$$

(a) (10 Points) Show that the output y , in response to a more general input x , is

$$\forall n \in \mathbb{Z}, \quad y(n) = \sum_{k=-\infty}^{+\infty} x(k) h_k(n).$$

(b) (10 Points) We apply the unit step as the input— $x(n) = u(n)$. Derive a reasonably-simple, *closed-form* expression (no summations) for the output $y(n)$.

FIRST Name _____ LAST Name _____

Discussion Section Time: _____ SID (All Digits): _____

(c) (10 Points) Select the strongest true assertion from the list below. Provide a succinct, yet clear and convincing explanation.

- (i) The system must be *time invariant*. (If so, give a proof.)
- (ii) The system could be *time invariant*, but does not have to be. (If so, specify every additional condition needed to make a determination.)
- (iii) The system cannot be *time invariant*. (If so, give a counterexample.)

(d) (10 Points) Select the strongest true assertion from the list below. Provide a succinct, yet clear and convincing explanation.

- (i) The system must be *causal*. (If so, give a proof.)
- (ii) The system could be *causal*, but does not have to be. (If so, specify every additional condition needed to make a determination.)
- (iii) The system cannot be *causal*. (If so, give a counterexample.)

FIRST Name _____ LAST Name _____

Discussion Section Time: _____ SID (All Digits): _____

- (e) (10 Points) We apply a bounded input x to the system, such that a positive quantity B_x exists for which $|x(n)| \leq B_x$ for all integers n . Show that the system is BIBO stable. Specifically, determine the smallest positive quantity B_y (based on the limited information given about the input x), such that $|y(n)| \leq B_y$ for all integers n . To receive full credit, you must derive a reasonably-simple, *closed-form* expression (no summations) for B_y , in terms of B_x and α .

FIRST Name _____ LAST Name _____

Discussion Time: _____

SID (All Digits): _____

MT1.2 (65 Points) Consider a causal, DT-LTI filter H whose input-output behavior is described by the linear, constant-coefficient difference equation (LCCDE)

$$y(n) = \alpha y(n-1) + (1-\alpha)x(n), \quad \text{for some } \alpha \in \mathbb{R},$$

where x is the input and y the output.

(a) (15 Points) Show that the impulse response of the filter is given by

$$\forall n \in \mathbb{Z}, \quad h(n) = (1-\alpha)\alpha^n u(n),$$

where u is the unit step. Also, determine a reasonably-simple expression for $h(n)$ in the special case $\alpha = 0$.

(b) (10 Points) Determine all the values of α for which the filter is BIBO stable.

FIRST Name _____ LAST Name _____

Discussion Section Time: _____ SID (All Digits): _____

(c) (10 Points) Suppose α is such that the filter is BIBO stable. Show that the frequency response of the filter is

$$\forall \omega \in \mathbb{R}, \quad H(\omega) = \frac{1 - \alpha}{1 - \alpha e^{-i\omega}}.$$

(d) (10 Points) We apply as input to the filter the signal $x(n) = 1 + (-1)^n$ for all integers n . Determine a reasonably-simple expression for the output $y(n)$.

FIRST Name _____ LAST Name _____

Discussion Section Time: _____ SID (All Digits): _____

- (e) (20 Points) On a single graph, and for $-\pi \leq \omega \leq +\pi$, provide a well-labeled plot of the $|H(\omega)|$ for each of $\alpha = 0$, $\alpha = 0.2$, $\alpha = 0.5$, and $\alpha = 0.8$.

FIRST Name _____ LAST Name _____

Discussion Time: _____

SID (All Digits): _____

MT1.3 (65 Points) A delay-adder-gain (DAG) block diagram implementation of a causal DT system H is shown below, where x and y are the scalar input and output, respectively. The state variables q_1 and q_2 have been labeled for your convenience. A state-space representation of the system is given generically by

$$\mathbf{q}(n + 1) = \mathbf{A} \mathbf{q}(n) + \mathbf{B}x(n) \quad (1)$$

$$y(n) = \mathbf{C} \mathbf{q}(n) + \mathbf{D}x(n), \quad (2)$$

where Eqns. (1) and (2) are the state-evolution and output equations, respectively.

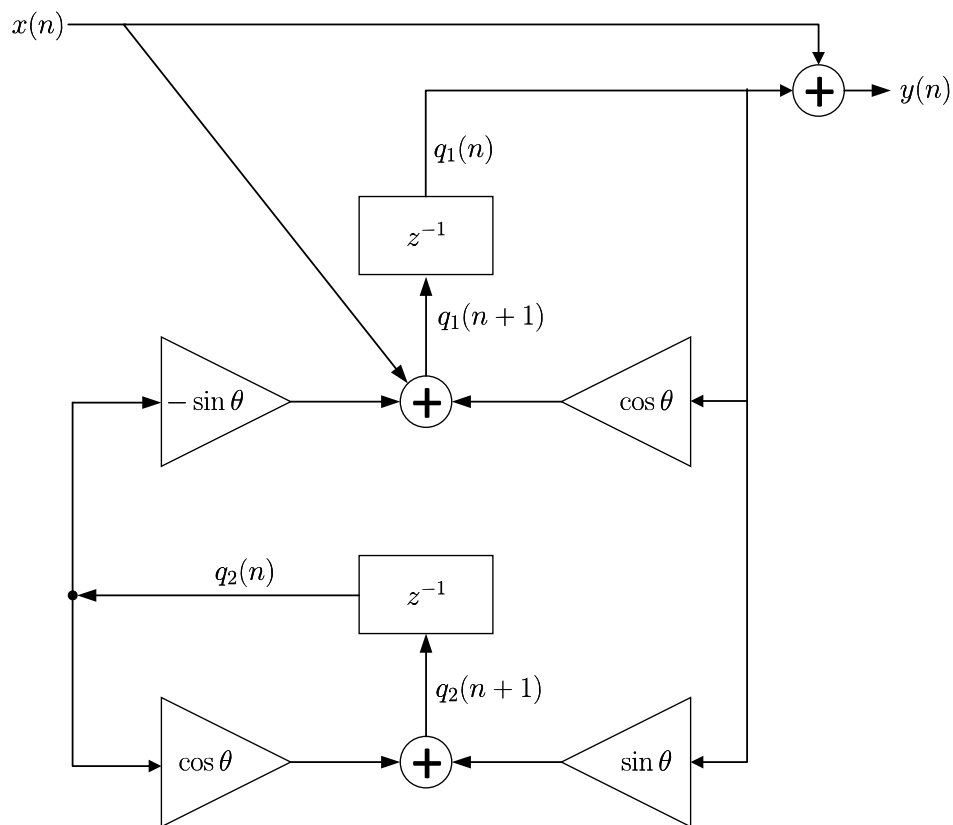

FIRST Name _____ LAST Name _____

Discussion Time: _____

SID (All Digits): _____

(a) (25 Points) Show that the state-transition matrix is the rotation matrix

$$\mathbf{A} = \begin{bmatrix} \cos \theta & -\sin \theta \\ \sin \theta & \cos \theta \end{bmatrix}$$

and also determine \mathbf{B} , \mathbf{C} and \mathbf{D} in Eqns. (1) and (2).

FIRST Name _____ LAST Name _____

Discussion Section Time: _____ SID (All Digits): _____

(b) (25 Points) Show that the state of the system at each of times $n = 1, 2, \dots$ is

$$\mathbf{q}(n) = \mathbf{A}^n \mathbf{q}(0) + \sum_{k=0}^{n-1} \mathbf{A}^{n-k-1} \mathbf{B}x(k)$$

and the output is $y(n) = \mathbf{C}\mathbf{A}^n \mathbf{q}(0) + \sum_{k=0}^{n-1} \mathbf{C}\mathbf{A}^{n-k-1} \mathbf{B}x(k) + \mathbf{D}x(n)$.

Also determine the impulse response $h(n)$ of the system.

(c) (15 Points) Suppose the input x is zero for all n , but that the system has a non-zero initial state $\mathbf{q}(0)$. Determine a reasonably-simple form for $\mathbf{q}(n)$, the state vector at time n . You should *not* have to do much work to find the higher powers of \mathbf{A} .