

Name _____ Section # _____

SID # _____

Engineering 25
Fall Semester 2017
Final Examination

Read the instructions carefully and make sure you answer all parts of each question.

Print your full name on top of every page, even if it is unused.

Time Limit: 3 hours
Closed Book Exam

Problem 1 _____ /15

Problem 2 _____ /30

Problem 3 _____ /10

Problem 4 _____ /20

Problem 5 _____ /15

Problem 6 _____ /10

TOTAL EXAM SCORE _____ /100

Problem 1 (15 points)

Starting with the original orientation each time, redraw the object shown below after the specified operations. Each rotation is 90° .

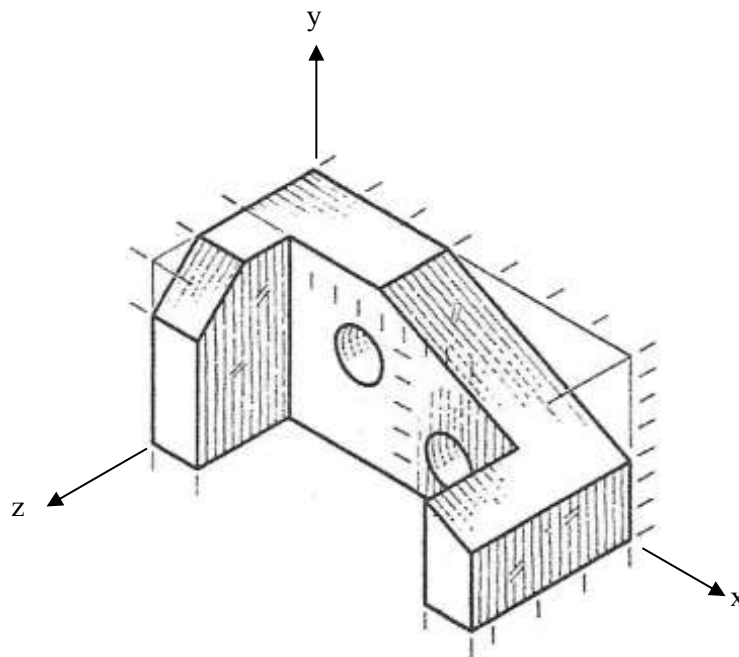
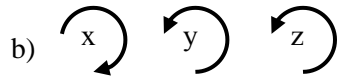

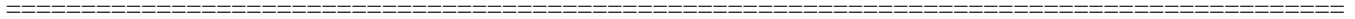

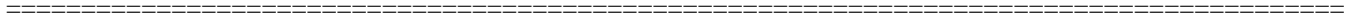

Problem 2 (30points)

Shown below are two views (in 3rd angle projection) of three different objects. Add the missing views indicated in their correct location, orientation, and scale for an engineering drawing. You do not need to add dimensions. Some reasonable drawing accuracy is expected.

a) Given the front and right side views, add the top view

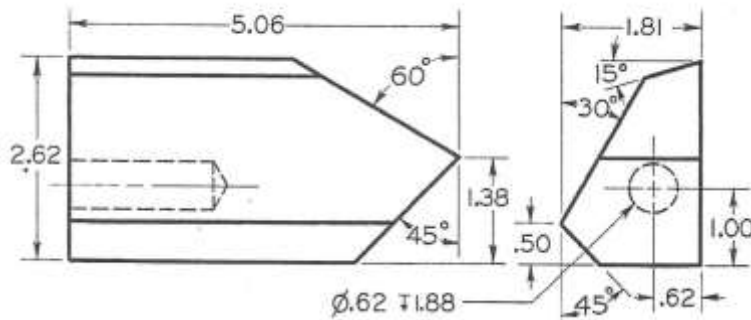

b) Given the front and top views, add the right side view.

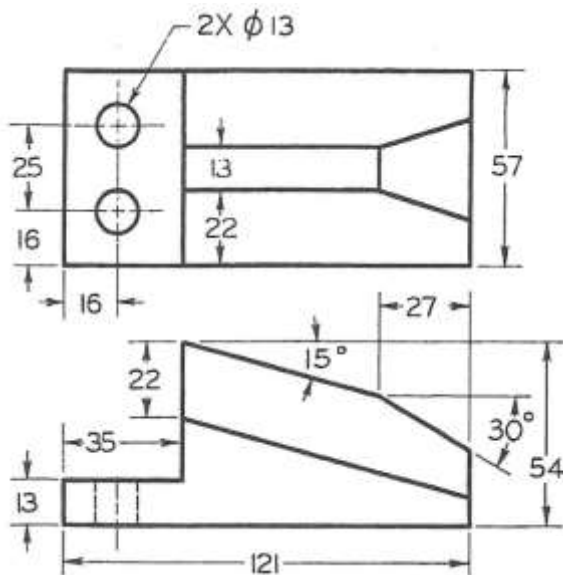

c) Given the top and right side views, add the front view.

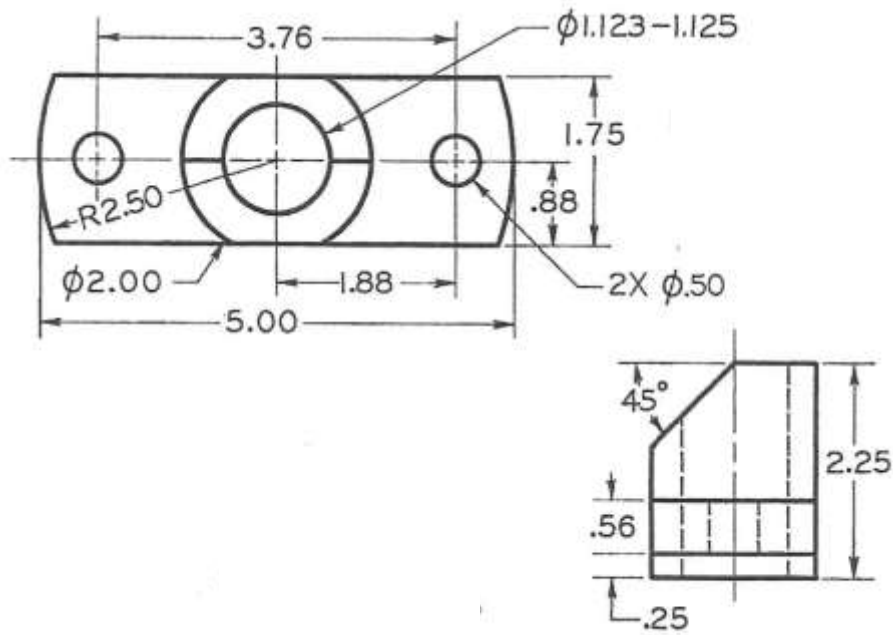

Problem 3 (10 points)

The front and top views of an object are shown below (**in 1st angle projection**). Create a partial auxiliary view that shows the true shape of the inclined surface **using 1st angle projection**. You do not need to draw the entire object in the auxiliary view. The auxiliary must be in its correct location, orientation and scale for an engineering drawing **in 1st angle projection**. You do not need to add dimensions. Some reasonable degree of drawing accuracy is expected. You do not need to show hidden lines. Do not erase your (lightweight) construction lines.

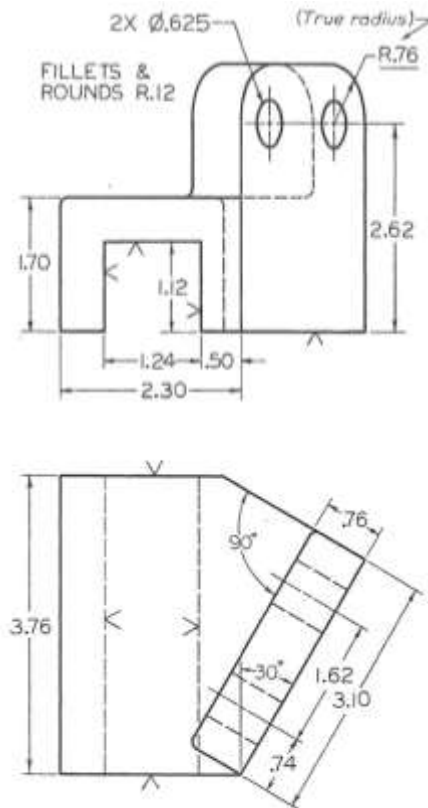

Problem 4 (20 points)

The figure below shows the front and top views of an object (in third angle projection).

- Add a properly annotated full section view A-A as the right side view. Section A-A should reveal the interior detail of the bore, the oil groove, and one of the counter-bored holes. You do not need to include hidden lines in the section view.
- Sketch an isometric pictorial that shows the front, top, and revealed right side view after the object has been cut. You do not need to include hidden lines, dimensions, or shading in the pictorial.

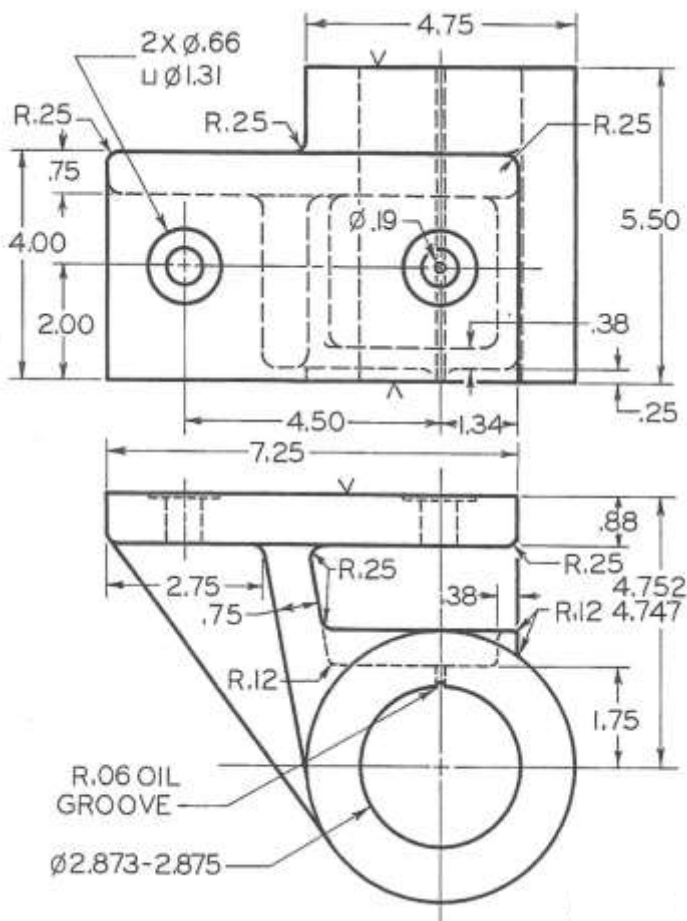

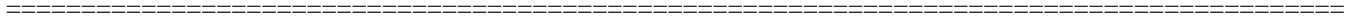

Problem 5 (15 points)

Three views of an object are shown below in third angle projection. The dimensions on the drawing have been hidden for convenience. It is desired to make the drawing fully parametric by adding the necessary geometric and associative constraints so that changing any dimension will correspondingly change the geometry in all three views, including the hidden lines. Tag each line or curve on the drawing with a number, and specify the geometric or associative constraint that must be added. This must be done for all views. The first two curves have been started (but may or may not be complete) as an example.

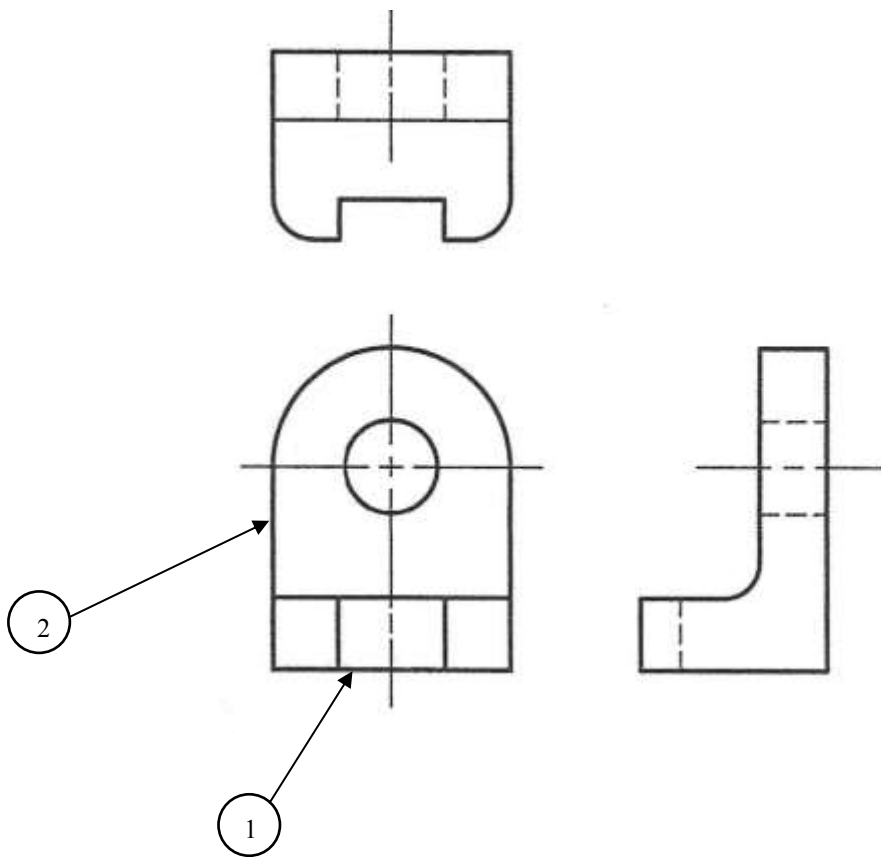

Item#	Constraints
1	Horizontal, endpoint coincident to 2, ... (please complete...)
2	Vertical, endpoint coincident to 1, ... (please complete...)
3	

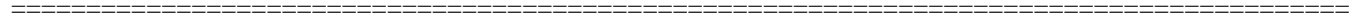

4

- .
- .
- .
- .

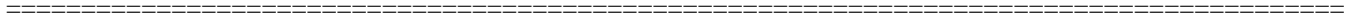

=====

Problem 6 (10 points)

- a) Describe four advantages of using a 2-dimensional drawing program such as AutoCAD for making drawings instead of a 3-dimensional modeler such as Solidworks, Inventor, or Creo.

- b) When working with a 2-dimensional drawing program such as AutoCAD, describe three problems that may be encountered when editing a drawing that has been translated from a drawing made from a solid modeler such as Solidworks, Inventor, or Creo.

