

# CBE 142: Chemical Kinetics & Reaction Engineering

Midterm #1  
October 10<sup>th</sup>, 2019

This exam is worth 100 points and 26% of your course grade. You have 80 minutes to complete this exam, so please manage time wisely. Please read through the questions carefully before giving your response. **Make sure to SHOW ALL YOUR WORK and BOX your final answers! Answers without a clear and legible thought process will receive no credit.**

Name (Print clearly): \_\_\_\_\_

Student ID (Print clearly): \_\_\_\_\_

Section (Day/GSI) that you **attend**: \_\_\_\_\_

You are allowed one 8.5''x11'' sheet of paper (front and back) and a calculator for this exam. Any additional paper you wish to be graded must have your **NAME** and **STUDENT ID** written on each page.

<b>Problem</b>	<b>Max Points</b>	<b>Points Earned</b>
1	25	
2	25	
3	25	
4	25	

**TOTAL : \_\_\_\_\_ / 100**



**Problem 1** (25 points)

- a) (10 points) Rank the following reactor configurations in order of conversion from highest to lowest (ties are not impossible) when a 1st order, isothermal, isobaric, liquid-phase reaction is considered at steady-state.

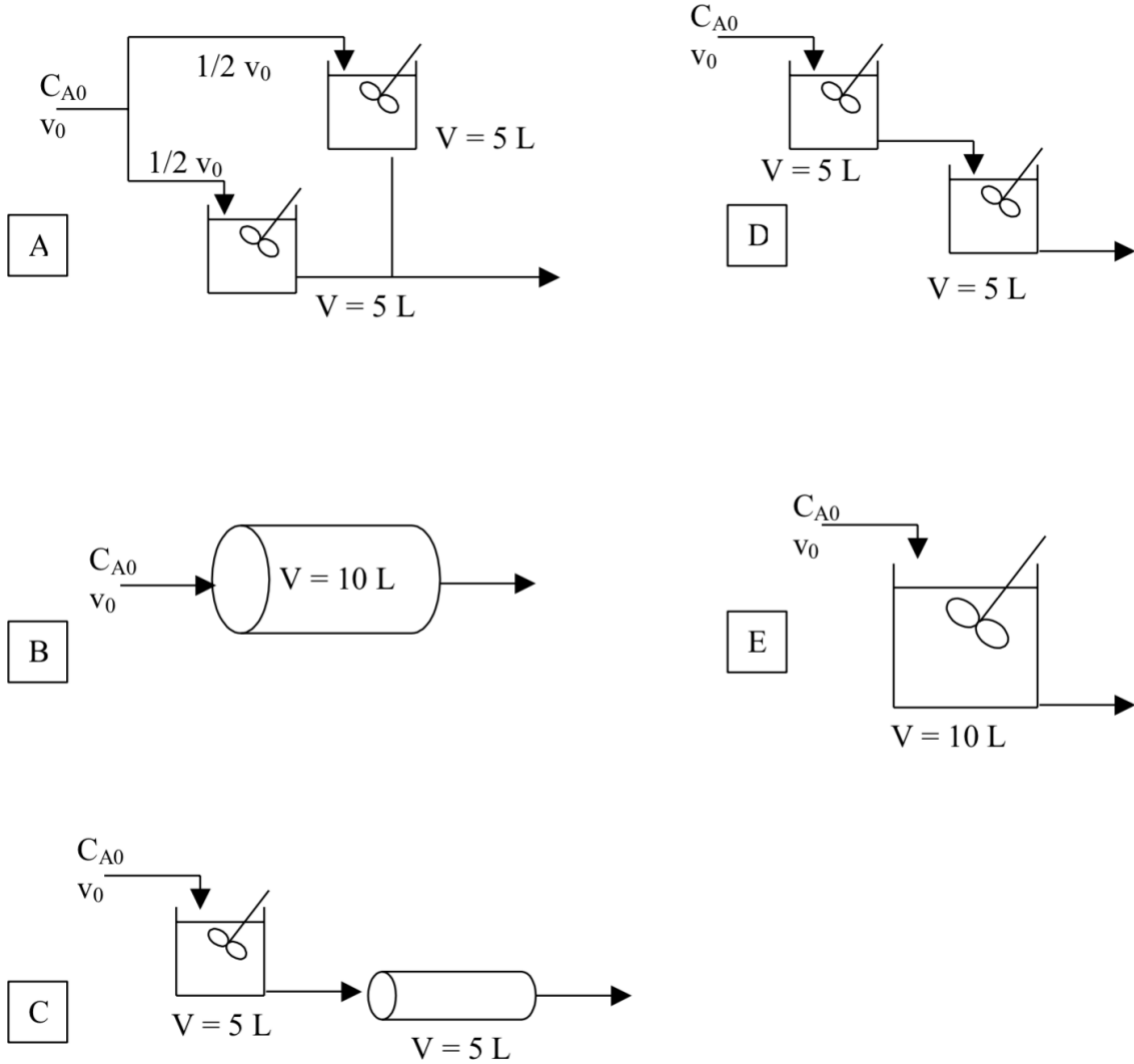

Write final answer in this box:



- b) (15 points) Consider the following (identical) Levenspiel plots for the reaction  $A \rightarrow B$ . Assume the reactor feed is pure A and that operation is isothermal, isobaric, liquid-phase and at steady-state. Duplicate plots are provided to help you when solving the problem.

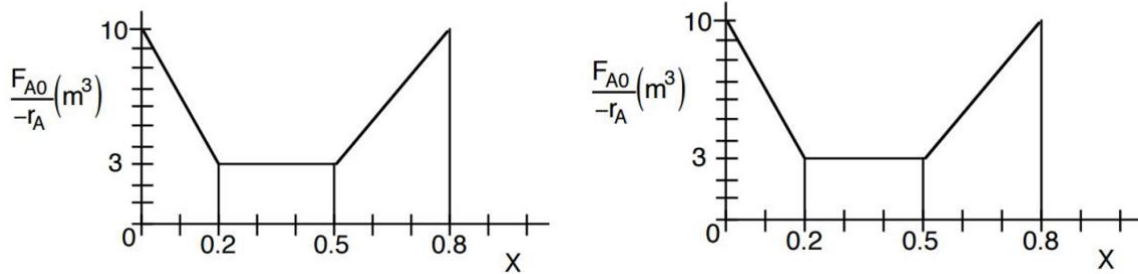

- i. At which conversion(s) ( $X$ ) is the volume of a single CSTR **less** than a single PFR?  
Select all answers that apply:

- |        |        |
|--------|--------|
| a) 0.2 | b) 0.5 |
| c) 0.7 | d) 0.8 |

- ii. At which conversion(s) ( $X$ ) is the volume of a single PFR **less** than a single CSTR?  
Select all answers that apply:

- |        |        |
|--------|--------|
| a) 0.2 | b) 0.5 |
| c) 0.7 | d) 0.8 |



- iii. Calculate the difference in volume of a CSTR and a PFR used for this reaction to bring conversion from  $X = 0$  to 0.4. Which reactor is smaller?
- iv. Propose a reactor configuration that minimizes the number of reactors and their volumes while achieving 80% conversion. State the number, volume of each, type, and order of reactors you would choose.





**Problem 2** (25 points)

Lobree et al. published a paper in 1998 describing how methane reduces supported Pd ions on ZSM-5 zeolites into Pd product. We provide a simplified mechanism in terms of letters below:

Elementary Steps	Rate constants	$\sigma$
$A + CH_4 \leftrightarrow B + H_2O$	$k_1, k_{-1}$	
$B \rightarrow 2C$	$k_2$	
$C \rightarrow D + CO$	$k_3$	
$2D \rightarrow 2E + Pd$	$k_4$	

The net, overall reaction is as follows:  $A + CH_4 \rightarrow 2E + Pd + 2CO + H_2O$   
Assume all intermediates are reactive intermediates.

- a) (12 points) Derive the rate law expression for the formation of Pd in terms of reactants, products, and rate constants. Also find the stoichiometric number for each step and fill it into the table above.



b) (4 points) Using your result in part a, find the rate of formation of CO in terms of reactants and products.

c) (5 points) Derive the Pd rate of formation expression (i.e. re-do part a) if step 1 is in quasi-equilibrium.



- d) (4 points) Now, we'll explore a rigorous justification for QEA. Under what conditions does your solution for part a collapse into your solution for part c? Do the following to answer this question.
- i. Provide a specific inequality.
  - ii. Draw a rate arrow diagram for the PSSH and QEA cases.



**Problem 3** (25 points)

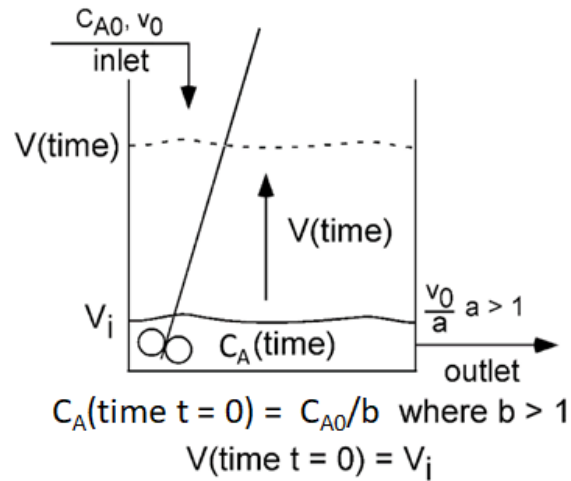

Consider the start-up of an ideal isothermal CSTR reactor. The vessel initially contains a solution of dye with a concentration,  $C_{A0}/b$ , where  $b$  is a constant that is greater than 1, and a volume  $V_i$ . Both inlet and outlet ports are turned on at time  $t=0$ . The inlet port flows with a volumetric flow rate,  $v_0$ , and a concentration,  $C_{A0}$ . The outlet port flows with a volumetric flowrate  $v_0/a$ , where  $a$  is a constant that is greater than 1. Assume that the reactor vessel is large enough that it does not overflow in the timescale with which we are concerned.

- a) (5 points) Write an expression for the reactor volume as a function of time,  $V(t)$ .





- b) (10 points) Derive an expression for the change in concentration of A in the reactor over time,  $dC_A/dt$ , as a function of  $C_A$ ,  $t$  and constants given in the problem statement.



c) (5 points) What is the sign of  $dC_A/dt$ ? Explain why in 1 sentence.

d) (5 points) Now assume that A can undergo an irreversible, monomolecular rearrangement to B with rate  $k_1$ . Write an expression for  $dC_A/dt$  for this case.



**Problem 4** (25 points)

A cylindrical variable-volume BSTR that is spring loaded, as shown in the figure below, is used to conduct a reversible elementary reaction  $A \rightleftharpoons 3B$  in the gas phase, with rate constants  $k_1$  and  $k_{-1}$  in the forward and reverse directions, respectively. Assuming a cross-sectional area of  $A_c$ , and a Hooke's law constant for the spring of  $F = -C * z$ , where  $z$  is the displacement shown in the figure below, answer the questions below. The reactor operates isothermally at a temperature of  $T_0$ , and is initially loaded with equimolar amounts of A and inert, each of which is present at an initial molar amount  $N_{A0}$ . Assume all species to behave as ideal gases, and all units are SI with molar quantities in moles.

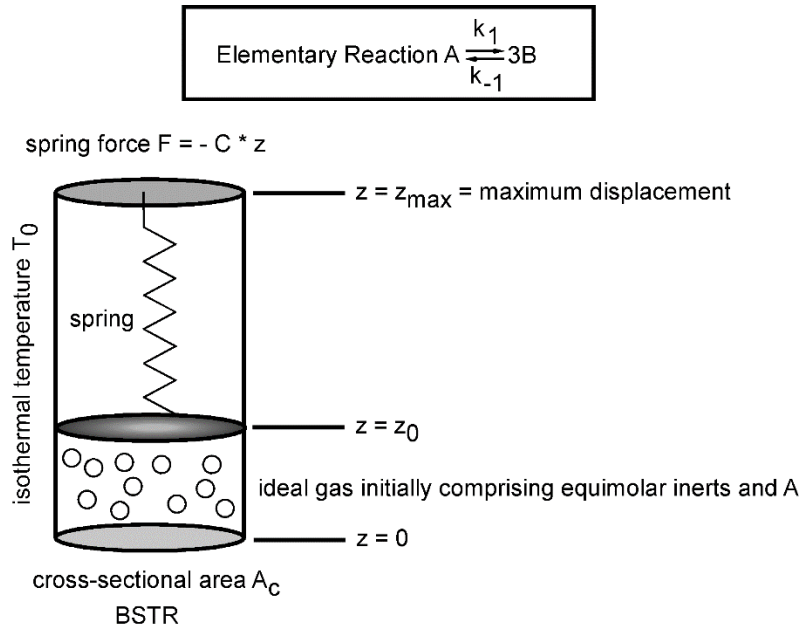

- a) (5 points) Write an expression for the initial displacement  $z_0$  as a function of other variables given in the problem text above.



- b) (15 points) Write the rate law in terms of conversion of A,  $X_A$ , and other variables given in the problem text above.





- c) (5 points) Write an implicit equation but do not solve it for the equilibrium conversion of A,  $X_{EQ}$ .

