

Name \_\_\_\_\_ Section # \_\_\_\_\_

SID # \_\_\_\_\_

Engineering 25  
Spring Semester 2019  
Final Examination

*Read the instructions carefully and make sure you answer all parts of each question.*

*Print your full name on top of every page, even if it is unused.*

Time Limit: 3 hours  
Closed Book Exam

Problem 1 \_\_\_\_\_ /18

Problem 2 \_\_\_\_\_ /20

Problem 3 \_\_\_\_\_ /15

Problem 4 \_\_\_\_\_ /22

Problem 5 \_\_\_\_\_ /25

TOTAL EXAM SCORE \_\_\_\_\_ /100

**Problem 1** (18 points)

The 12 sets of orthogonal drawings shown (in 3<sup>rd</sup> angle projection) below may have missing visible or hidden lines. Add the missing lines with their correct line type. Any choice of lines that results in consistent information from all three views is acceptable.

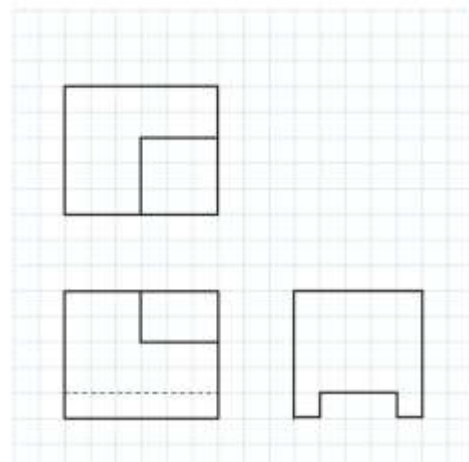
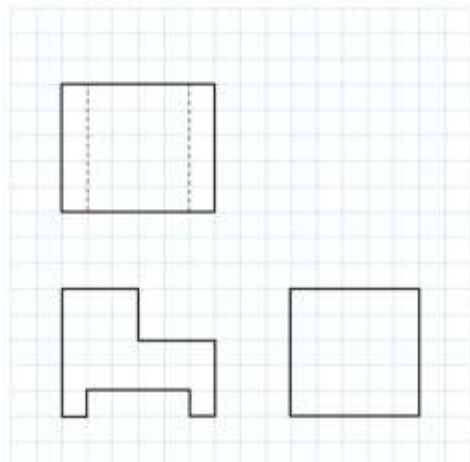
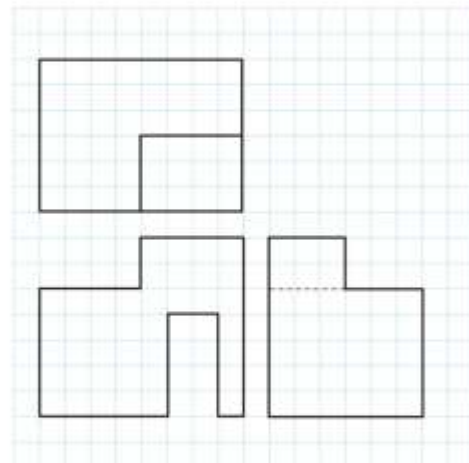
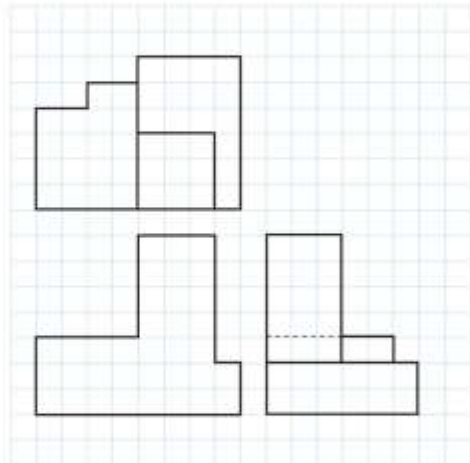
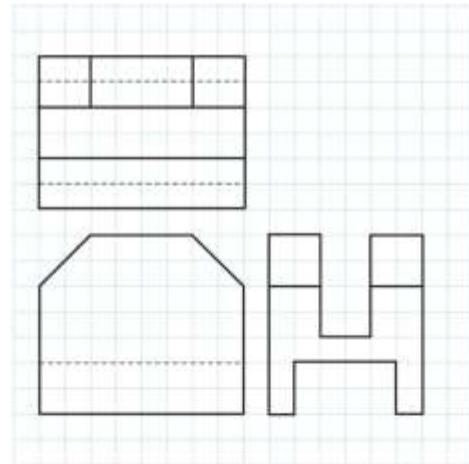
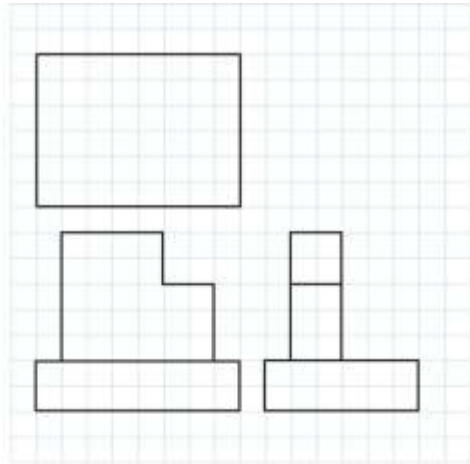

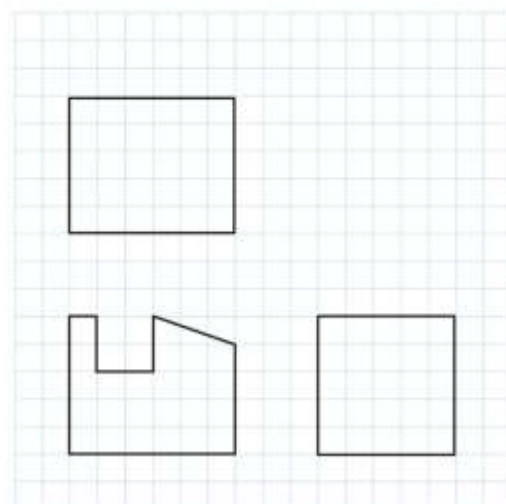
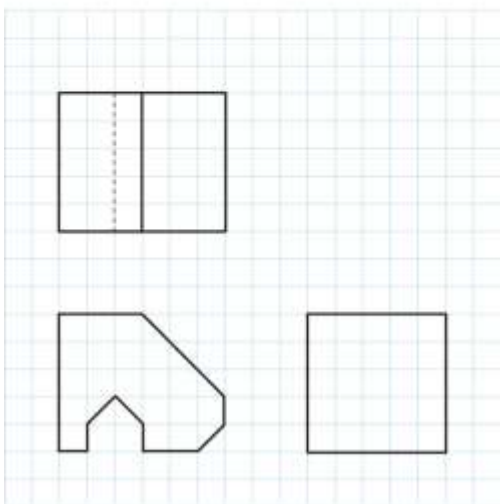
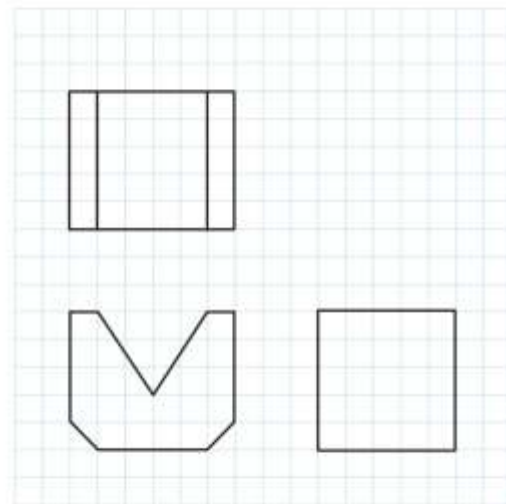
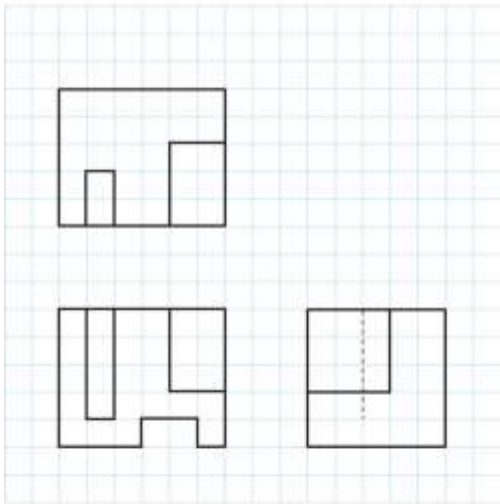
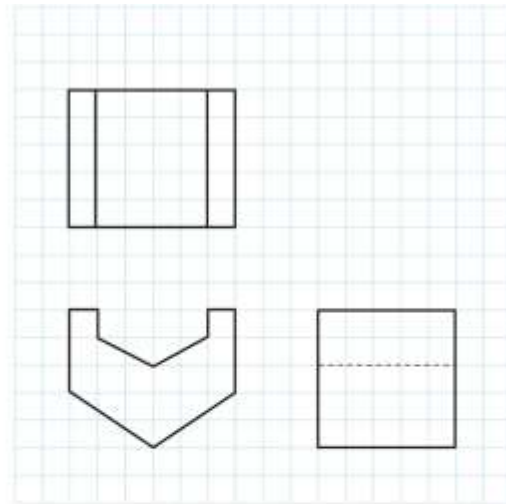
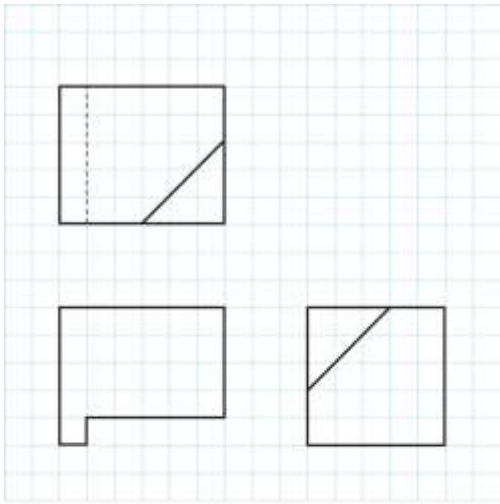

**Problem 2** (20 points)

The figure below shows a pictorial drawing of bearing support bracket. The pictorial shows the front, top and right sides of the part.

- a) Sketch a multi-view drawing of the bracket, using **1<sup>st</sup> angle projection**, showing the front, top, and right side views. Use sufficient hidden lines to ensure every feature is well-defined. Include a single full section view that shows the  $\text{Ø}44.45$  mm bore and the  $\text{Ø}17.5$  mm hole.

Center-lines and center-marks must be included. Exact sizes are not required, but reasonably accurate proportions are expected. You do not need to show the dimensions.

- b) Sketch an isometric pictorial that shows the bracket after it has been hypothetically cut. Crosshatch the areas that were formerly solid. You do not need to include hidden lines, dimensions, or shading in the pictorial.

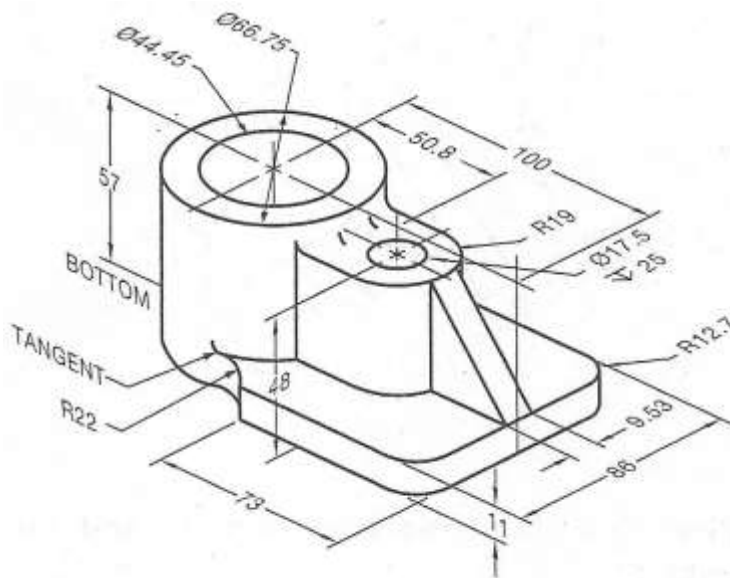

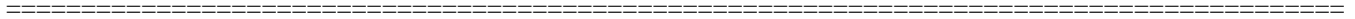

**Problem 3** (15 points)

The figure below shows a pictorial of a part that is intended to be symmetrical. Sketch a multi-view drawing of the bracket, using **3<sup>rd</sup> angle projection**, showing the front, top, and right side views. Use sufficient hidden lines to ensure every feature is well-defined. Center-lines and center-marks must be used when needed. Exact sizes are not required, but reasonably accurate proportions are expected.

Dimension the multi-view drawing such that all features are fully defined (but also not over-dimensioned). Dimensions do not need to be exact but should be believable based on proportions.

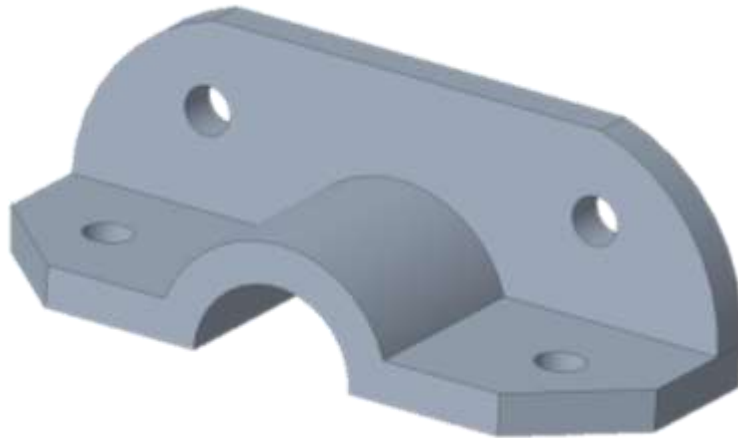

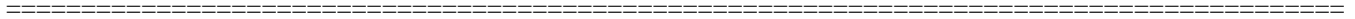

**Problem 4** (22 points)

For the object shown below, the front and an auxiliary views are shown (in 3<sup>rd</sup> angle projection). Add the top and right side views in their correct location and orientation.

You will note that two of the object's surfaces are oblique, i.e. they are not visible in edge view in any of the six standard (glass box) views. Add a second auxiliary view that shows one of the oblique surfaces in its true shape. You do not need to add dimensions, but some reasonable drawing accuracy is expected.

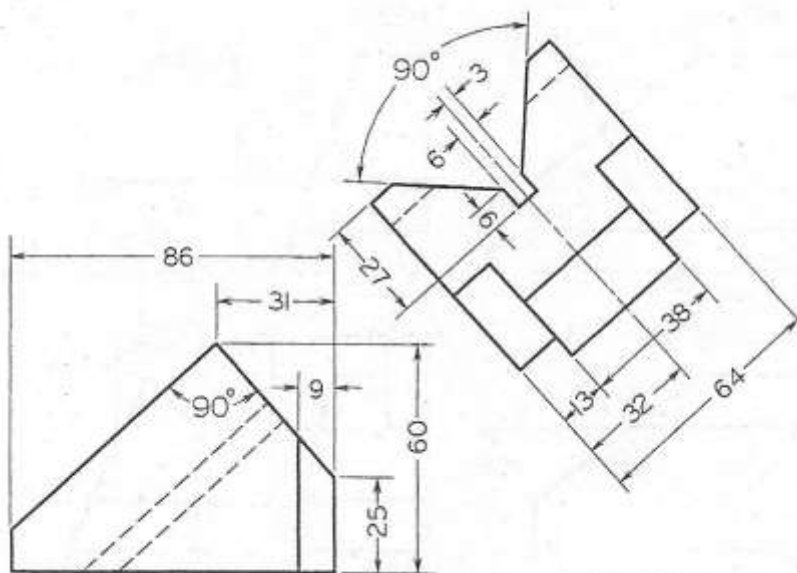



**Problem 5** (25 points)

The drawing below shows the front and top views of an object (in 3<sup>rd</sup> angle projection).

- Add a right side view that includes all hidden lines, centerlines, and center-marks. You do not need to add dimensions to the right side view.
- Sketch an isometric pictorial that shows the front, top, and right side view after the object. You do not need to include hidden lines, center lines or center-marks, dimensions, or shading in the pictorial.

