

Name \_\_\_\_\_ Section # \_\_\_\_\_

SID # \_\_\_\_\_

Engineering 25  
Fall Semester 2014  
Final Examination

*Read the instructions carefully and make sure you answer all parts of each question.*

*Print your full name on top of every page, even if it is unused.*

Time Limit: 3 hours  
Closed Book Exam

Problem 1 \_\_\_\_\_ /16

Problem 2 \_\_\_\_\_ /24

Problem 3 \_\_\_\_\_ /12

Problem 4 \_\_\_\_\_ /16









Problem 5 \_\_\_\_\_ /16

Problem 6 \_\_\_\_\_ /16

TOTAL EXAM SCORE \_\_\_\_\_

**Problem 1** (16 points)

Starting with the original orientation each time, redraw the object shown below after the specified operations.

- a)  
- b)   
- c)   

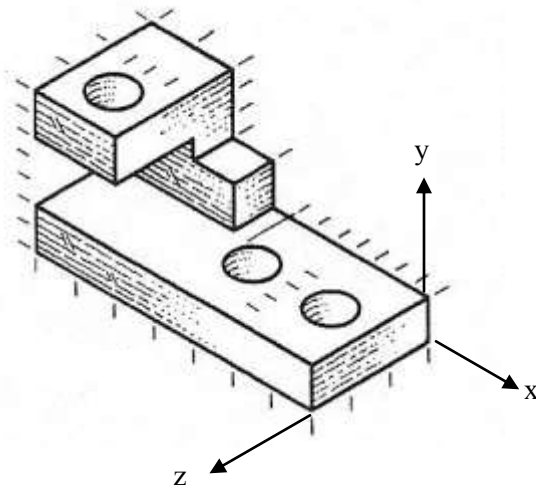

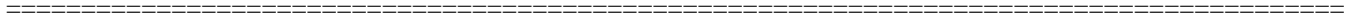

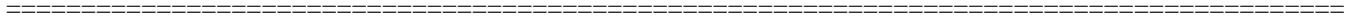

**Problem #2** (24 points)

Shown below are the front, top and right side views of 16 different objects (in third angle projection). Each set of views may have one or more missing visible or hidden lines. Add the missing lines to the appropriate views.

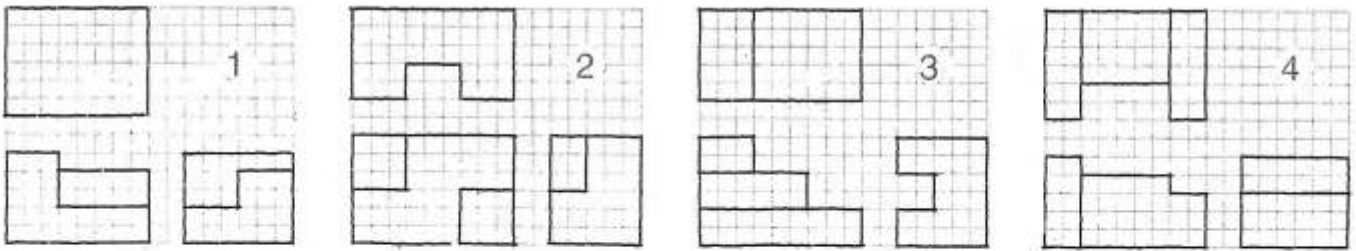

*Probs 1-5: No inclined or oblique surfaces.*

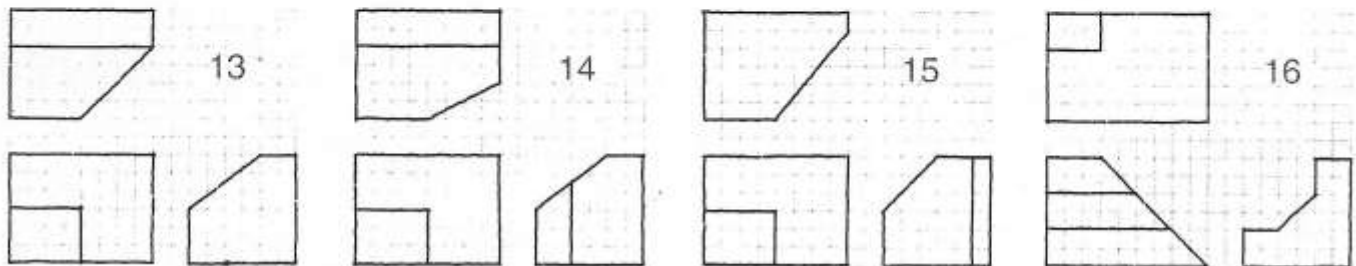
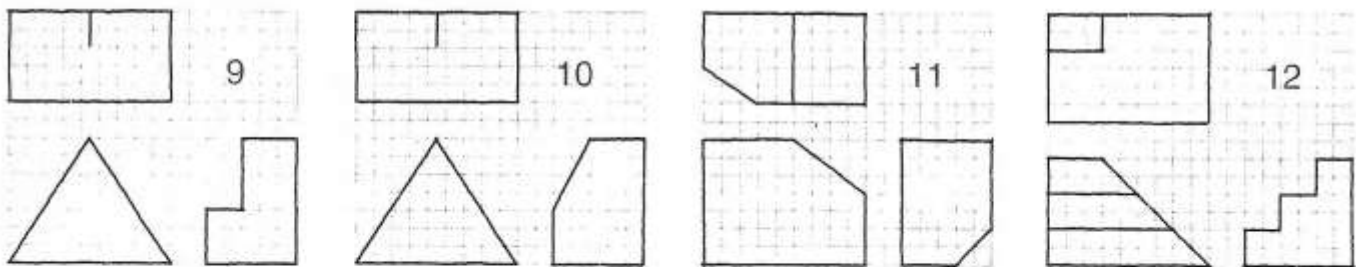
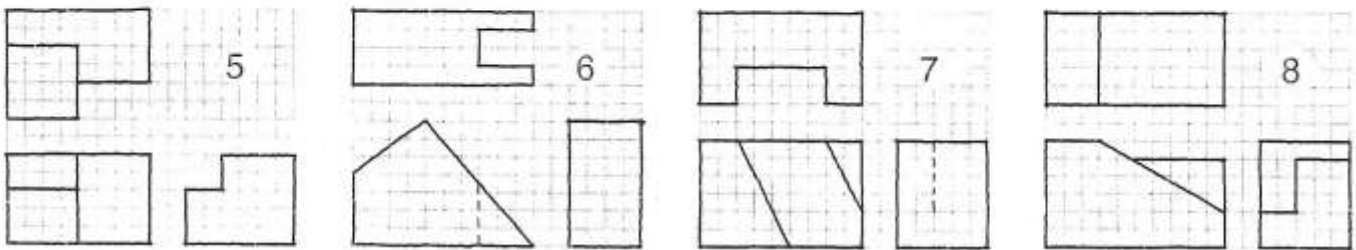

**Problem 3** (12 points)

The figure below shows the front and right side views of an object (in third angle projection).

- a) Add a top view in its correct location, orientation, and scale. Include all hidden lines. It is not necessary to add dimensions to the top view.
- b) Sketch an isometric pictorial that shows the front, top and right sides. You do not need to include hidden lines, dimensions, or shading in the pictorial.

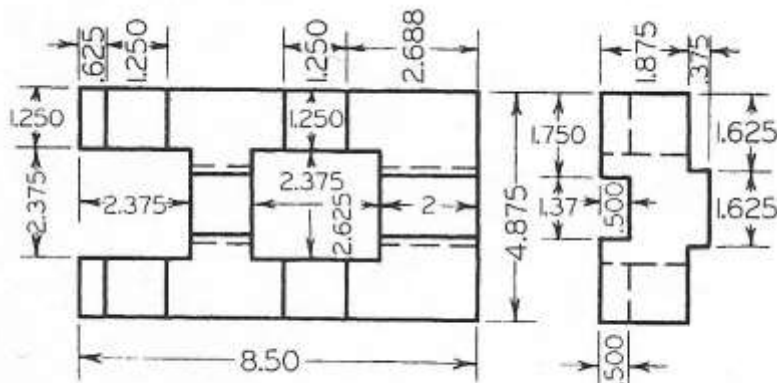

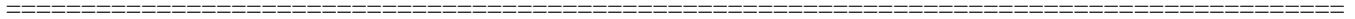





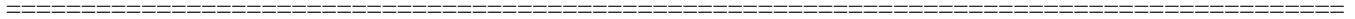



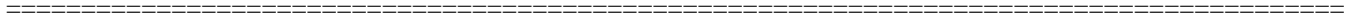

**Problem 6** (16 points)

The front and top views of an object are shown below in third angle projection. The dimensions shown are sufficient to fully define its geometry. It is desired to make the drawing fully parametric by adding the necessary geometric and associative constraints so that changing any dimension will correspondingly change the geometry in both views. On the following page, the dimensions on the drawing have been hidden for convenience. Tag each curve on the drawing with a number, and specify the geometric or associative constraint that must be added. This must be done for both the front and the top views. Do not add additional dimensional constraints. Provisions to maintain space between the two views do not need to be included. The first two curves have been started (but may or may not be complete) as an example.

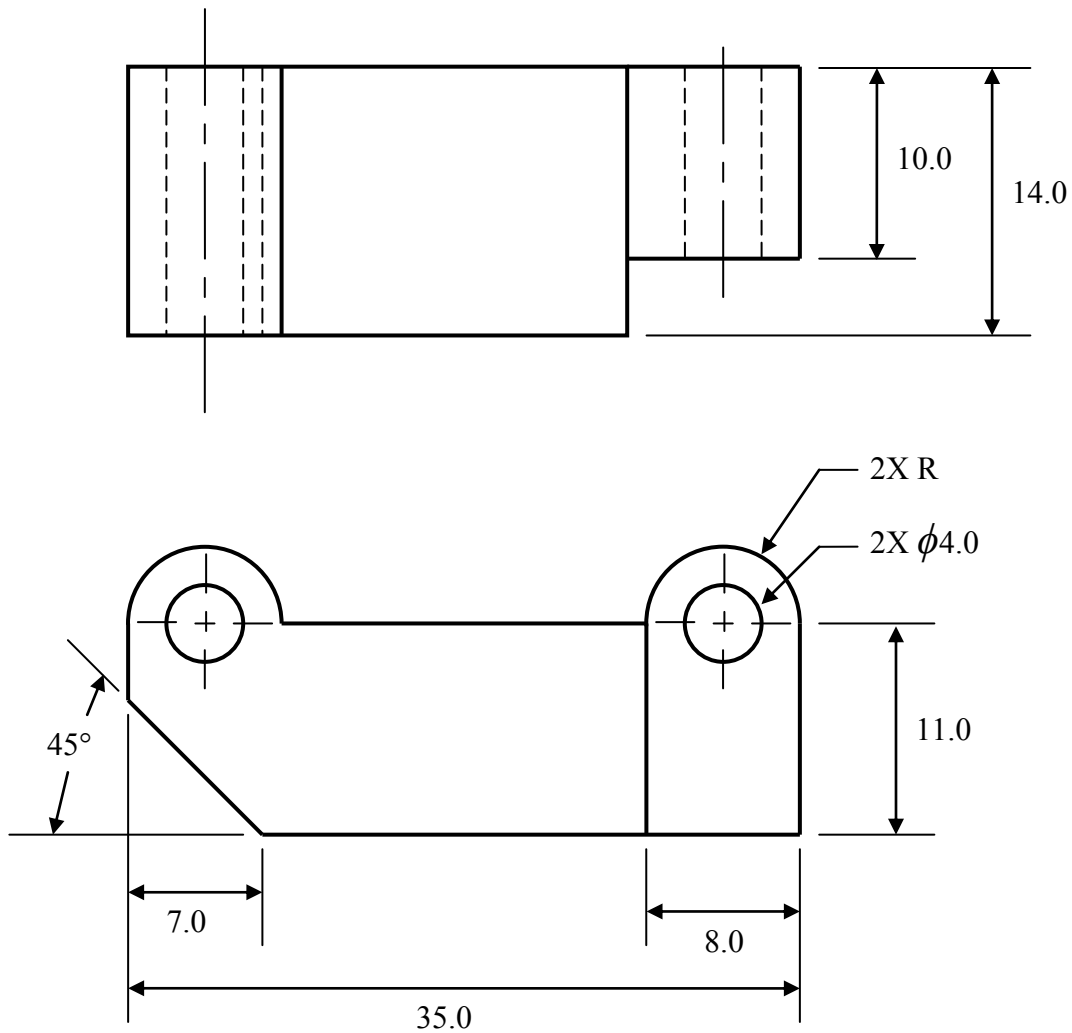

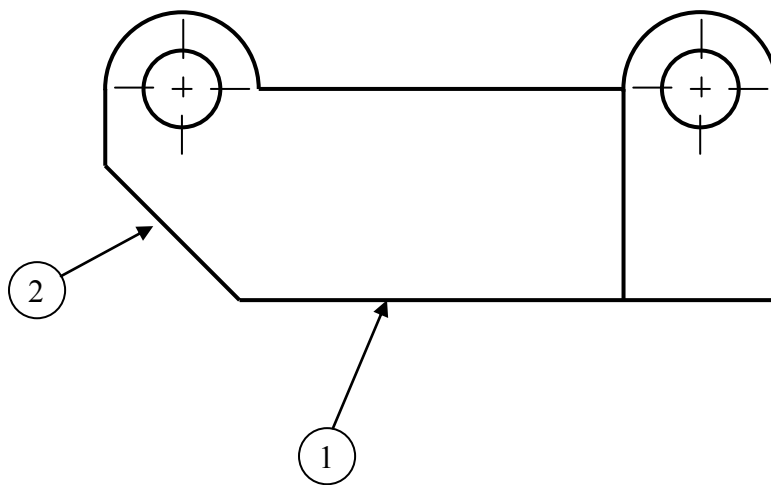
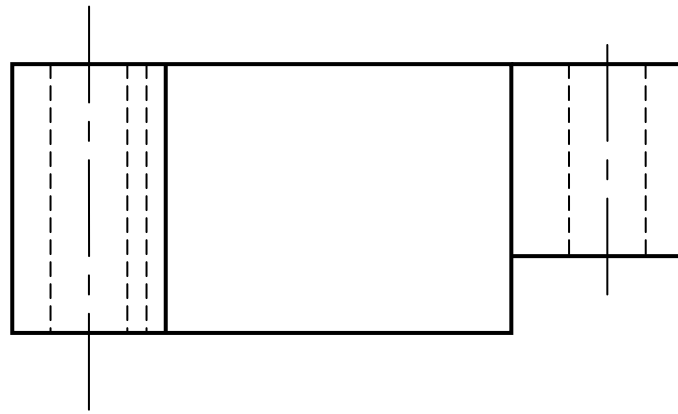

Item#            Constraints

- 1    Horizontal, endpoint coincident to 2,
- 2    Endpoint coincident to 1,
- 3
- 4
- .
- .
- .
- .

