

Exam 2 Solution

May 10, 2019

Problem 1

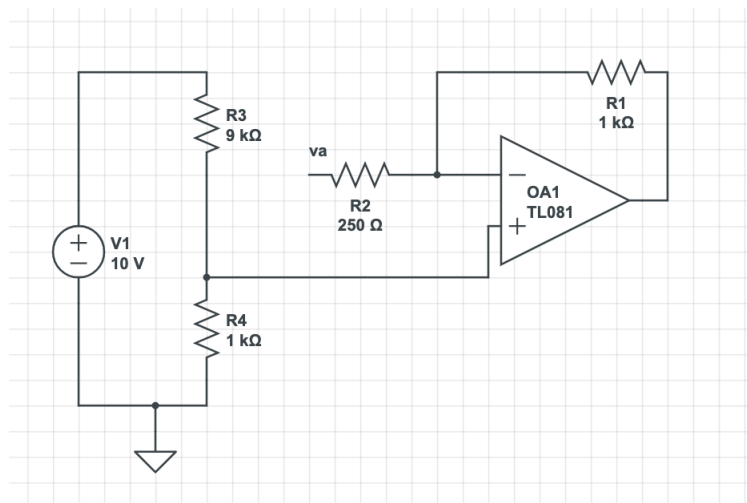

Let's use superposition. For $v_{o1} = -4v_a$, output because of v_a .

$$v_{o1}/v_a = -R_1/R_2 = -4$$

$$R_2 = R_1/4 = 250 \Omega$$

Now, output because of positive terminal voltage, v_+ is, $v_{o2} = 5 V$.

$$v_{o2}/v_+ = 5 = 1 + R_2/R_1 = 5$$

$$v_+ = 1 V$$

$$v_+ = \frac{R_4}{R_3 + R_4} V_1$$

$$R_3 = 9R_4$$

We can choose R_4 to be 1 k Ω and R_3 to be 9 k Ω , but other values are acceptable keeping the ratio same.

Problem 2

The voltage in the capacitor drops while the plane operates, but the current remains constant. We know,

$$i_{C_s} = C \frac{dv_{C_s}}{dt}.$$

So, if current is constant the voltage drops linearly across, C_s . Here, initial voltage across C_s is $V_1 = 8$ V and final voltage, $V_2 = 5$ V. So, energy delivered,

$$E = \frac{V_1 + V_2}{2} It.$$

Also, energy delivered can be calculated using the difference of energy stored in the capacitor initially and finally.

$$E = \frac{1}{2}(C_s V_1^2 - C_s V_2^2).$$

So,

$$\begin{aligned} \frac{V_1 + V_2}{2} It &= \frac{1}{2}(C_s V_1^2 - C_s V_2^2) \\ (8 + 5) \cdot 100 \cdot 10^{-3} \cdot 10 \cdot 60 &= C_s(8^2 - 5^2) \\ C_s &= 20 \text{ F} \end{aligned}$$

Problem 3

Both of the waveforms have same period, $T = 3$ s. For the sinusoidal waveform, $V_{rms,sin} = V_m/\sqrt{2} = 2/\sqrt{2} = \sqrt{2}$ V.

For the triangular wave we have to calculate the rms value.

$$V_{rms} = \sqrt{\frac{1}{T} \int_0^T v^2(t) dt}$$

Now, the triangular wave is antisymmetric and if we square it will become symmetric. ON top of that, if we divide the whole period of the triangular waveshapes into four equal segments then the squared triangular wave will have same area under each fraction. So,

$$V_{rms,tri} = \sqrt{\frac{4}{T} \int_0^{T/4} v^2(t) dt} = \sqrt{\frac{4}{T} \int_0^{T/4} \left(\frac{8t}{3}\right)^2 dt} = \frac{2}{\sqrt{3}}$$

So,

$$P_{rms,sin}/P_{rms,tri} = (P_{rms,sin}/P_{rms,tri})^2 = \left(\frac{\sqrt{2}}{\frac{2}{\sqrt{3}}}\right)^2 = 3/2$$

Problem 4

Piecewise linear version of the following plot

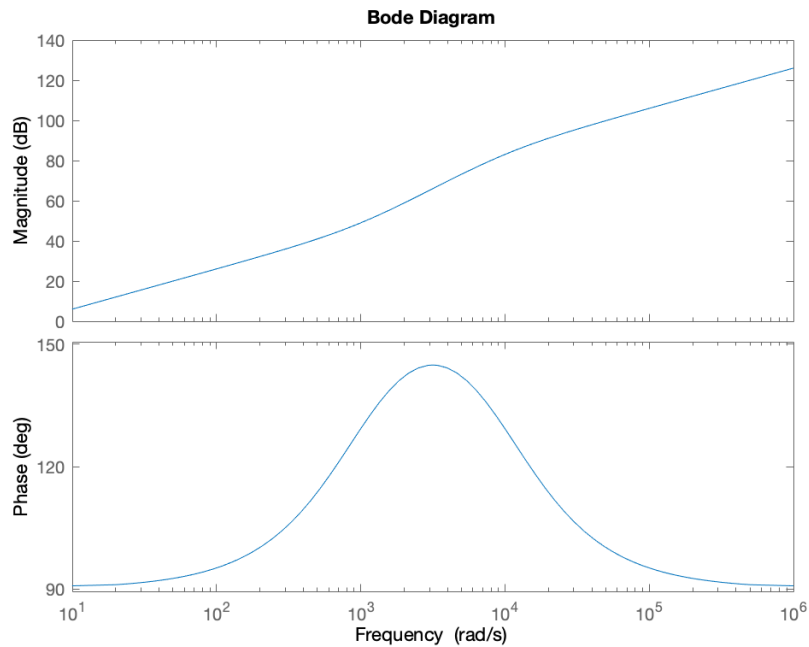

Problem 5

(a) Here, $\mathbf{I}_m = 10\angle 0^\circ$ and $\mathbf{Z}_1 = 30\angle -40^\circ$. So,

$$\mathbf{V}_m = \mathbf{I}\mathbf{Z}_1 = 300\angle -40^\circ$$

$$\begin{aligned} P &= 0.5V_m I_m \cos(\theta_v - \theta_i) \\ P &= 0.5 \cdot 10 \cdot 300 \cdot \cos(-40^\circ - 0^\circ) \\ P &\approx 1149 \text{ W} \end{aligned}$$

(b) For power factor to be unity, the equivalent impedance angle of the series combination needs to be 0° . So, the imaginary part of the equivalent impedance needs to be 0. Now, the imaginary part of \mathbf{Z}_1 is $30\sin(-40^\circ) = -j19.28 \Omega$. So, \mathbf{Z}_2 can be any impedance with imaginary part 19.28Ω .

Problem 6

(a) at $\omega = 0$, C_1 is open and $v_+ = 0$ V. So, $v_o = 0$.

$$v_2/v_1 = 0$$

(b) at $\omega \rightarrow \infty$, C_1 is short and $v_+ = v_1$ V. However, C_2 is also short, so, $v_2 = 0$.

$$v_2/v_1 = 0$$

(c)

$$H(j\omega) = \frac{V_2(j\omega)}{V_1(j\omega)} = \frac{R_1}{R_1 + \frac{1}{j\omega C_1}} \frac{\frac{1}{j\omega C_2}}{R_2 + \frac{1}{j\omega C_2}} = \frac{j\omega R_1 C_1}{(1 + j\omega R_1 C_1)(1 + j\omega R_2 C_2)}$$

(d) In part (c) if $\omega = 0$, the magnitude of H is obviously 0.

If $\omega \rightarrow \infty$, $j\omega R_1 C_1$ and $j\omega R_2 C_2$ are much greater than 1. So,

$$H(j\omega) = \frac{j\omega R_1 C_1}{j\omega R_1 C_1 \cdot j\omega R_2 C_2} = \frac{1}{j\omega R_2 C_2} \approx 0$$