

University of California
 Department of nuclear Engineering

NE 124 Mid-Term Examination II

Fall 2006
 Professor J. Ahn

CLOSED BOOK

12:40 pm – 2:00 pm, November 21, 2006

(Undergraduate students: choose any 4 problems, and answer.

Graduate students: answer all 5 problems.)

1. (15 points) Check the correct one:

(1) (5 points) Package containing Cs-137 in concentration of 40 Ci/m³ and Tc-99 in 4 Ci/m³:

a. _____ b. _____ c. _____ d. _____ e. _____
 Class A LLW Class B LLW Class C LLW GTCC LLW not LLW

(2) (5 points) package containing Np-237 in concentration of 80 nCi/g and Sr-90 in concentration of 100 Ci/m³:

a. _____ b. _____ c. _____ d. _____ e. _____
 Class A LLW Class B LLW Class C LLW GTCC LLW not LLW

(3) (5 points) Depleted uranium

a. _____ b. _____ c. _____ d. _____ e. _____
 Class A LLW Class B LLW Class C LLW GTCC LLW not LLW

A. ACTIVITY CONCENTRATIONS USED FOR THE CLASSIFICATION OF LLW[†]

Nuclide	Concentration (Ci/m ³)
¹⁴ C	8
¹⁴ C in activated metal	80
⁵⁹ Ni in activated metal	220
⁹⁴ Nb in activated metal	0.2
⁹⁹ Tc	3
¹²⁹ I	0.08
Alpha-emitting TRU with $T_{1/2} > 5$ yr	100 (nCi/g)
²⁴¹ Pu	3500 (nCi/g)
²⁴² Cm	20000 (nCi/g)

B.

Nuclide	Concentration (Ci/m ³)		
	Column 1	Column 2	Column 3
All nuclides with $T_{1/2} < 5$ yr	700	*	*
³ H	40	*	*
⁶⁰ Co	700	*	*
⁶³ Ni	3.5	70	700
⁶³ Ni in activated metal	3.5	700	7000
⁹⁰ Sr	0.04	150	7000
¹³⁷ Cs	1	44	4600

[†] From Ref. 4

2. (15 points) Consider the extraction of uranium, with the N -stage extraction process shown in the figure. Assume that at each stage, the distribution coefficient between the two phases at equilibrium is D . The organic solvent is supplied to the first stage at the flow rate of E liters/sec with zero uranium concentration ($y_0 = 0$). The extract is obtained at stage N with the uranium concentration of y_N moles/liter. At Stages N , the feed flow is injected at the flow rate of F liters/sec with the uranium concentration of x^F moles/liter. At stage 1, the raffinate flows out at the rate of F liters/sec at the concentration of x_1 moles/liter.

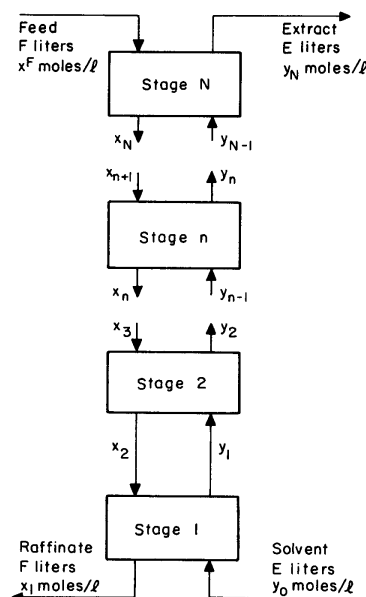

- (1) (5 points) Write the expression for the operating line.
- (2) (5 points) Write the definitions of the overall recovery ρ and the extraction factor β in terms of the distribution coefficient D , the flow rates E and F and the concentrations shown in the figure.
- (3) (5 points) Assuming that the distribution coefficient D is constant, express ρ in terms of β and N .

3. (15 points) Use the data shown in the table below if necessary.

$$1 \text{ Ci} = 3.7\text{E}10 \text{ Bq.}$$

- (1) (5 points) Calculate the ingestion toxicity index ($\text{m}^3\text{-water}$) for 1 gram of pure uranium-238.
- (2) (5 points) Assuming that secular equilibrium is established in uranium ore among uranium isotopes and their decay daughters, which radionuclide is the most toxic in the uranium ore? Why?
- (3) (5 points) Assume that at the milling process uranium isotopes could be separated completely from their decay daughters (i.e., in the mill tailings no uranium isotopes are included while in the yellow cake no decay daughters are included). Sketch the radiotoxicity of the mill tailings that is generated for getting 1 g of natural uranium as a function of time in a log-log plot.

Nuclide	Half-life	MPC for ingestion ($\mu\text{Ci/ml}$)	Nuclide	Half-life	MPC for ingestion ($\mu\text{Ci/ml}$)
U-238	4.51E9 y	3E-7	U-235	7.1E8 y	3E-7
Th-234	24.1 days	5E-6	Th-231	25.5 h	5E-5
Pa-234	1.17 min	3E-5	Pa-231	3.25E4 y	6E-9
U-234	2.47E5 y	3E-7	Ac-227	21.6 y	5E-9
Th-230	8.0E4 y	1E-7	Th-227	18.2 days	2E-6
Ra-226	1602 y	6E-8	Fr-223	22 min	---
Rn-222	3.821 days	---	Ra-223	11.43 days	1E-7
Po-218	3.05 min	---	Rn-219	4.0 sec	---
Pb-214	26.8 min	1E-4	Po-215	1.78 ms	---
Bi-214	19.7 min	3E-4	Pb-211	36.1 min	2E-4
Po-214	164 micro sec	---	Bi-211	2.15 min	---
Pb-210	21 y	1E-8	Tl-207	4.79 min	---
Bi-210	5.01 days	1E-5	Pb-207	stable	
Po-210	138.4 days	4E-8			
Pb-206	stable				

4. (15 points)

- (1) (5 points) In conventional reprocessing, uranium and plutonium are recovered, while all other nuclides in the original spent fuel are included in liquid high-level waste. To avoid damage of the organic solvent by high heat emission, reprocessing is usually made after some cooling time. A longer cooling time is considered advantageous. What is a potential disadvantage of having a long cooling time from the viewpoint of long-term safety for geologic disposal?
- (2) (5 points) For calculation of the decay heat power, the table below is often utilized. Why are the values of function F different for different fissile nuclides?

(3) (5 points) Calculate the decay heat power at 1 year after shutdown of an 1150 MW(e) LWR that operated for a year with the power history shown below and a thermal efficiency of 32%. Assume only U-235 fissions. Recoverable energy per fission for U-235 Q is 203 MeV.

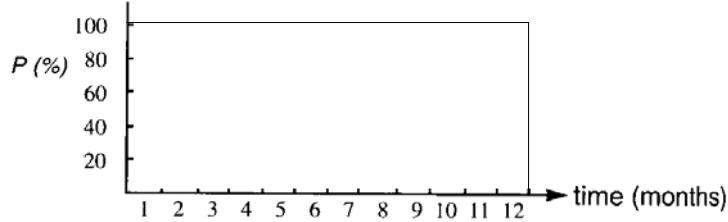

THE FUNCTION $F(t, \infty)$ FOR ^{235}U , ^{239}Pu , AND ^{238}U *

Time After Shutdown (s)	^{235}U		^{239}Pu		^{238}U	
	$F(t, \infty)$ (MeV/fission)	Uncertainty, 1σ (%)	$F(t, \infty)$ (MeV/fission)	Uncertainty, 1σ (%)	$F(t, \infty)$ (MeV/fission)	Uncertainty, 1σ (%)
1	12.31	3.3	10.27	5.6	14.19	12.0
10	9.494	2.0	8.243	4.2	10.29	9.5
10^2	6.198	1.8	5.685	4.2	6.217	5.9
10^3	3.796	1.8	3.516	4.4	3.598	4.9
10^4	1.908	1.7	1.727	4.8	1.777	4.4
10^5	0.9691	2.0	0.9421	5.0	0.9383	3.9
10^6	0.5509	2.0	0.5097	5.0	0.5171	3.9
10^7	0.2457	2.0	0.2282	5.0	0.2296	4.4
10^8	0.1165	2.0	0.08931	5.0	0.09280	5.0
10^9	0.05678	2.0	0.04195	5.0	0.04321	5.0

*From Ref. 43.

5. (15 points) The figure below shows a simplified model for partitioning and transmutation, discussed in the class. Assume that the system shown above is at a steady state, i.e., the mass flow in the system is identical for any cycle. Definitions of the parameters are the same as those given in the class notes. Assume that $C_1^o + C_p^o = C_1 + C_p = 1$.

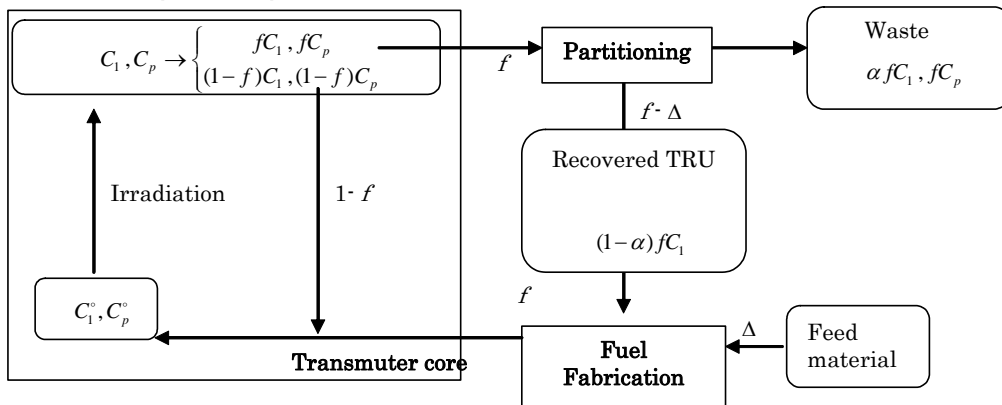

- (1) (5 points) Express the relationship between C_1 and C_1^o in terms of f . There is also the relationship between C_1 and C_1^o in terms of d , which is $C_1 = C_1^o \exp(-d)$. With these two relationships, express C_1^o in terms of f and d .
- (2) (5 points) Express the mass Δ added at the fuel fabrication in terms of α , f , and C_1 .
- (3) (5 points) Express the waste reduction ratio in terms of α , f , and d .