

Statics (E36)

The Second Practice Examination

Problem 1.

Draw Free-body diagrams for both members: AC and CB shown in Figure 1. Find the reaction forces at the point A and B. (20 points)

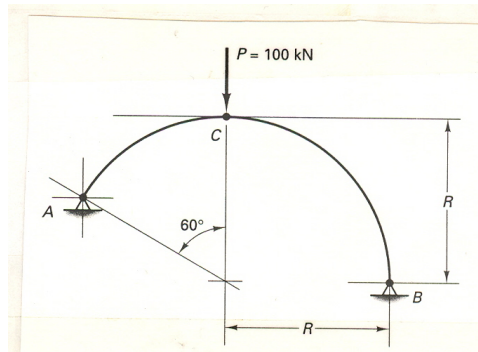

Figure 1: Curve Frame

Problem 2. Find the reaction force at point A, for the structure shown in Figure 2. (30 points)

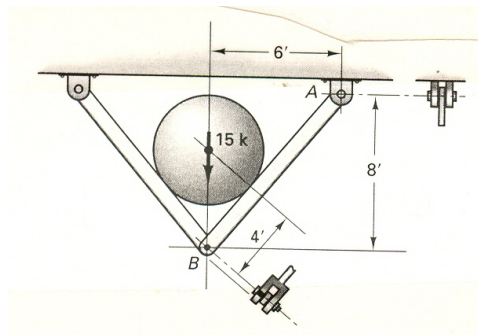

Figure 2: A tank supported by a two-bar frame

Problem 3

Find the centroid of the cross-section shown in Figure 3. (30 points)

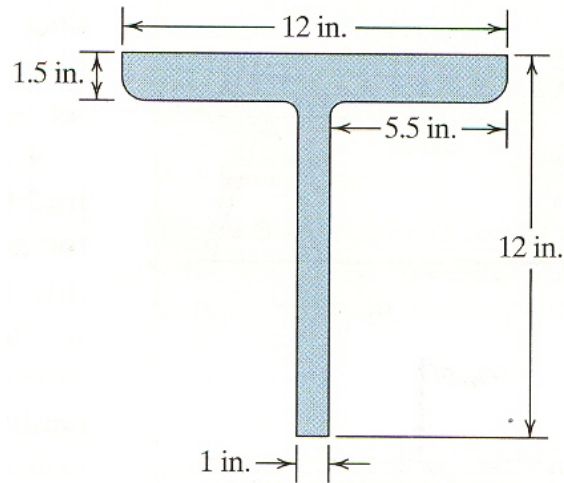

Figure 3: The cross section of a T-beam

Problem 4

Draw the shear and moment diagrams for the beam shown in Figure 4. (30 points)

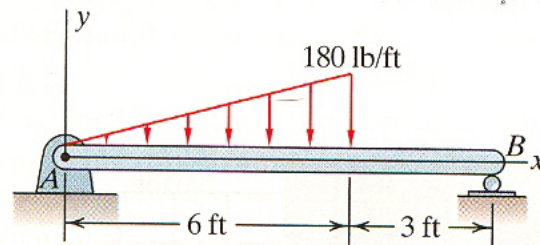

Figure 4: A simply supported beam with distributed load