

Name _____ Section # _____

SID # _____

Engineering 25
Spring Semester 2017
Final Examination

Read the instructions carefully and make sure you answer all parts of each question.

Print your full name on top of every page, even if it is unused.

Time Limit: 3 hours
Closed Book Exam

Problem 1 _____ /24

Problem 2 _____ /16

Problem 3 _____ /14

Problem 4 _____ /20

Problem 5 _____ /10

Problem 6 _____ /16

TOTAL EXAM SCORE _____

Problem #1 (24 points)

Shown below are two views (in 3rd angle projection) of three different objects. Add the missing views indicated in their correct location, orientation, and scale for an engineering drawing. You do not need to add dimensions, but some reasonable drawing accuracy is expected.

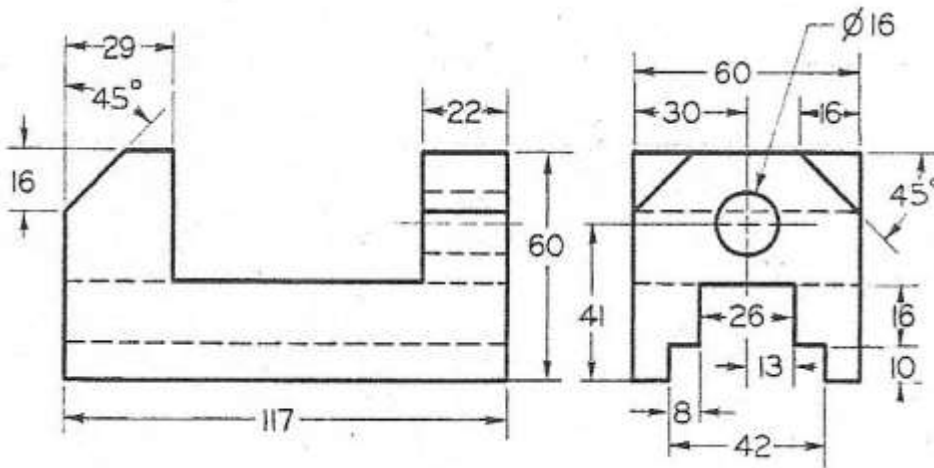

- a. Given front and right side views, add a top view.

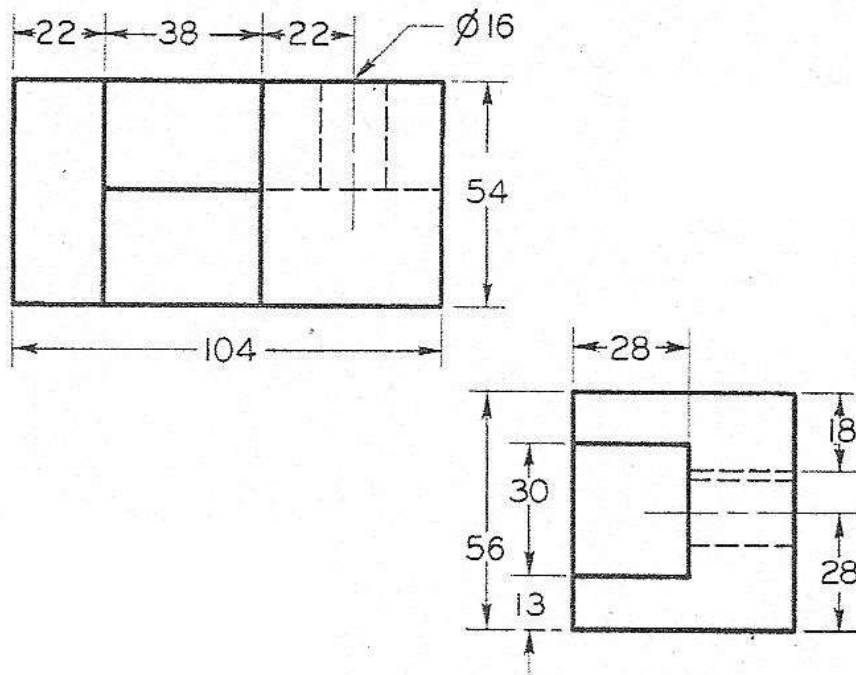

b. Given top and right side views, add a front view.

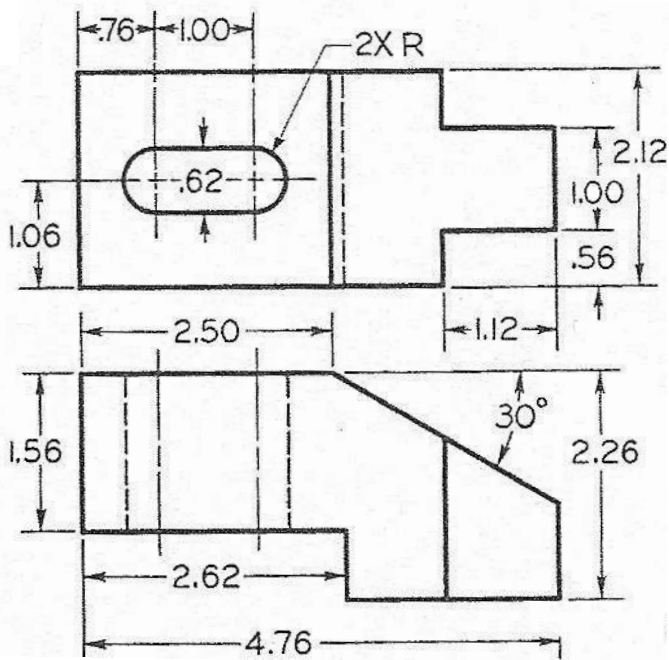

c. Given front and top views, add a right side view.

Problem 2 (16 points)

The front and right side views of two different objects are shown below (in 3rd angle projection). For each object, create a partial auxiliary view that shows the true shape of the inclined surface. You do not need to draw the entire object in the auxiliary view. The auxiliary must be in its correct location, orientation and scale for an engineering drawing. You do not need to add dimensions, but some reasonable drawing accuracy is expected. You do not need to show hidden lines. Do not erase your (lightweight) construction lines.

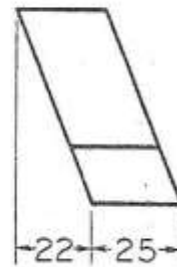
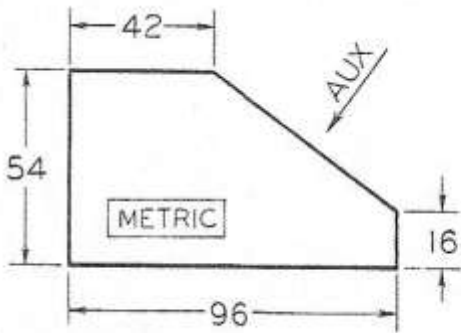

a)

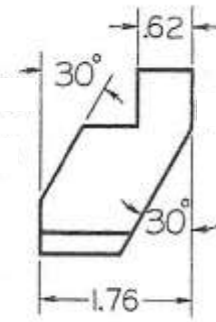
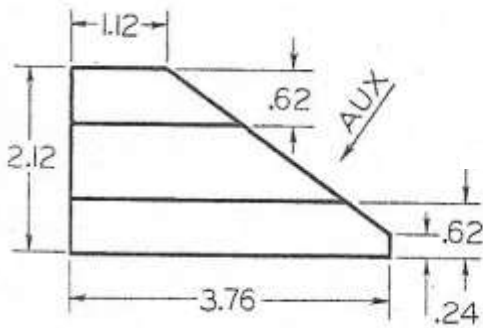

b)

Problem 3 (14 points)

For the object shown below, the front and an auxiliary views are shown (in 3rd angle projection). Add the top and left side views in their correct location, orientation, and scale for an engineering drawing. You will note that one of the surfaces on the object is an oblique surface, i.e. it cannot be shown in an edge view in any of the six standard (glass box) views. Add a second auxiliary view that shows the oblique surface in its true shape. You do not need to add dimensions, but some reasonable drawing accuracy is expected.

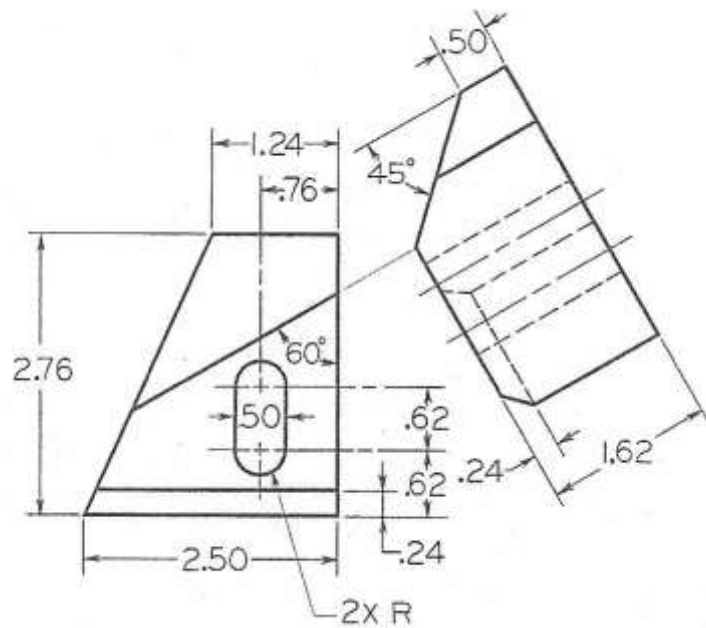

Problem 4 (20 points)

The figure below shows the front and top views of an object (in third angle projection).

- a) Using the cutting line A-A defined in the front view, add section view A-A as the right side view in its proper location, orientation and scale. You do not need to include hidden lines in the section view.
- b) Sketch an isometric pictorial that shows the object after it has been cut to reveal its interior detail. You do not need to include hidden lines, dimensions, or shading in the pictorial.

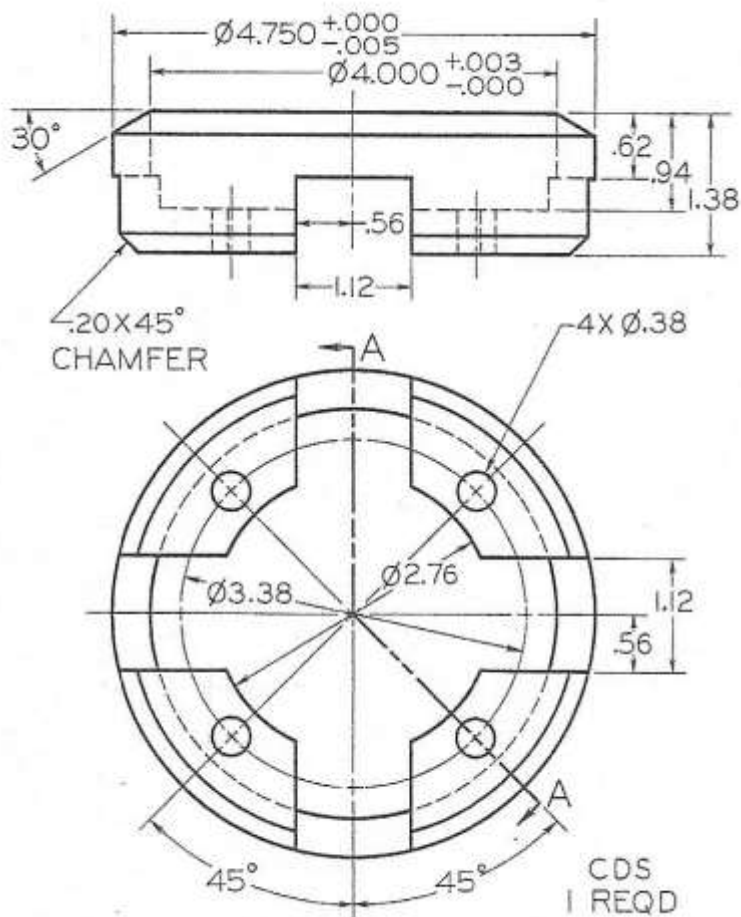

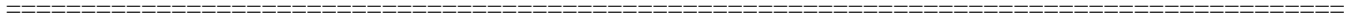

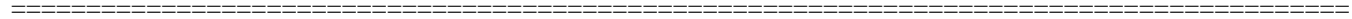

- 1.
- 2.
- 3.
- 4.
- 5.
- 6.
- 7.
- 8.
- 9.
- 10.
- 11.
- 12.
- 13.
- 14.
- 15.
- 16.
- 17.
- 18.
- 19.
- 20.

=====

Problem 6 (16 points)

When working with AutoCAD, provide an explanation and graphical examples of how the following commands are used to help aid in the construction or organization of a drawing:

1. LAYER
2. OSNAP (i.e. Object Snap)
3. UCS (i.e. User Coordinate System)
4. CONSTRAINTINFERR (i.e. Infer Constraints)

