

Midterm
Examination # 1,
Fall 2001
Answers

Problem 1 –Sketch Views

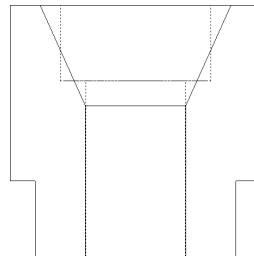
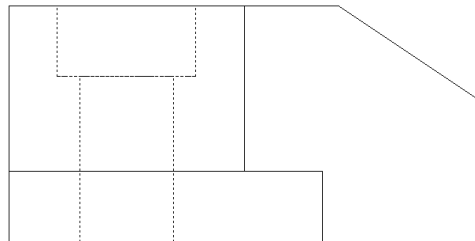
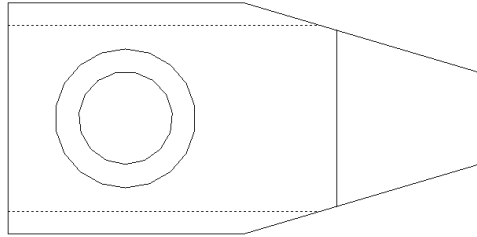

-Bottom?

-Isometric?

Problem 1 –Sketch Views

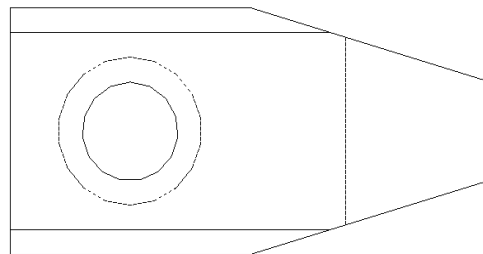
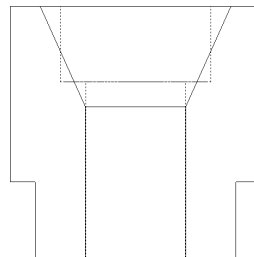
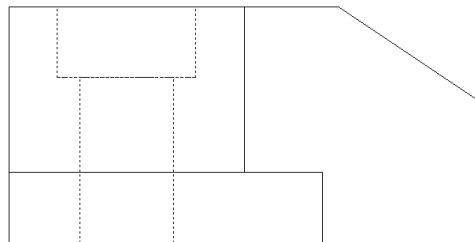
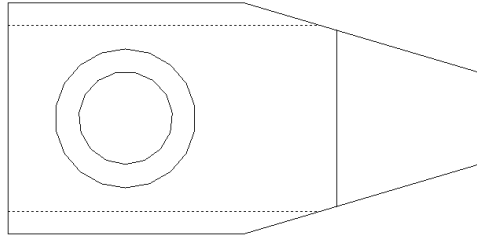

-Bottom View

Problem 1 –Sketch Views

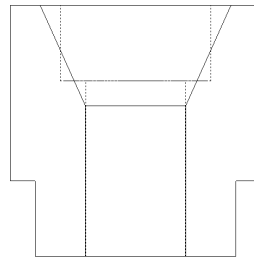
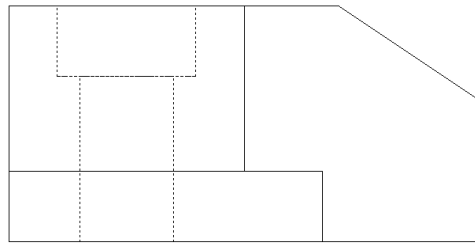
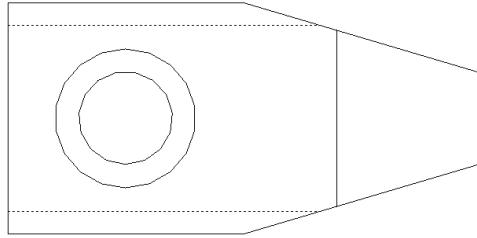

-Isometric

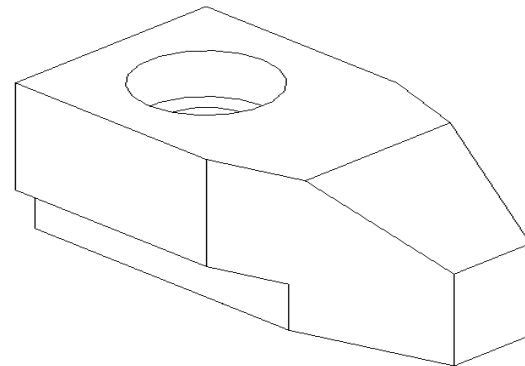

Problem 2 – Section views

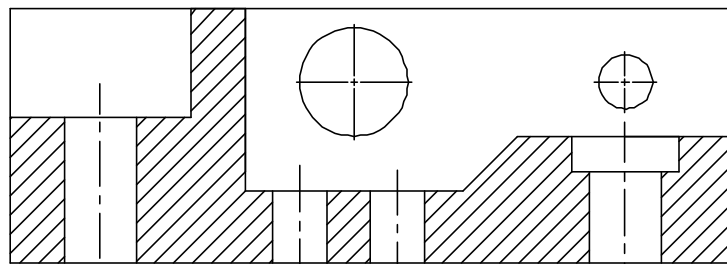
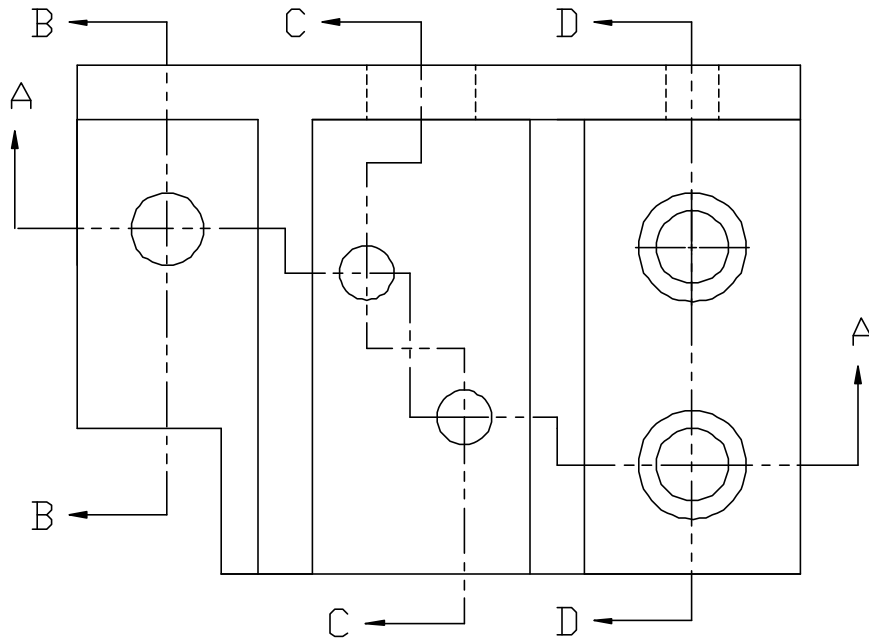

Section A-A

What do the other
Sections look like?

Problem 2 – Section views

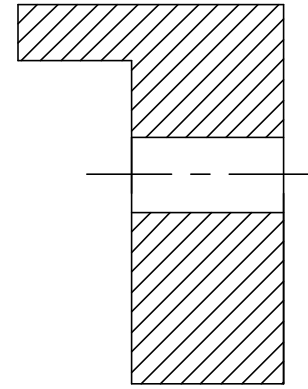
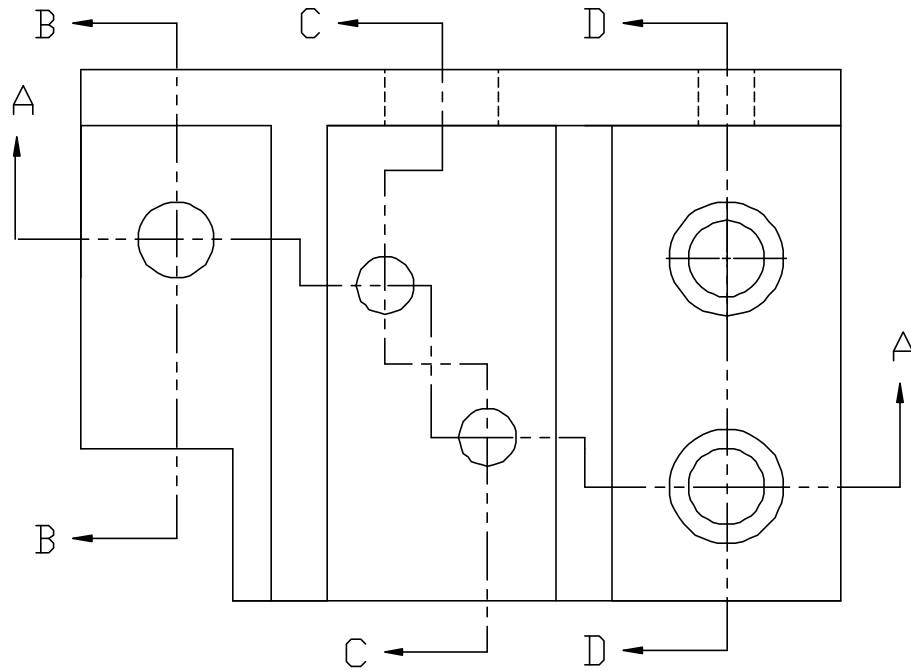

Section B-B

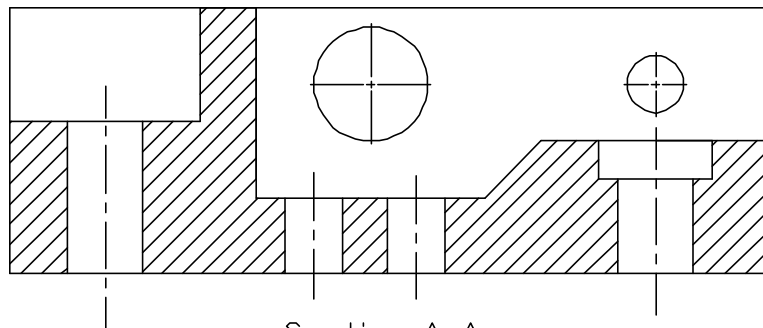

Section A-A

Problem 2 – Section views

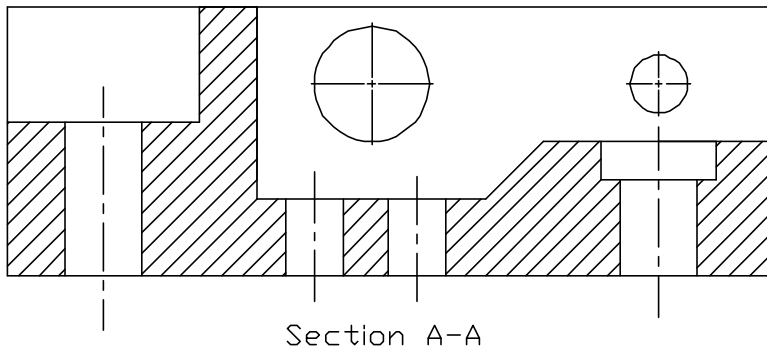
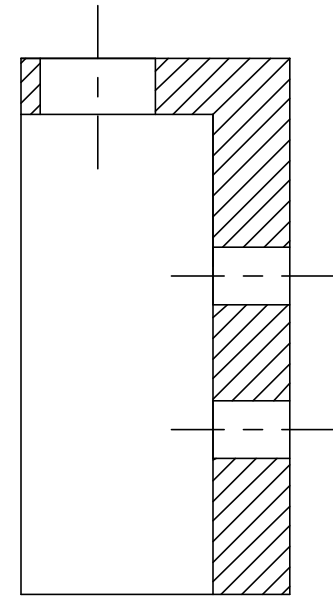
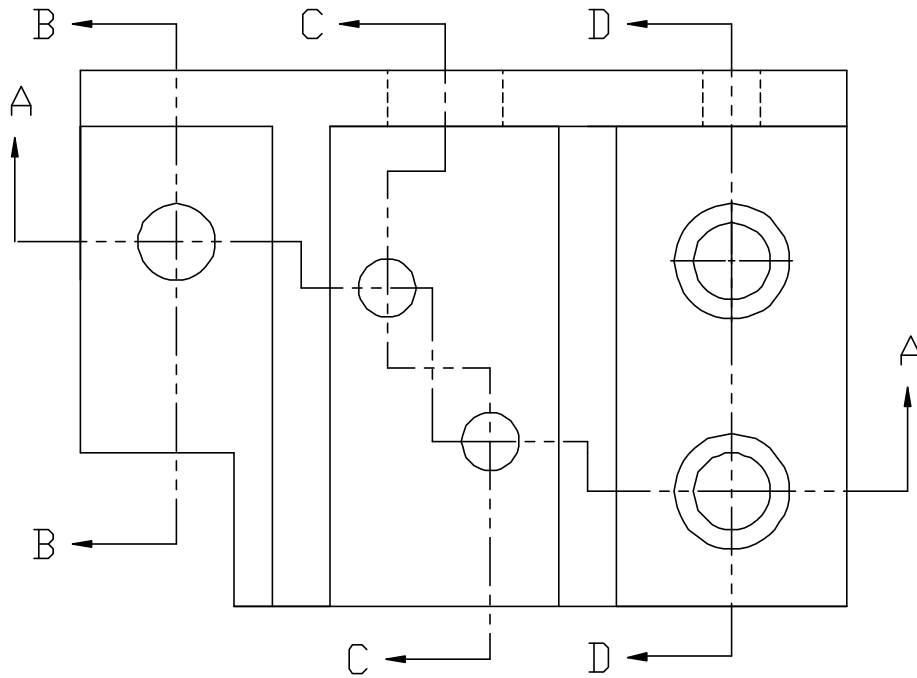

Problem 2 – Section views

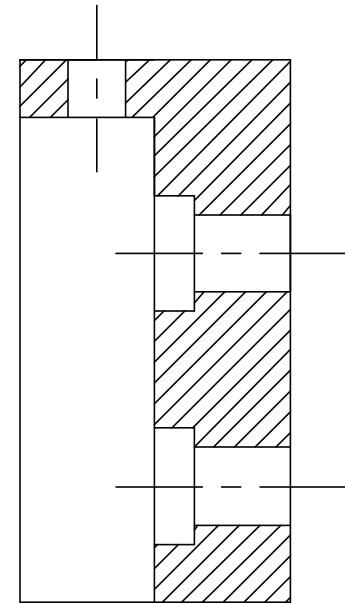
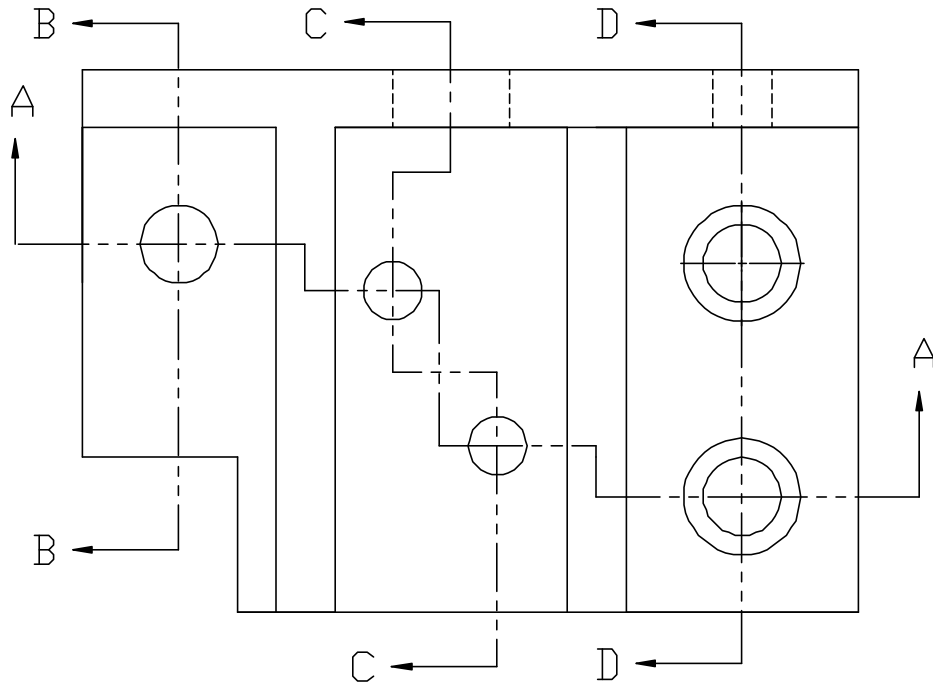

Section D-D

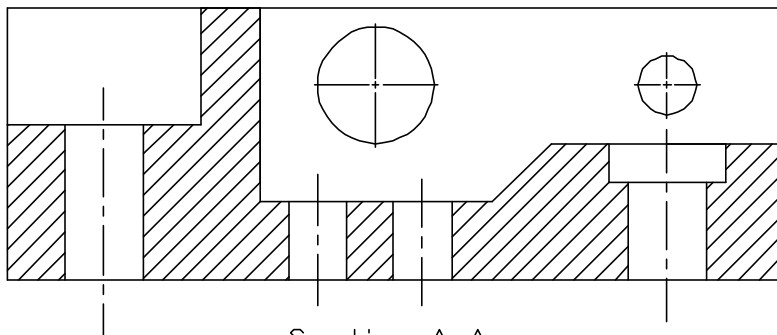

Section A-A

Problem 3 – What does this stand for?

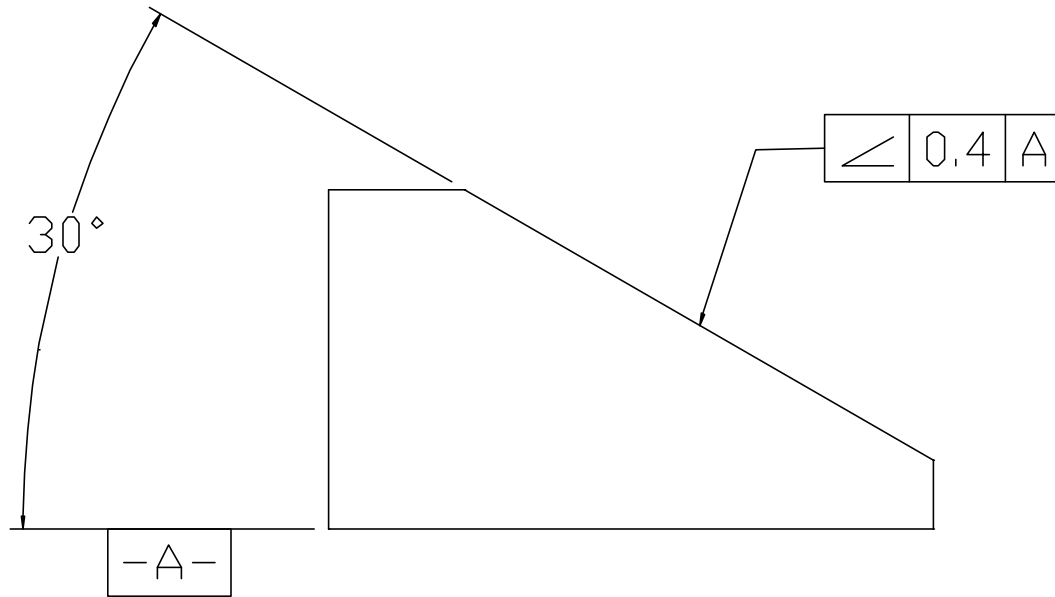

Problem 3 – It means this:

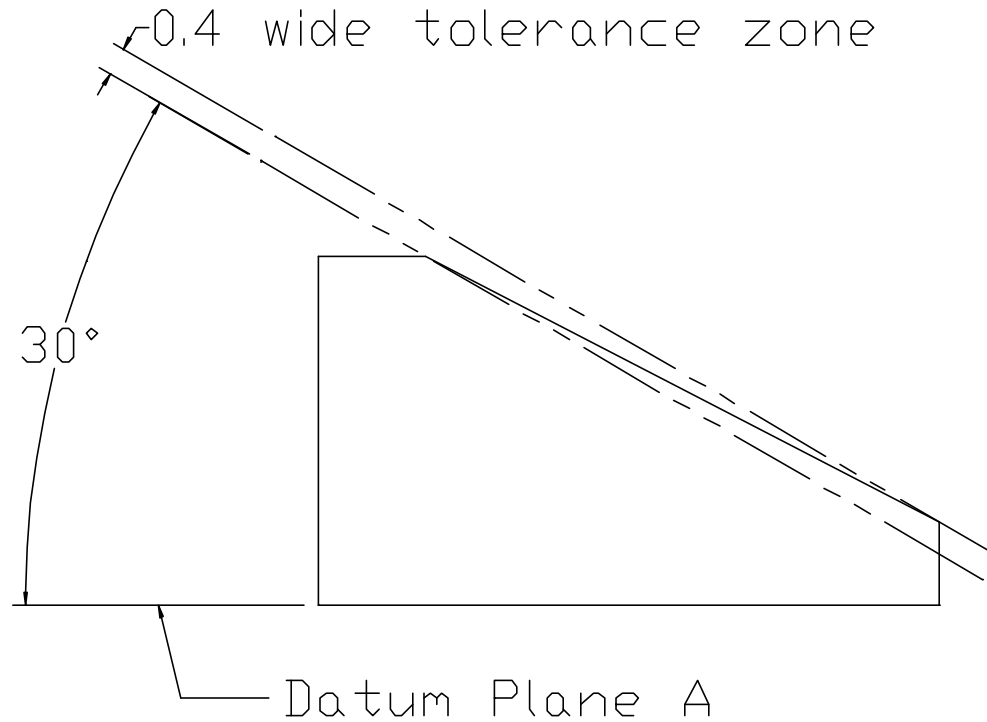

The surface must be within the specified tolerance of size and must lie between 2 parallel planes 0.4 apart which are inclined 30 degrees to datum plane A.

Problem 3 – What does this stand for?

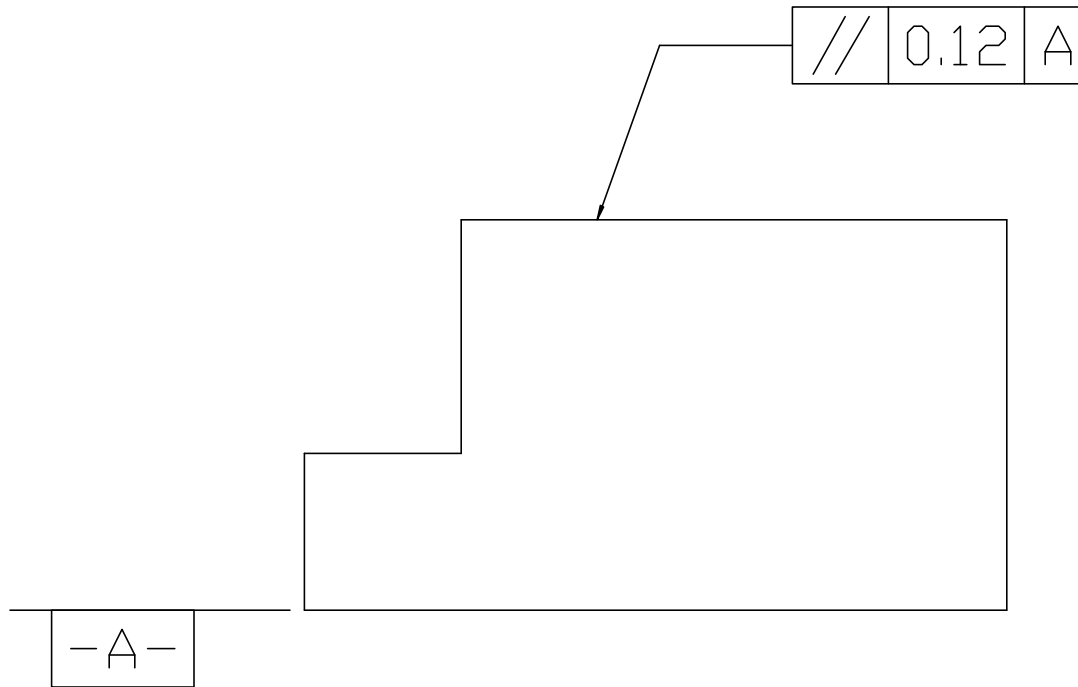

Problem 3 – It means this:

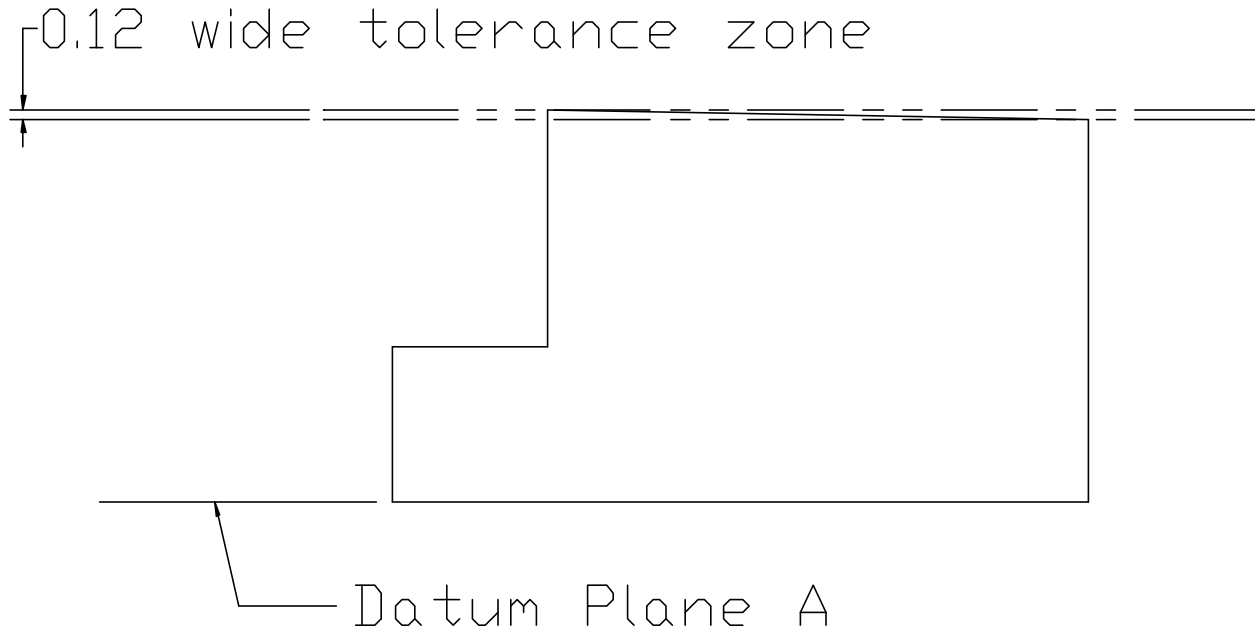

The surface must be within the specified tolerance of size and must lie between 2 parallel planes 0.12 apart which are parallel to datum plane A.

Problem 3 – What does this stand for?

n 15.89–16.00

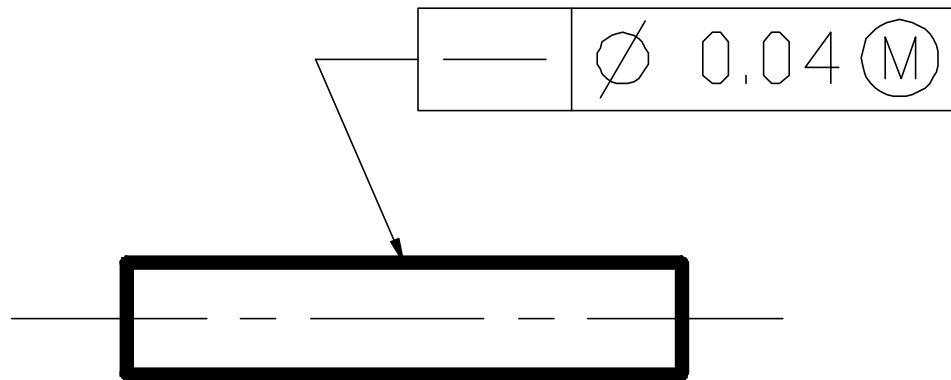

If part is manufactured to 16.00 diameter?

Problem 3 – It means this:

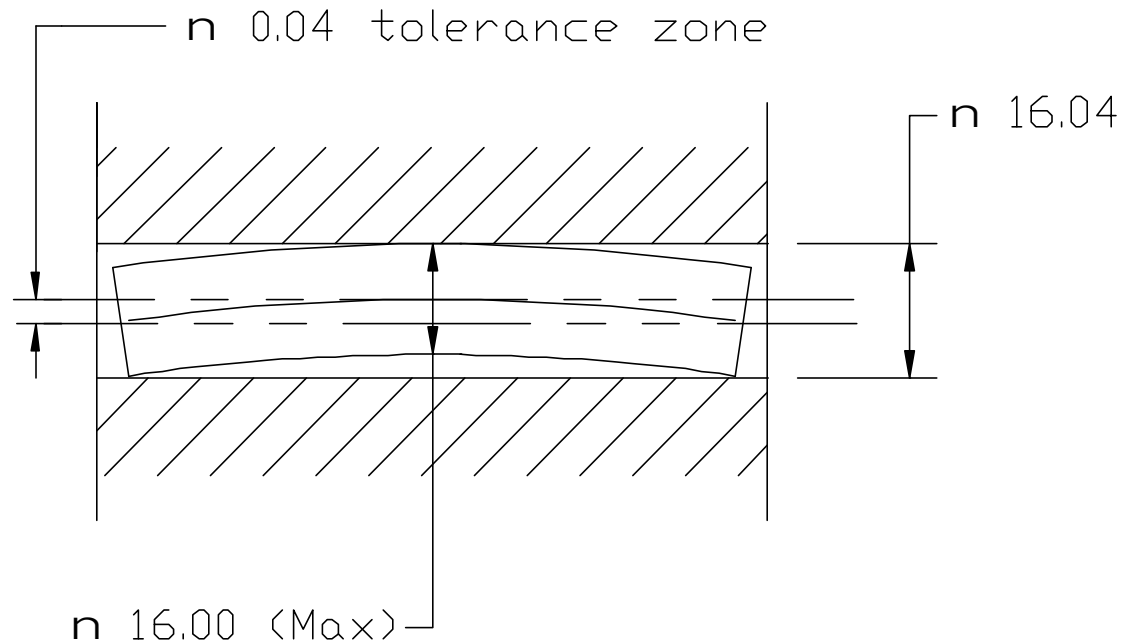

Each circular element of the figure must be within the specified tolerance of size. The centerline of the feature must lie within a cylindrical tolerance zone of 0.04 at MMC.

Problem 3 – What does this stand for?

n 15.89–16.00

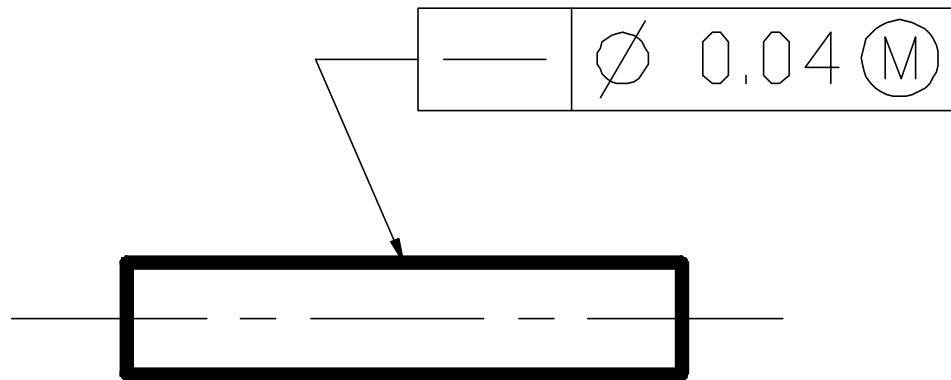

If part is manufactured to 15.89 diameter?

Problem 3 – It means this:

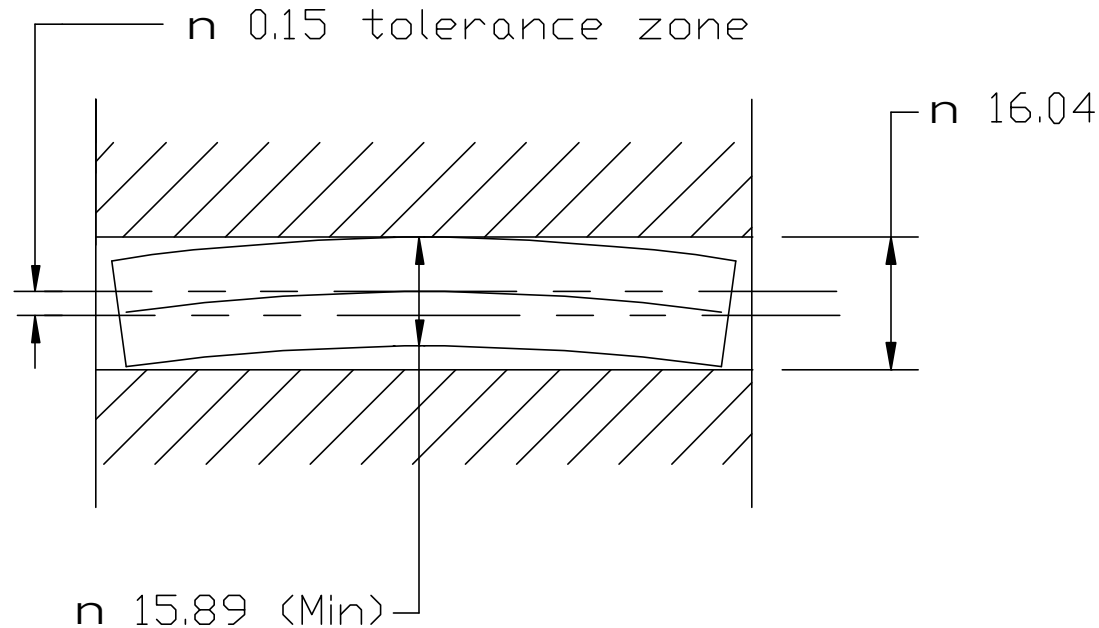

Each circular element of the figure must be within the specified tolerance of size. The allowed straightness tolerance increases equal to the amount feature departs from MMC. Here our tolerance zone increased from 0.04 to 0.15.

Problem 3 – What does this stand for?

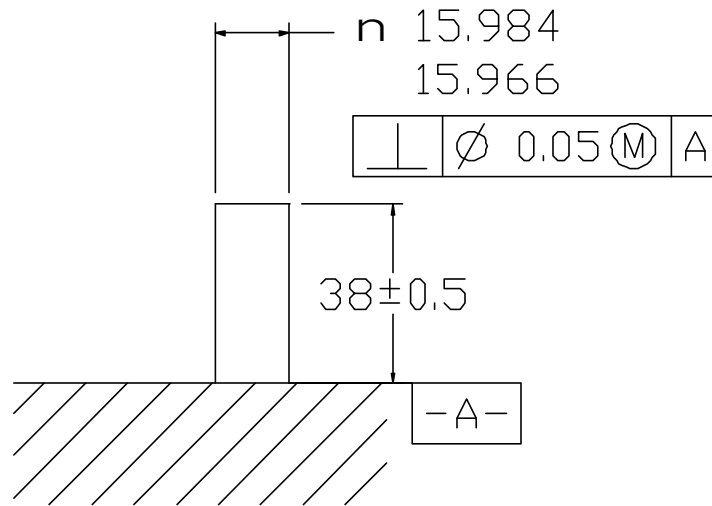

If part is manufactured to 15.966 diameter?

Problem 3 – It means this:

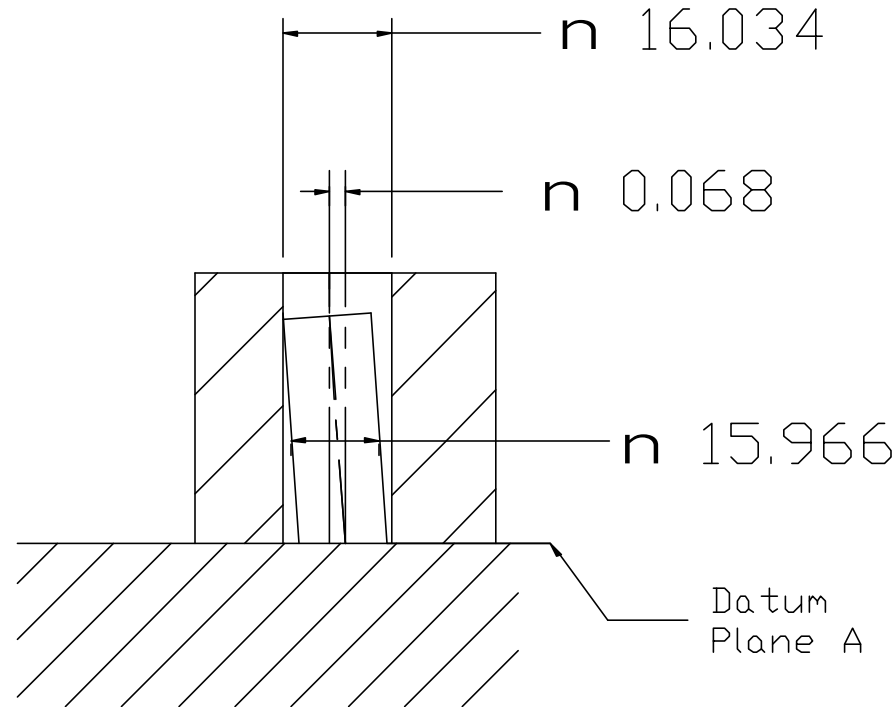

The Feature axis must be within the specified tolerance of location. Where the feature is at MMC the maximum perpendicularity tolerance is 0.05 diameter. Where the feature departs from its MMC size, an increase in perpendicularity is allowed which is equal to the amount of such departure.