

EECS140 Midterm 1
Spring 2016

Name _____

SID _____

Prob.	Score
1	/4
2	/8
3	/15
4	/12
5	/12
6	/8
Total	/59

1. [4] A single-pole amplifier has a low frequency gain magnitude of 10,000 and a gain magnitude of 10 at 10 MHz. What are the pole and unity gain frequencies?

$$f_p = 10\text{MHz}/(10\text{k}/10)=10\text{kHz};$$

$$f_u = 10\text{MHz}*10=100\text{MHz}$$

2. [8] You have made a new 3-terminal device from DNA and carbon nanotubes. With one terminal grounded, you determine that the output current in the device follows the equation $I_B = I_0 V_A^{3/2} \ln V_B$ in the region of operation with V_A and V_B between 2 and 10V.

a. Write an expression for the transconductance in terms of I_B and V_A
 $g_m = 3/2 I_B/V_A$

b. Write an expression for the output resistance in terms of I_B and V_B
 $g_o = I_0 V_A^{3/2} / V_B = I_B / (V_B * \ln(V_B)); r_o = (\ln(V_B) * V_B) / I_B$

c. Write an expression for the intrinsic gain in terms of the bias point

$$A_v = 3/2 \ln(V_B) V_B/V_A$$

d. To maximize the gain, where would you bias this device (what voltages)?

V_B large (10V) , V_A small (2V)

3. [15] You have an NMOS-input common source amplifier with a PMOS load. Both transistors are biased in saturation, and the quadratic model is appropriate. The magnitude of the gain is large (>100). You try two independent changes to the circuit: doubling the current by changing the bias voltages, and doubling the length of both transistors without changing anything else. How do these changes affect the operating point and performance of the amplifier?

Process specs $\mu_n C_{ox} = 200 \mu A/V^2$, $\mu_p C_{ox} = 100 \mu A/V^2$, $\lambda = 1/(10V)(L_{min}/L)$, $-V_{tp} = V_{tn} = 0.5V$, $V_{DD} = 2V$, $L_{min} = 1 \mu m$, $C_{ox} = 5 fF/\mu m^2$, $C'_{ol} = 0.5 fF/\mu m$.

	I_D	L	V_{ov}	g_m	R_o	A_v	ω_p	ω_u	C_{in}
Case 1	2	1	$\sqrt{2}$	$\sqrt{2}$	$1/2$	$1/\sqrt{2}$	2	$\sqrt{2}$	$1/\sqrt{2}$
Case 2	$1/2$	2	1	$1/2$	4	2	$1/4$	$1/2$	2

4. [12] Fill in the following table for a single-pole amplifier. Each row is a different amplifier.

g_m	R_o	C_L	A_{v0}	ω_p	ω_u
100mS	100	10 p	10	1G	10 G rad/s
1mS	1M Ω	1pF	1000	1M rad/s	1G

5. [12] You measure the drain current of one NMOS and one PMOS transistor that you intend to use in a common source amplifier. You bias the PMOS source at 10V, the gate at 5V, and sweep the drain voltage. You bias the NMOS source at ground, and the gate at 2 and 2.1V (two different curves), and sweep the drain voltage. The resulting curves are shown below.

- a. Estimate the PMOS output resistance r_{op}

$$10V/1mA = 10k$$

- b. Estimate the magnitude of the PMOS threshold voltage

$$|V_{dsat}| = 2V = |V_{GS}| - |V_{tp}| = 5 - |V_{tp}| \rightarrow V_{tp} = -3V, |V_{tp}| = 3V$$

- c. Estimate g_m of the NMOS transistor when $V_{GS}=2V$ and $V_{DS}=5V$

$$\Delta I / \Delta V_{gs} = 0.5mA / 0.1V = 5mS$$

- d. Estimate the gain of an NMOS-input common source amplifier made with these two transistors under similar bias conditions to those used below.

$$-G_m R_o = -5mS (10k / 2) = -25$$

- e. Estimate the output swing of the amplifier (V_{min} to V_{max}). Try to express V_{min} to a precision of one tenth of a volt.

1.2 to 8V

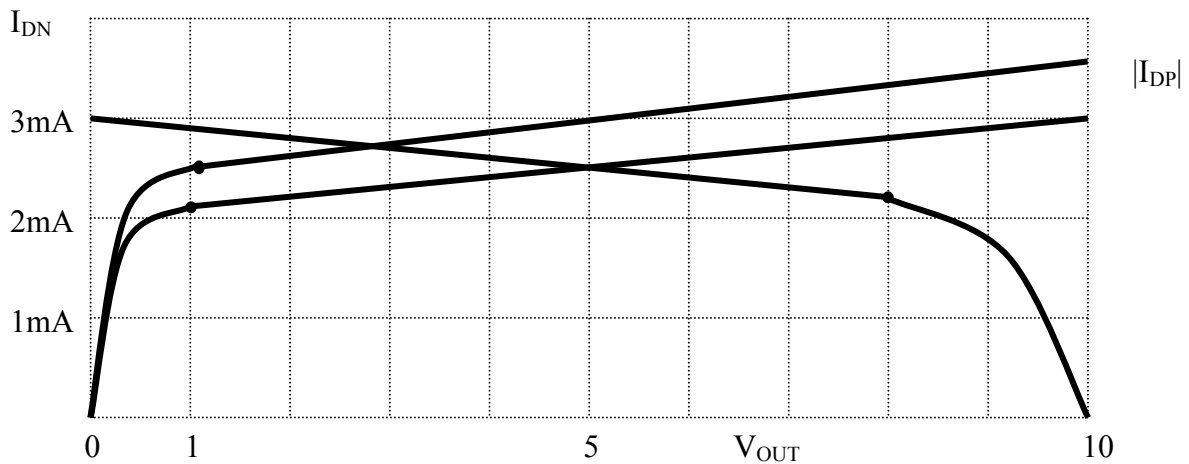

6. [8] The four transistors shown below are all biased at a current of 1uA. The NMOS device M1 is in sub-threshold, with $V_{GS}-V_t=-200\text{mV}$, and $n=1.5$. The NMOS device M2 is velocity saturated with $V_{GS}-V_t=100\text{mV}$. The NMOS device M3 is in saturation, with a channel field of approximately $0.1\text{V}/\mu\text{m}$ and $V_{GS}-V_t=100\text{mV}$.
- A) Approximately what change in V_{BE} will cause the collector current to increase by a factor of 10?
- B) Approximately what change in V_{GS1} will cause the drain current in M1 to increase by a factor of 10?
- C) Approximately what change in V_{GS2} will cause the drain current in M2 to increase by a factor of 10?
- D) Approximately what change in V_{GS3} will cause the drain current in M3 to increase by a factor of 10?

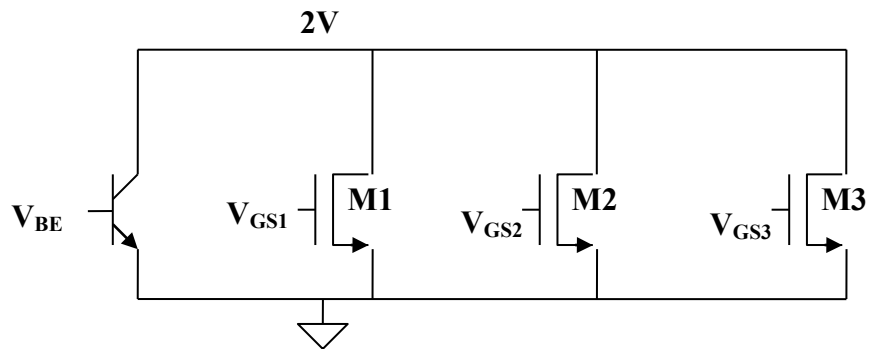

$\Delta V_{BE} = 60\text{mV}$	$\Delta V_{GS1} = 1.5 * 60\text{mV} = 90\text{mV}$	$\Delta V_{GS2} = 1\text{V} *$	$\Delta V_{GS3} = 0.32\text{V} **$
-------------------------------	--	--------------------------------	------------------------------------

* Really, V_{ov} goes up by 10x to 1V, so V_{GS} only needs to go up by another 900mV.

** Really, V_{ov} goes up by $\ln(10)$ x to 0.32V, so V_{GS} only needs to go up by 220mV (200mV was fine if you showed that you got there by approximating $\ln(10) \sim 3$).