

Chemistry 3A Midterm 2

Student name: ANSWERS

Student signature: _____

Problem 1	_____	(18 pts)
Problem 2	_____	(30 pts)
Problem 3	_____	(32 pts)
Problem 4	_____	(18 pts)
Problem 5	_____	(16 pts)
Problem 6	_____	(20 pts)
Problem 7	_____	(16 pts)
Total Points	_____	(150 pts)

**No Calculators Allowed
No Molecular Models Allowed
Be Sure Your Exam has 10 Pages**

1. There will be NO partial credit for this problem. Avoid careless errors by checking over your answers. (18 pts)

A. Provide a systematic name for the following compounds (include R/S when appropriate). Use common nomenclature for any branched substituents.

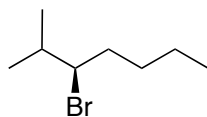

(*R*)-3-bromo-2-methylheptane

OR

(*R*)-5-bromo-6-methylheptane

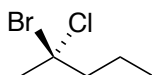

(*R*)-2-bromo-2-chloropentane

OR

(*R*)-4-bromo-4-chloropentane

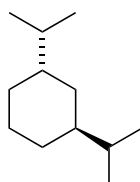

(1*S*,3*S*)-1,3-diisopropylcyclohexane

B. Draw a structure for each of the following names. For cycloalkanes use flat rings.

➤ (*1R,2S*)-1-iodo-2-tert-butylcyclohexane

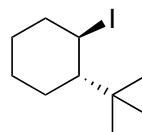

➤ Draw a Fischer projection of (*S*)-1,2,4-trichlorobutane

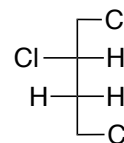

➤ The Newman projection shown below is looking down the C-H bond of the stereocenter in (*S*)-1-bromo-2-chloro-3-fluoro-3-methylbutane. Finish drawing the Newman projection of this molecule.

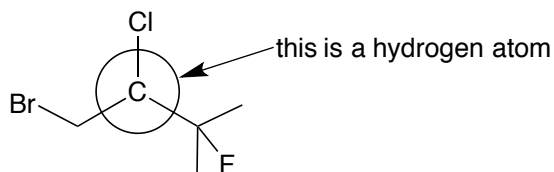

2. Predict all of the possible organic product(s) from the following reactions. Where relevant, show all stereoisomers. Pay particular attention to any information given in the product boxes. Each redundant or wrong answer within a box cancels one correct in the same box. (30 pts)

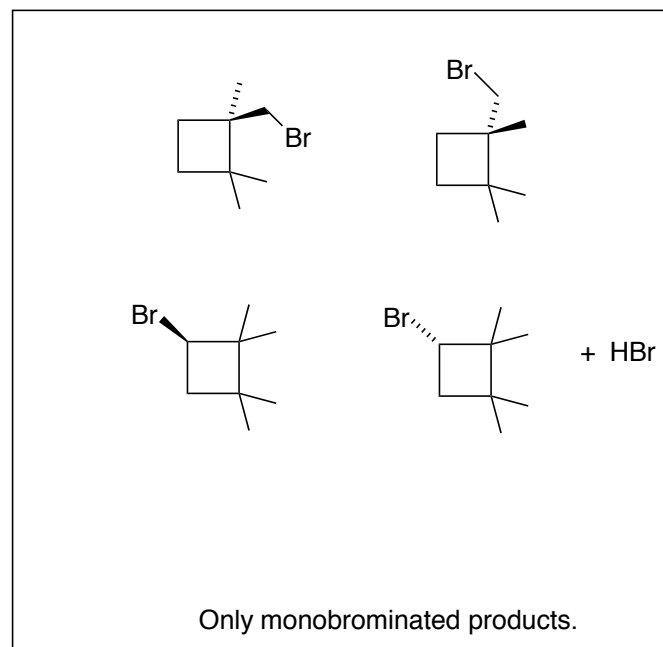
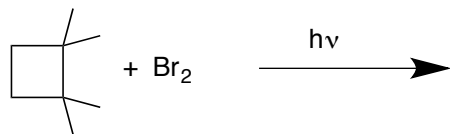
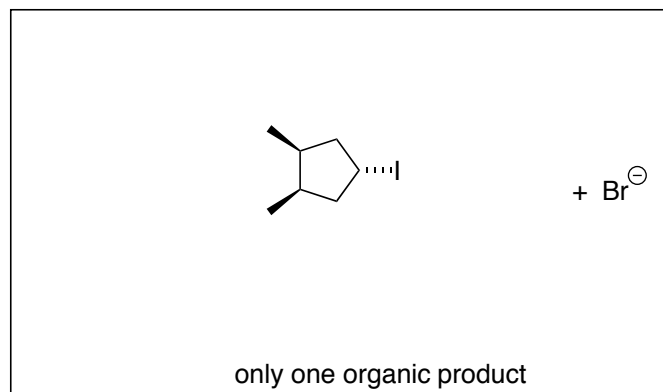
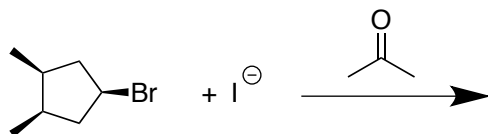
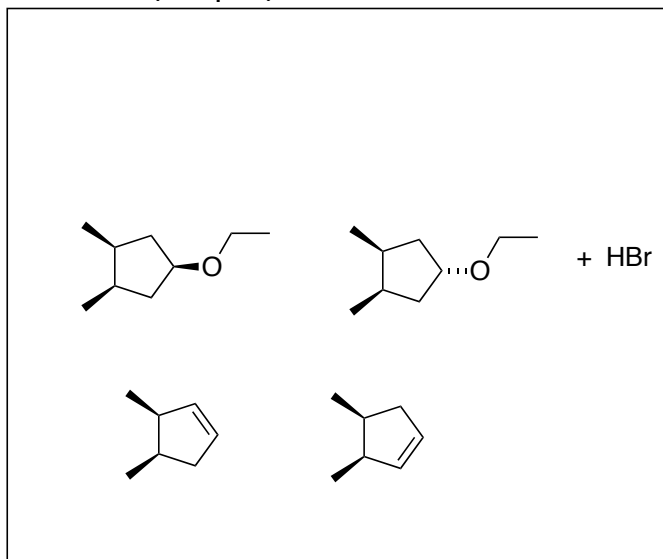
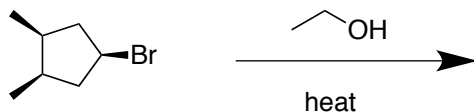

Continued on next page

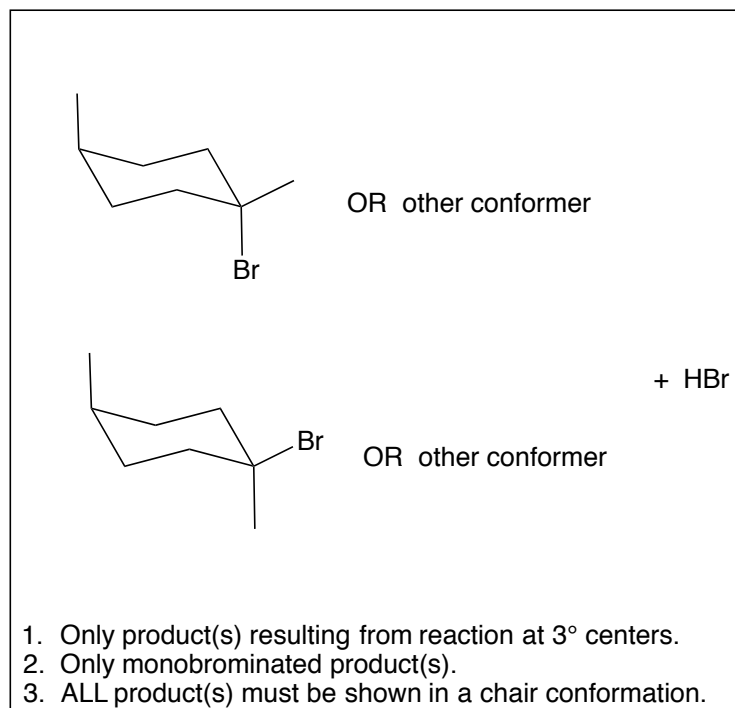
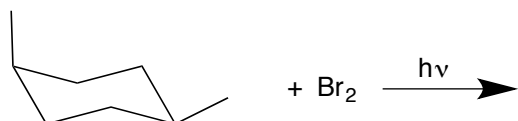
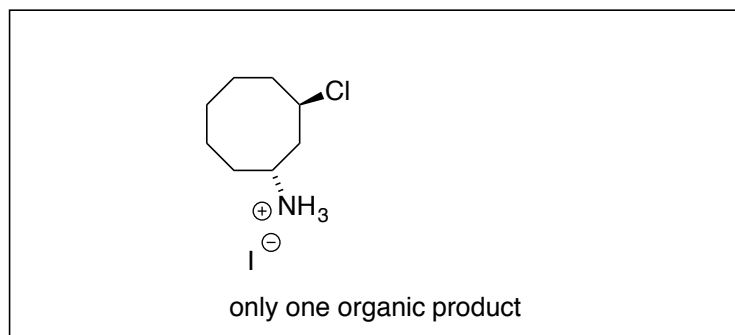
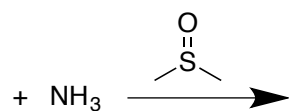
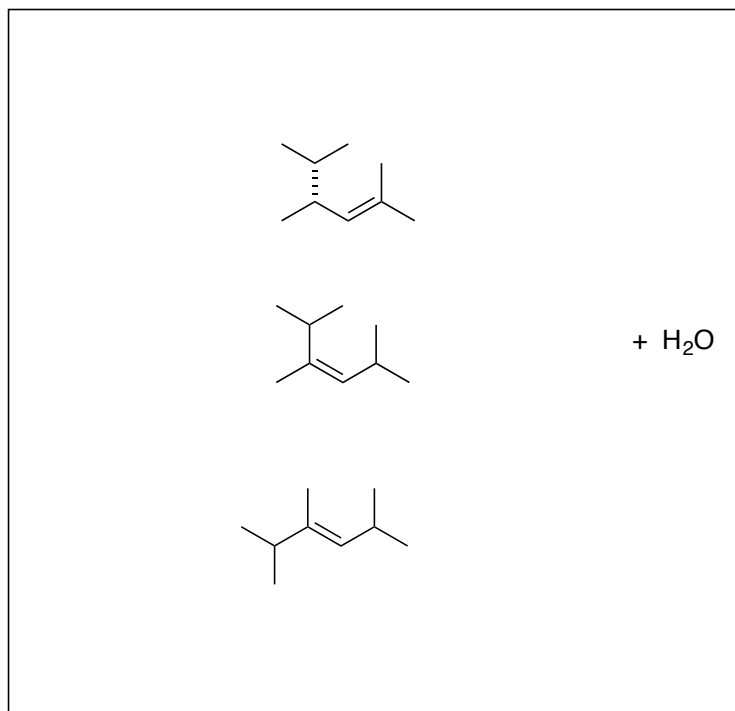
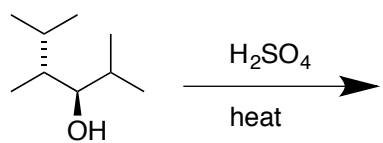

3. Write logical arrow-pushing mechanisms for the following reactions. Be sure that your mechanism accounts for all products shown. (32 pts)

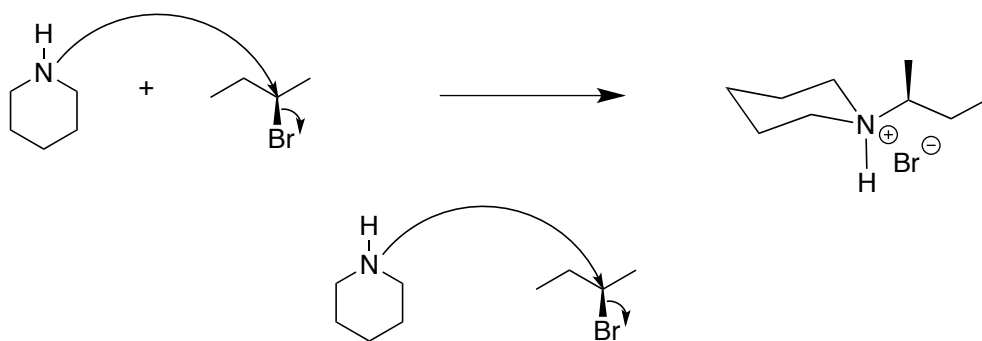
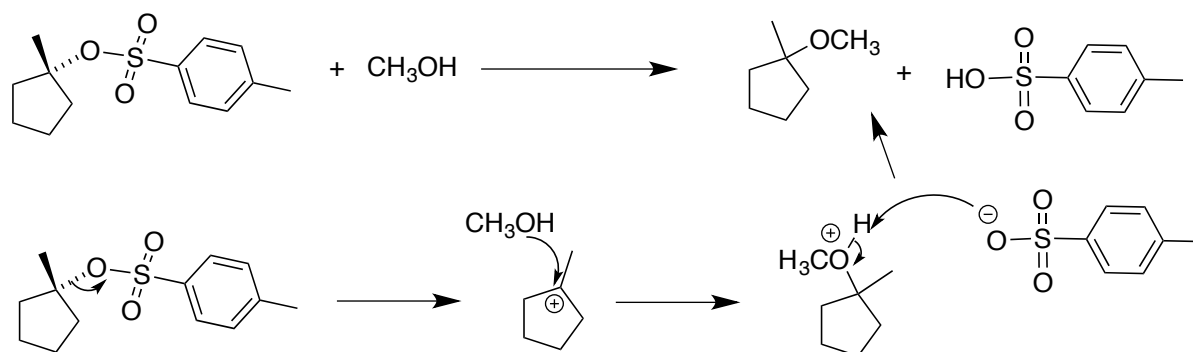

Continued on next page

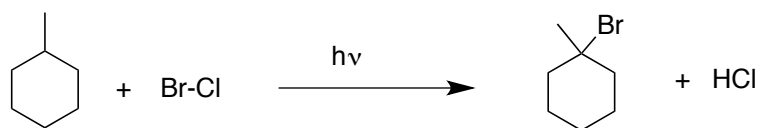

Hint: Neither product is formed from a termination reaction.

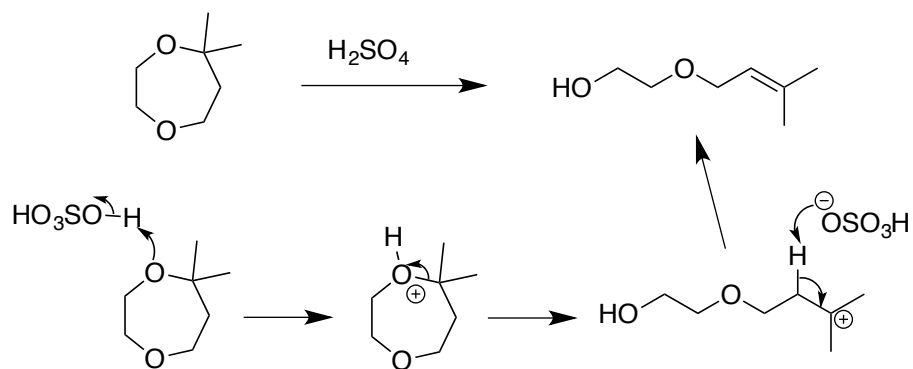
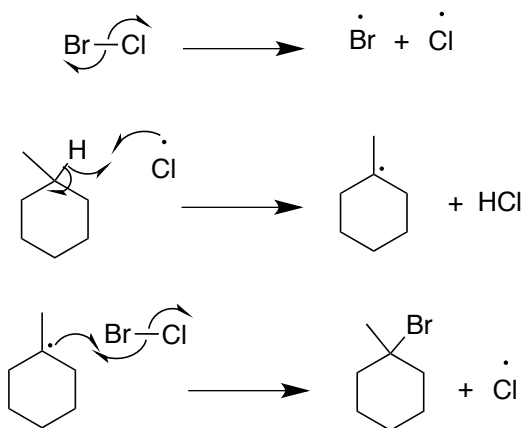

4. (18 pts)

A. Is the following reaction exothermic or endothermic? Circle one. Provide a brief explanation that justifies your choice (no credit if there is no explanation).

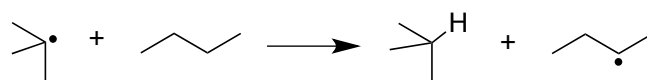

Exothermic

Endothermic

Brief explanation:

The tertiary radical on the left is more stable than the secondary radical on the right. Therefore, the reaction will be endothermic.

B. Based on YOUR answer to Part A, draw a transition state picture for this reaction that is consistent with Hammond's postulate. Use dotted lines to represent bond-breaking and/or bond-making and be sure that the lengths of the dotted lines are easily distinguishable.

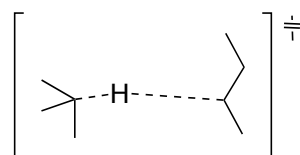

C. Is the transition state picture you drew in Part B considered an early or late transition state? Circle one.

Early

Late

D. Is the reaction in Part A considered to be: Circle one

- An initiation step
- A propagation step
- A termination step
- A terminator step

E. Write a logical arrow-pushing mechanism for the reaction shown in Part A.

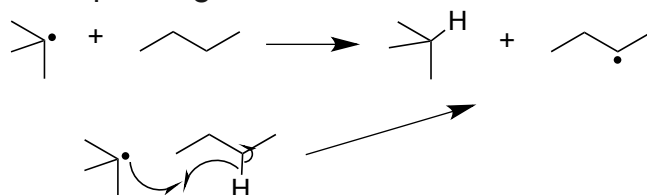

5. (16 pts)

A. Compound A shown below is chiral. Demonstrate how replacing ONE hydrogen atom in Compound A with a methyl group can lead to an achiral molecule (you must attach the methyl group using a wedge or a dash to indicate relative orientation of the group). Draw the structure of this molecule.

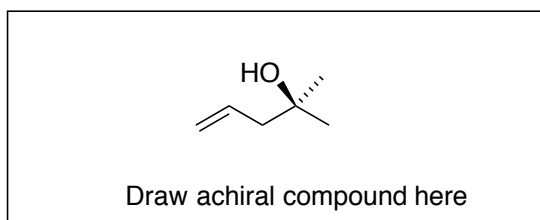
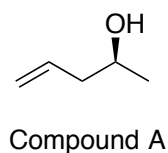

B. Demonstrate how replacing ONE hydrogen atom with a methyl group in the compound shown below can lead to a new compound that has a total of 4 stereoisomers. Draw all 4 stereoisomers.

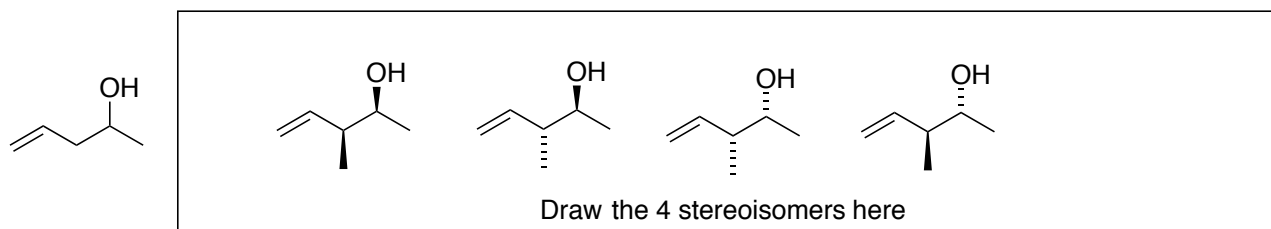

C. The compound shown below is achiral. Create a new achiral compound by replacing ONE of the hydrogen atoms on ONE of the carbons labeled 1-5 with a substituent with the formula C_4H_9 (you must attach the substituent using a wedge or a dash to indicate relative orientation of the group).

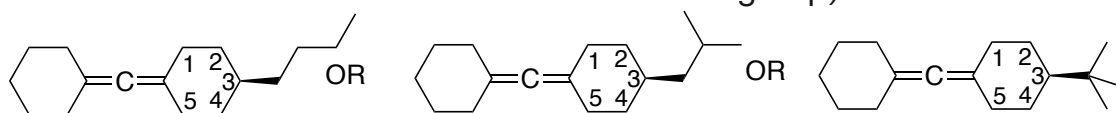

D. The compound shown below is achiral. Create a chiral compound by replacing ONE of the hydrogen atoms on ONE of the carbons labeled 1-5 with a substituent with the formula C_4H_9 (you must attach the substituent using a wedge or a dash to indicate relative orientation of the group).

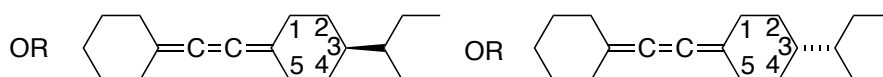
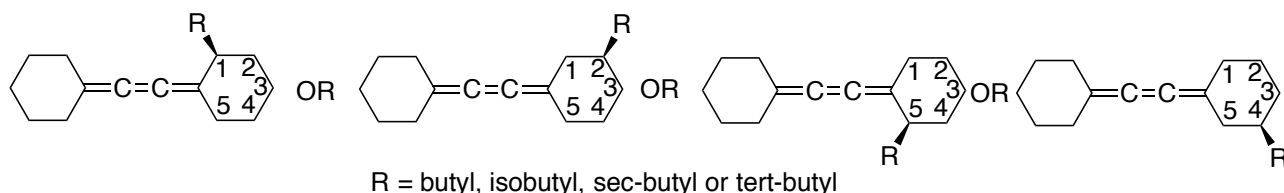

6. (20 points)

A. For each pair of molecules listed use one term that best describes their relationship to one another. Use the abbreviations for the terms shown below.

The terms are: Identical (I), Diastereomer (D), Enantiomer (E), None of These (N)

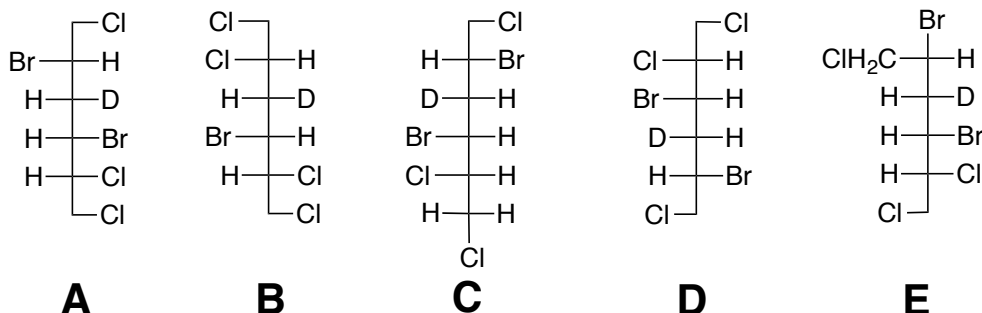

A and B: N A and C: E A and D: I A and E: D

B. The specific rotation of a compound was reported as shown below. There is an important piece of information missing. What is it?

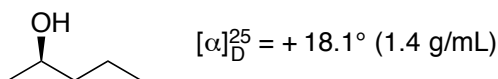

The solvent used to dissolve the chiral compound is not mentioned.

C. The enantiomeric excess of a solution is 92%. How much of each enantiomer is present? To receive credit you must show your work.

The remaining 8% must be a 50:50 mixture of both enantiomers. Therefore, there is 96% (92% + 4%) of one enantiomer and 4% of the other enantiomer.

D. When dissolved in ethanol and placed in a polarimeter the compound shown below gave an optical rotation of 0°. Explain this result using terms and concepts we have discussed in class. It is not enough to simply mention words like racemic or achiral. You must explain why it is valid to use such terminology in this particular situation. Keep your answer within the space below (do not write on the back of this page).

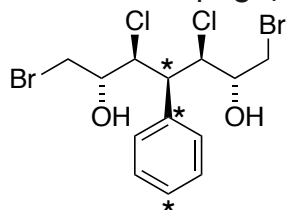

*The molecule is achiral due to a plane of symmetry that is defined by the * shown on the molecule above. If the molecule is achiral then it will be optically inactive, that is, there will be no net rotation of plane-polarized light.*

7. (16 points)

A. Explain the difference in relative rates between the two nucleophiles shown below. Your explanation must include words AND drawings to receive any credit.

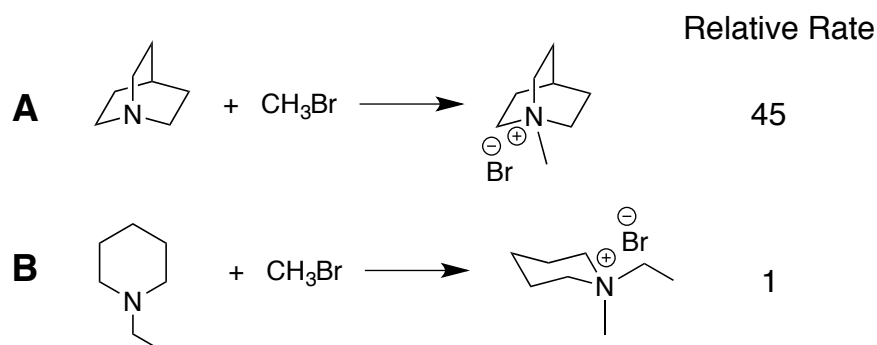

Explanation:

As seen in the pictures below, for Compound A there are no other conformers that can be drawn due to the rigid nature of this bicyclic structure. In Compound B, the ethyl group can rotate about the C-N bond, which in one conformer puts the methyl group close to the lone pair of electrons. This is a more hindered situation and will slow down the reaction of Compound B with bromomethane relative to Compound A.

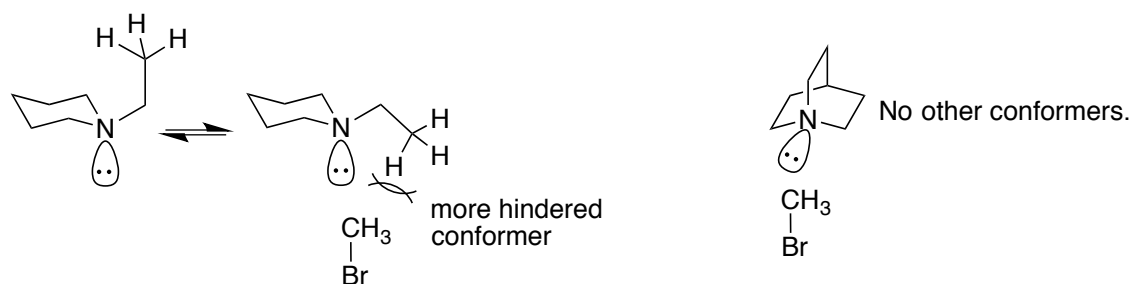

B. For reaction A shown in Part A, draw an accurate transition state picture, including any relevant geometry associated with the transition state. Assume the reaction is exothermic.

