

Midterm 1
EE40
Fall 2012

NAME: _____

Instructions

Read all of the instructions and all of the questions before beginning the exam.

There are 4 problems in this exam. The total score is 100 points. Points are given next to each problem to help you allocate time. Do not spend all your time on one problem.

Unless otherwise noted on a particular problem, you must show your work in the space provided, on the back of the exam pages or in the extra pages provided at the back of the exam.

Draw a BOX or a CIRCLE around your answers to each problem.

Be sure to provide units where necessary.

GOOD LUCK!

PROBLEM	POINTS	MAX
1		12.5
2		35
3		27.5
4		25

“Everything will turn out right... the world is built on that.”
— Mikhail Bulgakov, *The Master and Margarita*

Problem 1 Warm-up (12.5 points)

a) Consider the unknown, linear circuit below. Within the box are contained dependent sources, resistors and independent sources.

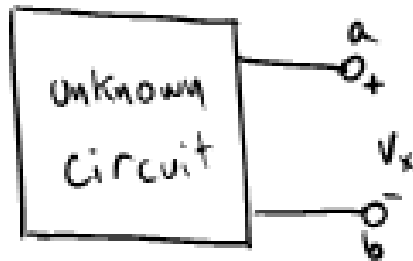

We measure the voltage V_x before the box is attached to anything else and find $V_x = 1$ V.

We then connect the box to this circuit (where $R_S = 1$ k Ω and $V_S = 2$ V):

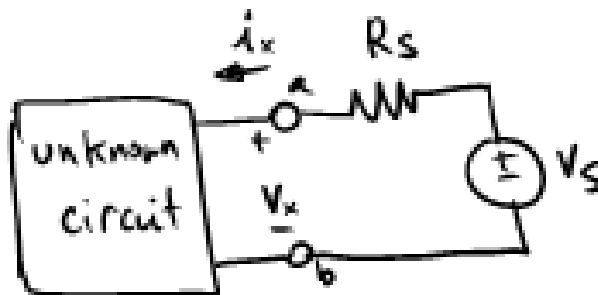

and measure $i_x = 1$ mA.

What is the Thevenin equivalent R_{TH} and V_{TH} for the circuit in the box?

$R_{TH} =$	$V_{TH} =$
------------	------------

“Won't somebody please think of the children!?!”
 —Helen Lovejoy, *The Simpsons*

Problem 2 Nodal (X points)

Provide a solution to the circuit below USING NODAL analysis. Use the node numbers and labels provided.

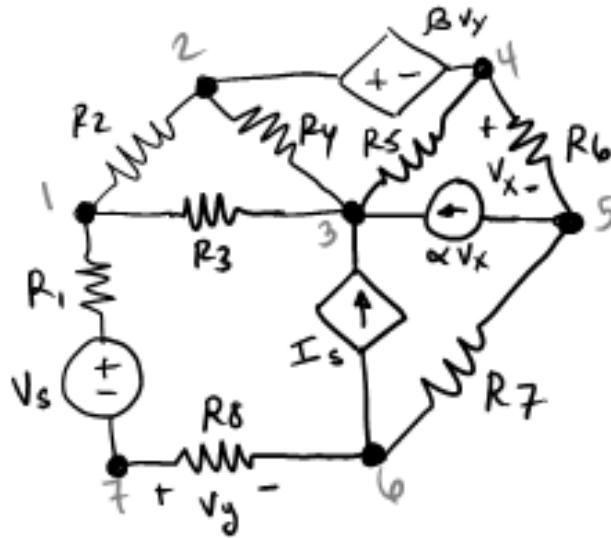

In the box below, provide your answer with equations in this form or lose points ($v1$ refers to the voltage at node 1, etc):

$$\underline{\quad} v1 + \underline{\quad} v2 + \dots + \underline{\quad} vn = \underline{\quad}$$

...

Solution:

“If they can get you asking the wrong questions, they don't have to worry about answers.”
 — Thomas Pynchon, *Gravity's Rainbow*

Problem 3 Mesh (X points)

Provide a solution to the circuit below USING MESH analysis. Use the mesh variables and labels provided.

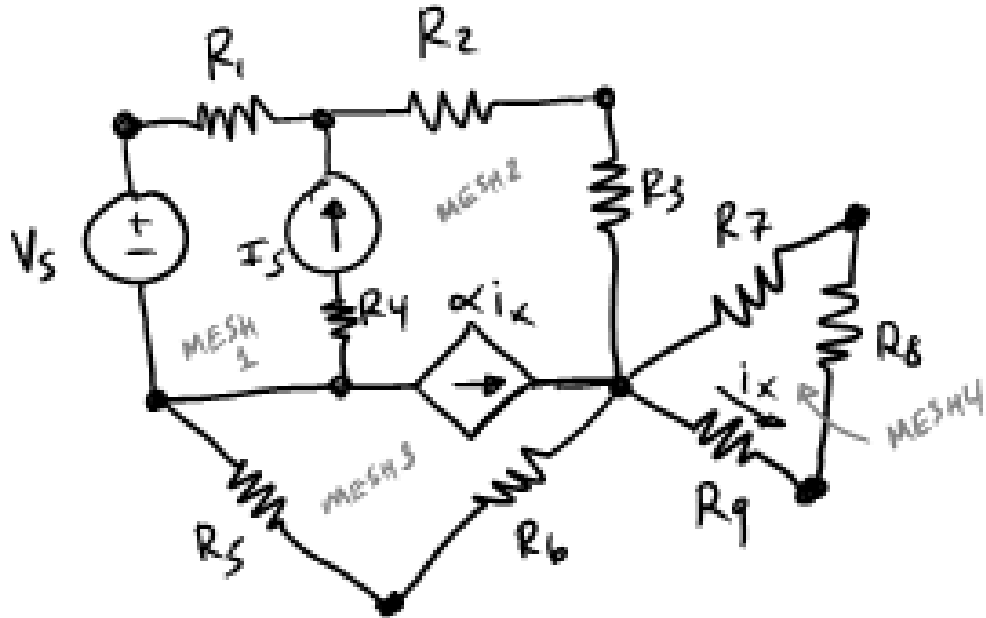

In the box below, provide your answer with equations in this form or lose points (i_1 refers to mesh current 1, etc:

$$\underline{\quad} i_1 + \dots + \underline{\quad} i_n = \underline{\quad}$$

Solution:

*"I don't see much sense in that," said Rabbit.
"No," said Pooh humbly, "there isn't. But there was going to be when I began it.
It's just that something happened to it along the way."
-Winnie the Pooh*

Problem 4 *Equivalent circuits (X points)*

a) *Provide the simplest equivalent circuit for the grey box (measured from terminals a and b).*

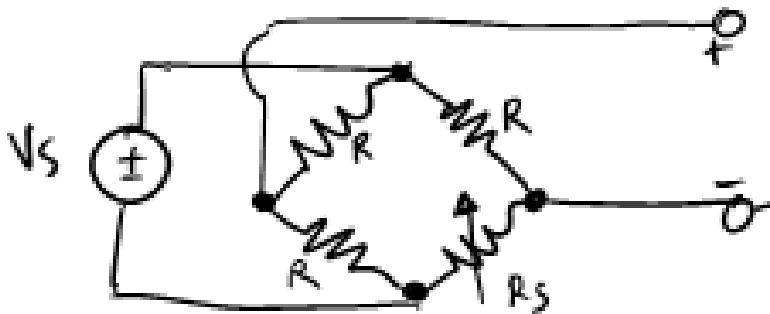

Solution:

b) Solve for V_{out} (12.5 points)

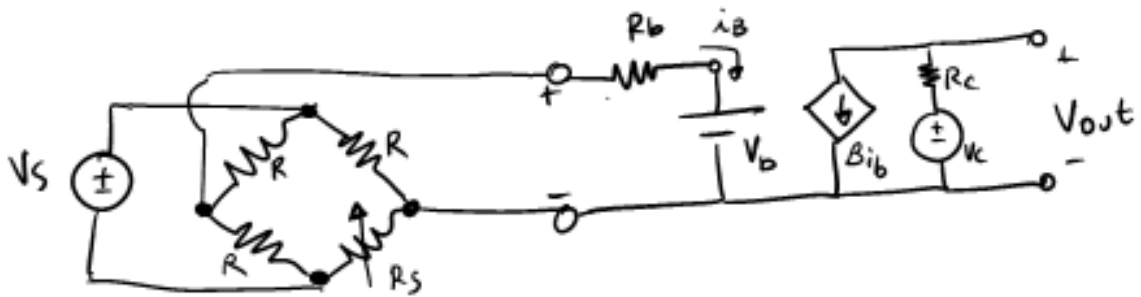

Solution: