

Chemical Kinetics and Reaction Engineering

MIDTERM EXAMINATION II

Friday, April 9, 2010

The exam is 100 points total and 20% of the course grade.

*Please read through the questions carefully
before giving your response.*

Question Number	Your Points	Possible Points
1		40
2		30
3		30
Total		100

Name: _____

SID: _____

You are allowed one 8.5" x 11" sheet of paper and a calculator for this exam.

Problem 1 CSTRs in Thermal Equilibrium (40 points)

Two steady-state, liquid-phase CSTRs are placed in thermal equilibrium with each other, meaning that heat transfer is so rapid between the two reactors that both are at a fixed temperature T_1 . The overall system comprising both CSTR 1 and CSTR 2 is adiabatic meaning that there is no heat transfer to the external surroundings.

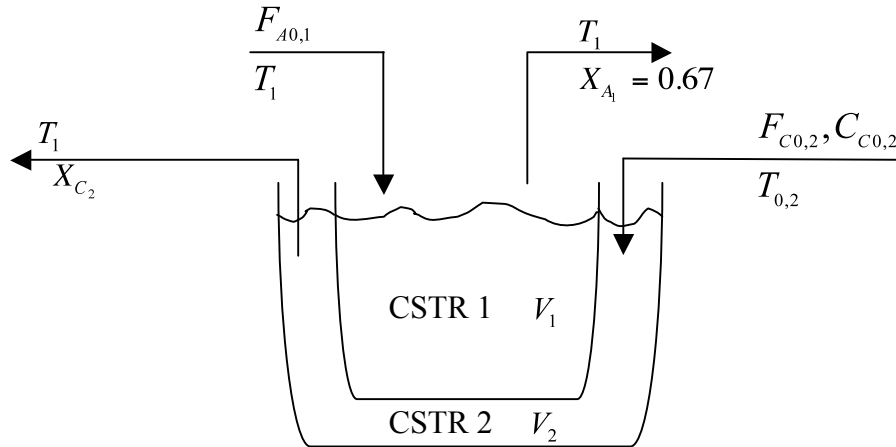

In CSTR 1, the following elementary, exothermic reaction takes place:

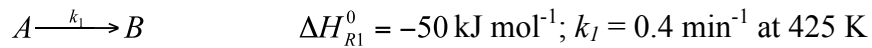

Pure A enters CSTR 1 at a molar rate $F_{A0,1} = 50 \text{ mol min}^{-1}$, and temperature T_1 .

In CSTR 2 ($V_2 = 100 \text{ L}$), the following elementary, endothermic reaction takes place:

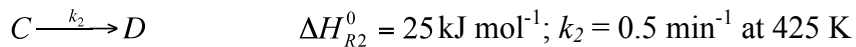

Pure C ($C_{C0,2} = 3 \text{ mol L}^{-1}$) enters CSTR 2 at a molar rate $F_{C0,2}$, and temperature $T_{0,2}$.

All species have a heat capacity $C_p = 45 \text{ J mol}^{-1} \text{ K}^{-1}$ that is independent of temperature. Neglect any shaft work for both CSTRs.

(a) If CSTR 2 is operated isothermally ($T_{0,2} = T_1$), what must be the inlet molar flow rate F_{CO_2} ? (15 points)

(b) Suppose now that $T_{0,2} < T_1$. Write the equation that is needed to solve for the new inlet molar flow rate $F_{CO,2}$ such that both reactors are maintained at a steady-state temperature T_1 , in terms of variables provided above. ***Do not solve – just write the single equation that can be used to solve for $F_{CO,2}$.*** How do you expect $F_{CO,2}$ to change qualitatively compared to part (a)? Explain why in one sentence – longer answers will be penalized (25 points)

Problem 2 Wall-Cooled Differential Reactor (30 points)

The following gas-phase elementary reaction,



is to be carried in a isobaric wall-cooled, steady state differential reactor. Reactant B is fed to the reactor at a temperature T_0 , a molar flow rate F_{B0} , and a volumetric flow rate v_0 . The conversion of B is $X=0.01$, and the temperature of the outlet stream is T . The pre-exponential factor, A , and activation energy, E_a , are known for this reaction. Also, the reaction is highly exothermic, with a known enthalpy of reaction of ΔH_{rxn}^0 .

Due to the differential nature of the reactor, there are no temperature gradients in the system. That is to say, the temperature is uniform throughout the reactor at a value of T . The heat transfer coefficient of the reactor is UA , and the heat capacities are $C_{P,B}$ and $C_{P,C}$, where $C_{P,C}=2C_{P,B}$.

- (a) Derive an expression for the residence time, τ_0 , of the reactor in terms of variables given in the problem statement. (10 points)

(b) Would your expression for part (a) be the same if $X = 0.9$? Explain in less than 2 sentences. (10 points)

(c) What is the temperature of the cooling fluid, T_{amb} , required to operate under the conditions in part (a)? Express your answer in terms of variables given in the problem statement. Also, sketch a plot of T_{amb} vs. ΔH_{rxn}^0 , and provide an expression for the intersection of the curve with the y-axis (10 points)

Problem 3 Surface-Catalyzed Reaction (30 points)

For the overall reaction $A + B \rightarrow \frac{1}{2} D$, consider the following mechanism for a surface catalyzed reaction:

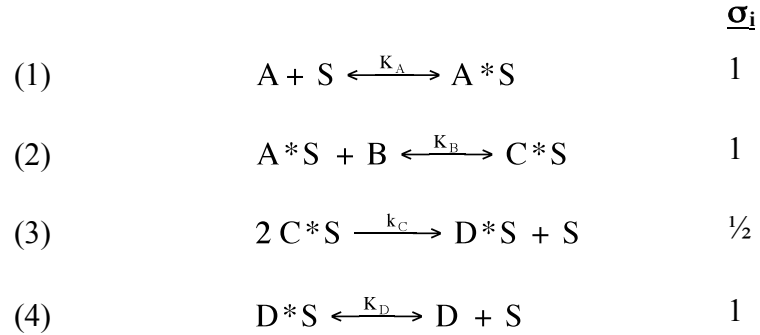

where S represents vacant surface sites, A*S, C*S and D*S represent surface-bound intermediates, and A, B and D represent stable gas-phase species. Step (3) in the series is irreversible, while all other reactions in the series are quasi-equilibrated. The total surface concentration of sites of the catalyst is known and is C_T .

- a) Derive an expression for the rate of reaction in terms of readily measurable quantities P_A , P_C , P_D , C_T and appropriate equilibrium and rate constants. (15 points)

b) What is the rate expression if S is the most abundant surface intermediate (MASI)? (7.5 points)

c) If C*S is MASI, then the overall reaction rate is $r = 2k_c K_B K_A P_B P_A C_T$. In this case, derive an expression for the apparent activation energy of the system, E_{app} , in terms of the activation energies and heats of adsorption of the relevant reaction steps and components, respectively. (7.5 points)