

Physics 8A, Section 1 (Speliotopoulos)
Final Exam, Spring 2009
Berkeley, CA

Rules: *This final exam is closed book and closed notes. You are allowed three sides of two sheets of 8.5" x 11" paper on which you can write whatever notes you wish. You are **not** allowed to use calculators of any type, and any cellular phones must remain off and in your bags for the duration of the exam. Any violation of these rules constitutes an act of academic dishonesty, and will be treated as such.*

Numerical calculations: *This exam consists of six problems, and each one is worth 25 points. One of the problems asks you to calculate numbers. I have chosen the parameters in this problem so that the answers can be expressed in terms of rational numbers. However, if you find that in your calculation of this problem you end up with an expression which you cannot evaluate, simplify the expression as much as you can and leave it. You can find the sheet of formulas from the course website on the last two pages of the exam.*

Please make sure that you do the following during the midterm:

- Write your name, discussion number, ID number on all documents you hand in.
- Make sure that the grader knows what s/he should grade by circling your final answer.

We will give partial credit on this exam, so if you are not altogether sure how to do a problem, or if you do not have time to complete a problem, be sure to write down as much information as you can on the problem. This includes any or all of the following: Drawing a clear diagram of the problem, telling us how you would do the problem if you had the time, telling us why you believe (in terms of physics) the answer you got to a problem is incorrect, and telling us how you would mathematically solve an equation or set of equations once the physics is given and the equations have been derived. Don't get too bogged down in the mathematics; we are looking to see how much physics you know, not how well you can solve math problems.

If at any point in the exam you have any problems, just raise your hand, and we will see if we are able to answer it.

Before the exam begins, write the following information on the front page of your bluebook and sign your bluebook!

Name: _____ Disc Sec Number: _____

Signature: _____ Disc Sec GSI: _____

Student ID Number: _____ Disc Sec Time: _____

You must show your student ID when you hand in your exam!

1. When a block is carefully placed on the incline shown below, the block does not slide down the incline and remains at rest. When the block is then tapped slightly so that it starts moving, it slides down the incline. What is the maximum and the minimum that θ can be? Take the coefficient of static and kinetic friction between the block and the incline to be μ_s and μ_k , respectively.

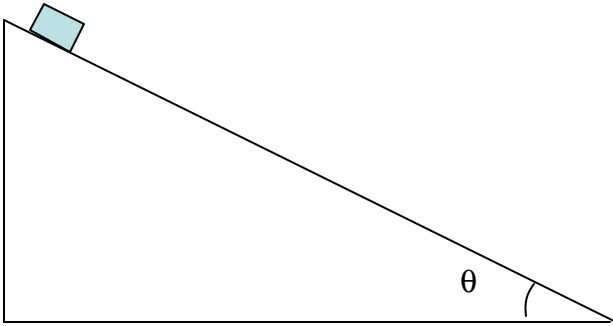

-
2. Block A with mass, m , is connected to a spring, and is in its equilibrium position (see figure). Block B also has mass, m . It moves with a velocity, v_0 , to the right, and collides with Block A. All surfaces are frictionless, and the collision is elastic.
- If after a time, T_c , Block A is again at rest, and Block B is now moving to the left, what is the spring constant of the spring?
 - What is the maximum distance, D , that the spring compresses?

Make sure you show all your work when answering these questions. Do not simply state conclusions without justifying them!

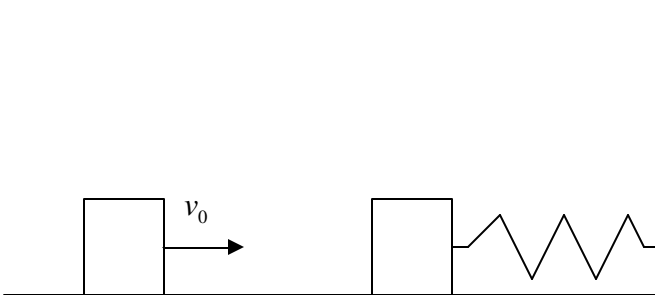

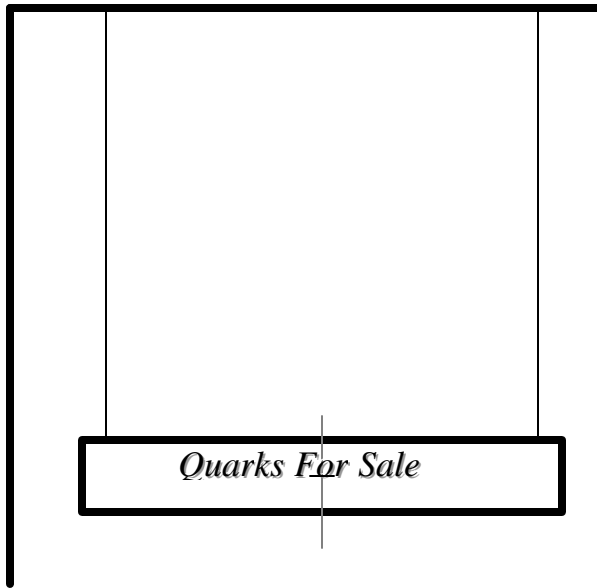

between the two wires as, l . (Note that your answer need not depend on all of the above variables.)

3. The sign in the figure to the left hangs in front of a store. When the wind blows through the wires hanging from the beam, both wires oscillate. Because the sign is slightly irregular, the center of mass is *not* located at the physical center of the sign, and the left and right wires oscillate at different fundamental frequencies, f_0^{Left} and f_0^{Right} , with $f_0^{Left} > f_0^{Right}$. Determine whether the center of mass is closer to the left or to the right wire, and find the distance, d , between the center of mass of the sign and physical center of it. Take the mass of the sign as, M , the linear density of the wires as, μ , and both the length of the wires and the separation

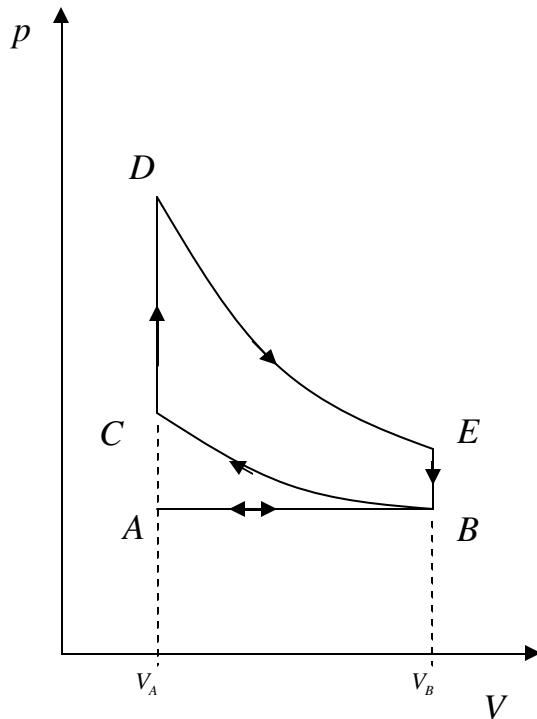

4. The thermodynamical cycle to the left is the cycle likely used by your car. Find the total work, W , done in a complete cycle (expressed in terms of the pressure at B , C , D , and E , and the volume at A and B), and the efficiency, e , of the cycle (expressed in terms of the temperature at D and E). The gas used has a given value of γ .

The cycle has the following stages:

- $A-B$: Isobaric
- $B-C$: Adiabatic
- $C-D$: Isometric
- $D-E$: Adiabatic
- $E-B$: Isometric
- $B-A$: Isobaric

5. You are given a block of ice with mass, m_{ice} , and a container of water with mass, M_w , and temperature, T_w . If all the water freezes when the ice is placed in the water, what is the maximum amount of water, $\frac{M_w}{m_{ice}}$, that the ice can freeze? You can assume that the container is thermally isolated. Express your answer in terms in terms of any or all of the following: L_{ice} , the latent heat of fusion for ice; c_{ice} , the specific heat capacity of ice; c_w , the specific heat capacity of water; and T_{273} , the freezing point of water on the Kelvin scale. (Yes, I realize that I am not giving you the temperature of the ice.)

6. Consider the cylinder of water shown below. It has a diameter, D , and water is filled to a height, h_T , in it. At a height, $h_0 = \frac{5}{8}h_T$, from the table, there is on circular opening whose diameter, d , can be adjusted. What must $\frac{d}{D}$ be so that so that the water rushing out of the opening hits the table a distance, h_T , from the opening? *Do not assume that the velocity of the water is zero at the top of the water column.*

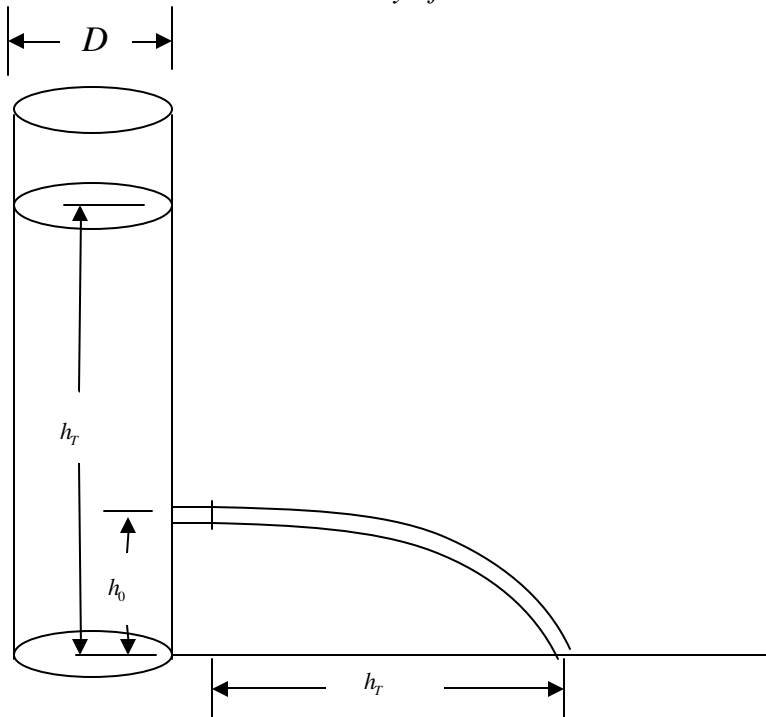

Physics 8A

Possibly useful formulas:

$x = x_0 + vt + \frac{1}{2}at^2$	$v = v_0 + at$	$v^2 = v_0^2 + 2ax$
$y = \frac{v_{y0}}{v_{x0}}x - \frac{g}{2v_{x0}^2}x^2$	$v = \frac{dx}{dt}$	$a = \frac{dv}{dt}$
$F = ma = m\frac{dv}{dt}$	$F_G = G\frac{mM}{r^2}$	$F_{fr} = \mu_k N$ $F_{fr} \leq \mu_s N$
$\omega = 2\pi f$	$v = r\omega$	$a = \frac{v^2}{r} = r\omega^2$
$F = m\frac{v^2}{r} = mr\omega^2$	$f = \frac{1}{T}$	$I = \Delta p = m\Delta v = \int F dt \approx F\Delta t$
$p = \sum_i m_i v_i$	$F_{ext} = \frac{dp}{dt}$	$x_{cm} = \frac{m_1 x_1 + m_2 x_2}{m_1 + m_2}$ $= \frac{\sum_i m_i x_i}{\sum_i m_i}$
$y_{cm} = \frac{m_1 y_1 + m_2 y_2}{m_1 + m_2}$ $= \frac{\sum_i m_i y_i}{\sum_i m_i}$	$v_{cm} = \frac{\sum_i m_i v_i}{\sum_i m_i}$	$F_{ext} = \left(\frac{1}{\sum_i m_i} \right) \frac{dv_{cm}}{dt}$
$U = mgh$	$U = \frac{1}{2}kx^2$	$K = \frac{1}{2}mv^2$
$E = U + K$	$F = -kx$	$W = \mathbf{F} \cdot \mathbf{x} = Fx \cos \theta = \int F dx$
$P = \frac{dE}{dt}$	$P = \mathbf{F} \cdot \mathbf{v} = Fv \cos \theta = \int F dv$	$\alpha = \frac{d\omega}{dt}$
$\theta = \theta_0 + \omega t + \frac{1}{2}\alpha t^2$	$\omega = \omega_0 + \alpha t$	$\omega^2 = \omega_0^2 + 2\alpha\theta$
$\omega = \frac{d\theta}{dt}$	$L = I\omega$	$\tau = I\alpha = I \frac{d\omega}{dt} = \frac{dL}{dt}$
$\boldsymbol{\tau} = \mathbf{r} \times \mathbf{F} = rF \sin \theta$	$I = \sum_i m_i r_i^2 = \int r^2 dm$	$I = \frac{2}{5}mr^2$ Solid Sphere
$I = \frac{2}{3}mr^2$ Hollow Sphere	$I = mr^2$ Hoop	$I = \frac{1}{2}mr^2$ Disk
$I = \frac{1}{12}mL^2$ Thin Rod about Center	$I = \frac{1}{3}mL^2$ Thin Rod about End	$K = \frac{1}{2}I\omega^2$
$P = \frac{F}{A}$	const = ρ ρgh $\frac{1}{2}\rho v^2$	$F = \eta A \frac{dv}{dy}$

$\text{const} = vA$	$\frac{d^2x}{dt^2} = -\omega^2x$	$x = x_0 \sin(\omega t + \phi)$
$x = x_0 \cos(\omega t + \phi)$	$\omega = \sqrt{\frac{k}{m}}$	$\omega = \sqrt{\frac{g}{L}}$
$f(x \pm vt) \Leftrightarrow \sin(kx \pm \omega t)$	$k = \frac{2\pi}{\lambda}$	$v = f\lambda = \frac{\omega}{k}$
$v = \sqrt{\frac{T}{\mu}}$	$v = 330 \text{ m/s}$	$I = \frac{P}{A} \propto \text{Amplitude}^2$
Moving Source: $f = \frac{f_0}{1 \pm v_s/v}$	Moving Observer: $f = (1 \pm v_o/v) f_0$	$\omega = \frac{n}{2L} v$
$A[\sin(\omega_1 t) + \sin(\omega_2 t)]$ $= 2A \sin\left[\frac{1}{2}(\omega_1 + \omega_2)t\right]$ $\times \sin\left[\frac{1}{2}(\omega_1 - \omega_2)t\right]$	$\frac{d}{2\lambda} \cos\theta = 0, 2, 4, 6, 8, \dots$	$\frac{d}{2\lambda} \cos\theta = 1, 3, 5, 7, \dots$
$\frac{dQ}{dt} = \kappa \frac{A}{L} \Delta T$	$\frac{dQ}{dt} = \kappa \frac{A}{L} \Delta T$	$I = e\sigma T^4$
$\lambda = \frac{B}{T}$	$\frac{\Delta l}{l} = \alpha \Delta T$	$W = p\Delta V = \int p dV$
$pV = Nk_B T$	$pV = nRT$	$U = \frac{3}{2} k_B T$
Isothermal: $W = Nk_B T \ln \frac{V_f}{V_i}$	$C_v = \frac{3}{2} R$ (monatomic)	$C_p = \frac{5}{2} R$ (monatomic)
Adiabatic monatomic: $TV^{2/3} = \text{const}$	Adiabatic monatomic: $pV^{5/3} = \text{const}$	$\Delta E = W + Q$
$\Delta S = \frac{\Delta Q}{T}$	$\Delta S \geq 0$	$e = 1 - \frac{T_L}{T_H}$
$\cos(45) = \sin(45) = \frac{\sqrt{2}}{2} = 0.707$	$\cos(60) = \sin(30) = \frac{1}{2}$	$\cos(30) = \sin(60) = \frac{\sqrt{3}}{2} = 0.866$
$\sin^2(\theta) + \cos^2(\theta) = 1$	$\sin(a+b) = \sin a \cos b + \cos a \sin b$	$\cos(a+b) = \cos a \cos b - \sin a \sin b$