

**Physics 7B, Speliotopoulos  
Second Midterm, Fall 2012  
Berkeley, CA**

**Rules:** *This midterm is closed book and closed notes. You are allowed two sides of one-half sheet of 8.5" x 11" of paper on which you may write whatever you wish. You may not use any type of calculators on this exam. Cell phones must be turned off during the exam, and placed in your backpacks.*

*Please make sure that you do the following during the midterm:*

**- Show all your work in your blue book**

- Write your name, discussion number, ID number on all documents you hand in.
- Make sure that the grader knows what s/he should grade by circling your final answer.
- Cross out any parts of the your solutions that you do not want the grader to grade.

*Each problem is worth 20 points. We will give partial credit on this midterm, so if you are not altogether sure how to do a problem, or if you do not have time to complete a problem, be sure to write down as much information as you can on the problem. This includes any or all of the following: Drawing a clear diagram of the problem, telling us how you would do the problem if you had the time, telling us why you believe (in terms of physics) the answer you got to a problem is incorrect, and telling us how you would mathematically solve an equation or set of equations once the physics is given and the equations have been derived. Don't get too bogged down in the mathematics; we are looking to see how much physics you know, not how well you can solve math problems.*

*If at any point in the exam you have any questions, just raise your hand, and we will see if we are able to answer them.*

**Copy and fill in the following information on the front of your bluebook:**

Name: \_\_\_\_\_ Disc Sec Number: \_\_\_\_\_

Signature: \_\_\_\_\_ Disc Sec GSI: \_\_\_\_\_

Student ID Number: \_\_\_\_\_

---

- The figure to the right shows a parallel plate capacitor with a separation,  $d$ , which is connected to a potential,  $V$ . A sphere with mass,  $M$ , and charge,  $Q$ , is attached to the end of a string that makes an angle  $\theta$  from the vertical. Find  $Q$  in terms of  $M$ ,  $V$ ,  $d$ ,  $\theta$ , and  $g$ . (Do not worry about image charges, if you know what they are.)
- The capacitor network below has four capacitors connected to a voltage source,  $V$ , with  $C_1 = 5C_2$ . A switch,  $S$ , in the network is open in Fig. A, and closed in Fig. B. If  $Q_{open}$  is the charge on the **top left capacitor** when the switch is open, and  $Q_{close}$  is the charge on this capacitor when the switch is closed, what is  $Q_{open}/Q_{close}$ ?

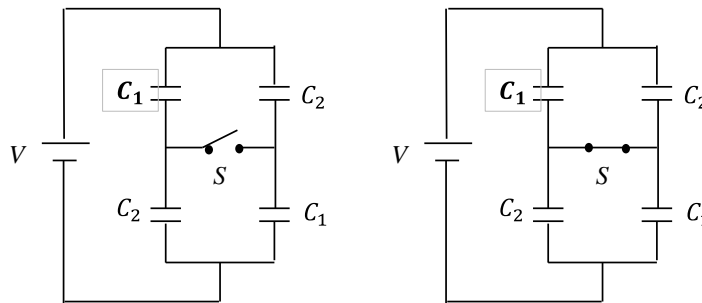
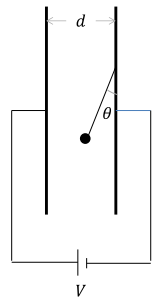
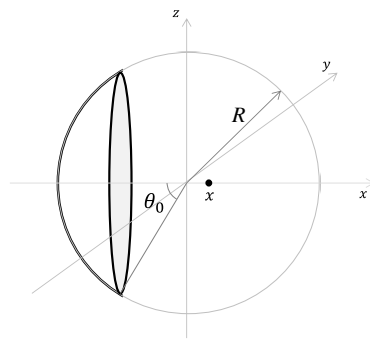

Fig. A

Fig. B



- The figure to the left shows a part of a *hollow*, non-conducting sphere of radius  $R$  that has a charge on the surface with charge per unit area,  $\sigma$ . Take  $V(\infty) = 0$ .

- The potential at a point  $x \ll R$  is

$$V(x) = V_0 \left( 1 + \alpha \frac{x}{R} \right),$$

to first order in  $x/R$ . Find  $V_0$  and  $\alpha$  in terms of  $\sigma$ ,  $R$ , and  $\theta_0$ . Remember that for  $u \ll 1$ ,  $(1 + u)^p \approx 1 + pu$ .

- Find the three components of the electric field at the origin using the results from part a. (You will still receive partial credit even if you were not able to find expressions for  $V_0$  and  $\alpha$ ).

- The figure to the right shows an insulating, infinitely long cylinder with a constant charge density,  $\rho$ , and radius,  $R$ . Inside the cylinder is an empty spherical pocket with radius,  $R/2$ . What is the electric field at the points A, B and C shown?

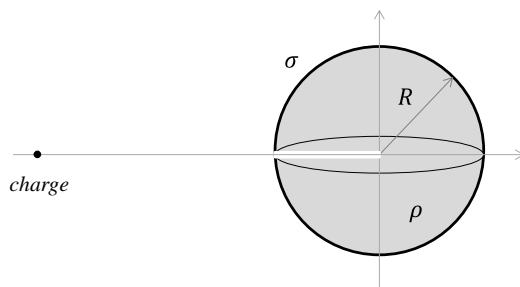
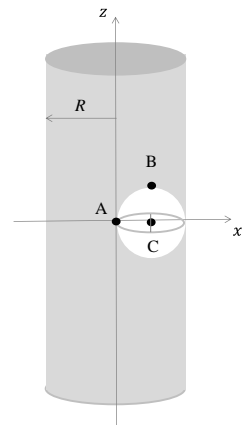

- The figure to the left shows a thin, hollow, non-conducting sphere with radius,  $R$ , that has a charge,  $Q_1 > 0$ , spread uniformly on the *surface*. Inside the sphere is a charge  $Q_2 = -Q_1/2$  spread uniformly throughout its *volume*. A small hole is drilled into the center of the sphere.

- Assume that the presence of the small hole does not affect the electric potential of the sphere significantly. Find the potential,  $V(r)$ , for  $r < R$  and  $r \geq R$ . Take  $V(\infty) = 0$ .
- A small negative charge is placed at a radius,  $a > R$ , directly in front the hole and is released from rest. If the charge enters the hole and comes to rest at the center of the sphere, find  $a$  in terms of  $R$ ,  $\sigma$ , and  $\rho$ .