

Final  
EE40  
Spring 2012

NAME: \_\_\_\_\_ SSID: \_\_\_\_\_

*Instructions*

Read all of the instructions and all of the questions before beginning the exam.

There are 5 problems in this exam. The total score is 125 points. Points are given next to each problem to help you allocate time. Do not spend all your time on one problem.

Unless otherwise noted on a particular problem, you must show your work in the space provided, on the back of the exam pages or in the extra pages provided at the back of the exam.

Draw a BOX or a CIRCLE around your answers to each problem.

Be sure to provide units where necessary.

GOOD LUCK!

<b>PROBLEM</b>	<b>POINTS</b>	<b>MAX</b>
<b>1</b>		<b>20</b>
<b>2</b>		<b>45</b>
<b>3</b>		<b>20</b>
<b>4</b>		<b>20</b>
<b>5</b>		<b>20</b>

“Whatever in creation exists without my knowledge exists without my consent...  
The freedom of birds is an insult to me. I’d have them all in zoos.”  
- The Judge

**Blood Meridian**, Cormac McCarthy

**Problem 1 Nodal and Power (20 points)**

Consider the following circuit:

a)  $V_s$  is a sinusoidal voltage source. Solve for all node voltages. (15 points)

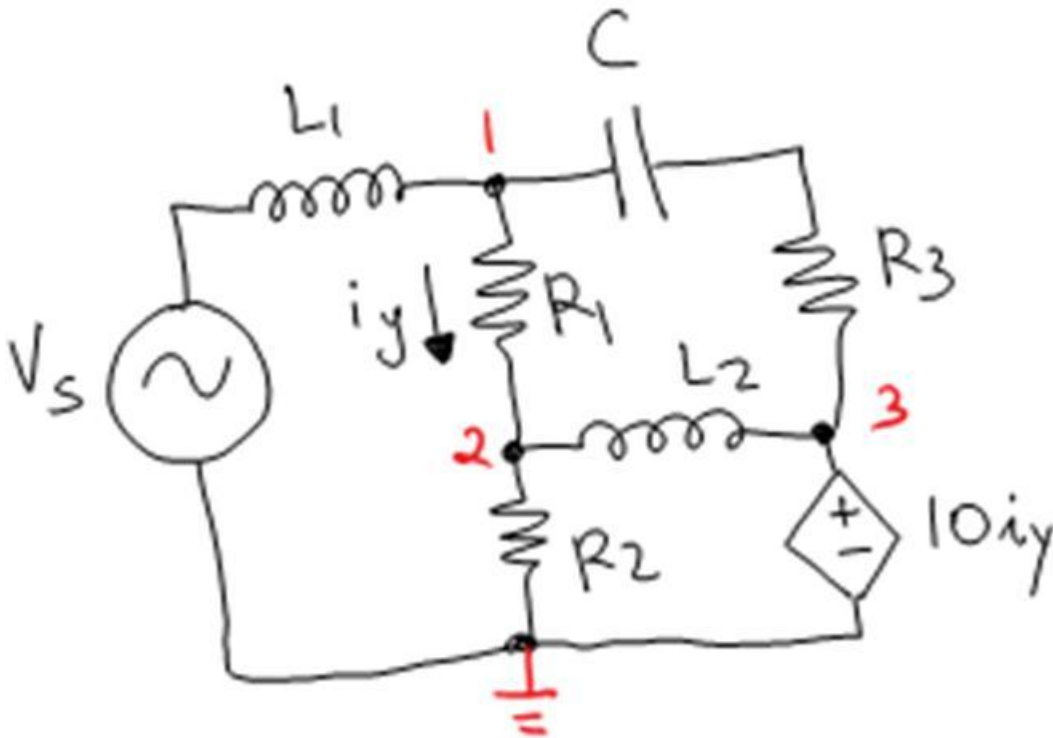

In the box below, provide your answer in this form or **LOSE POINTS**

$$\underline{\quad} v_1 + \underline{\quad} v_2 + \underline{\quad} v_3 + \dots \underline{\quad} v_n = \underline{\quad}$$

**Solution:**

**b)** Now assume  $V_S$  has an amplitude of 1 V and a frequency of 1 MHz,  $L_1 = L_2 = 0.159 \mu\text{H}$ ,  $C = 0.159 \mu\text{F}$ ,  $R_1 = R_2 = R_3 = 1 \Omega$ . Is the dependent source absorbing or delivering power? (2.5 points)

**c)** How much power is the dependent source absorbing or delivering? (2.5 points)

“Ph'nglui mglw'nafh Cthulhu R'l'yeh wgah'nagl fhtagn.”  
 - *The Call of Cthulhu*, H. P. Lovecraft

**Problem 2 Transfer Functions (25 points)**  
 Consider the two circuits below.

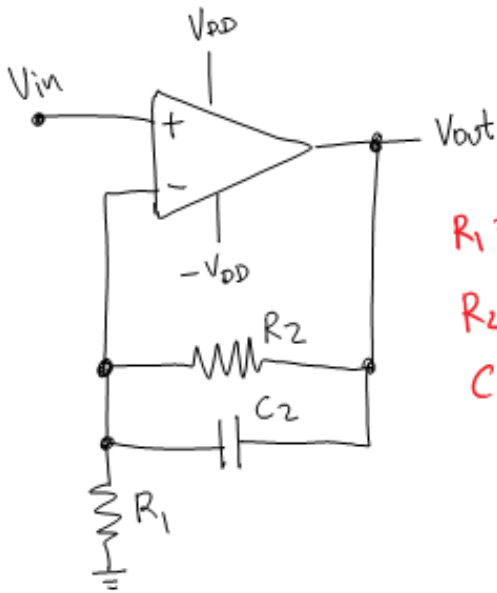

$R_1 = 1\text{k}\Omega$   
 $R_2 = 9\text{k}\Omega$   
 $C_2 = 0.1\mu\text{F}$

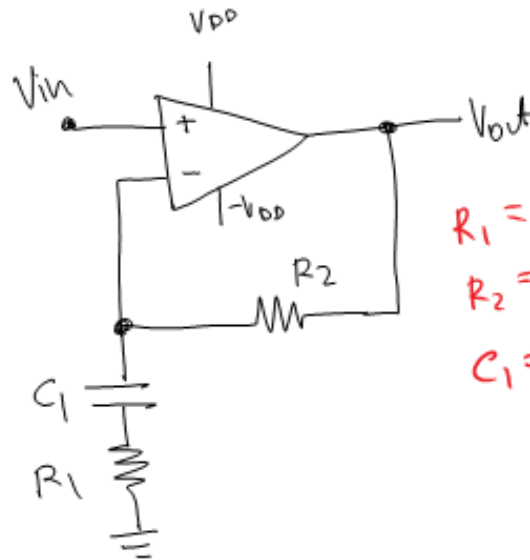

$R_1 = 1\text{k}\Omega$   
 $R_2 = 9\text{k}\Omega$   
 $C_1 = 0.1\mu\text{F}$

a) Provide **SYMBOLIC** transfer functions for BOTH circuits. (20 points)

Transfer function for the left circuit:	Transfer function for the right circuit:

b) Provide Bode magnitude and phase plots for both circuits: (15 points)

**Component values are provided in the circuit.**

**Magnitude Bode plot for left circuit**

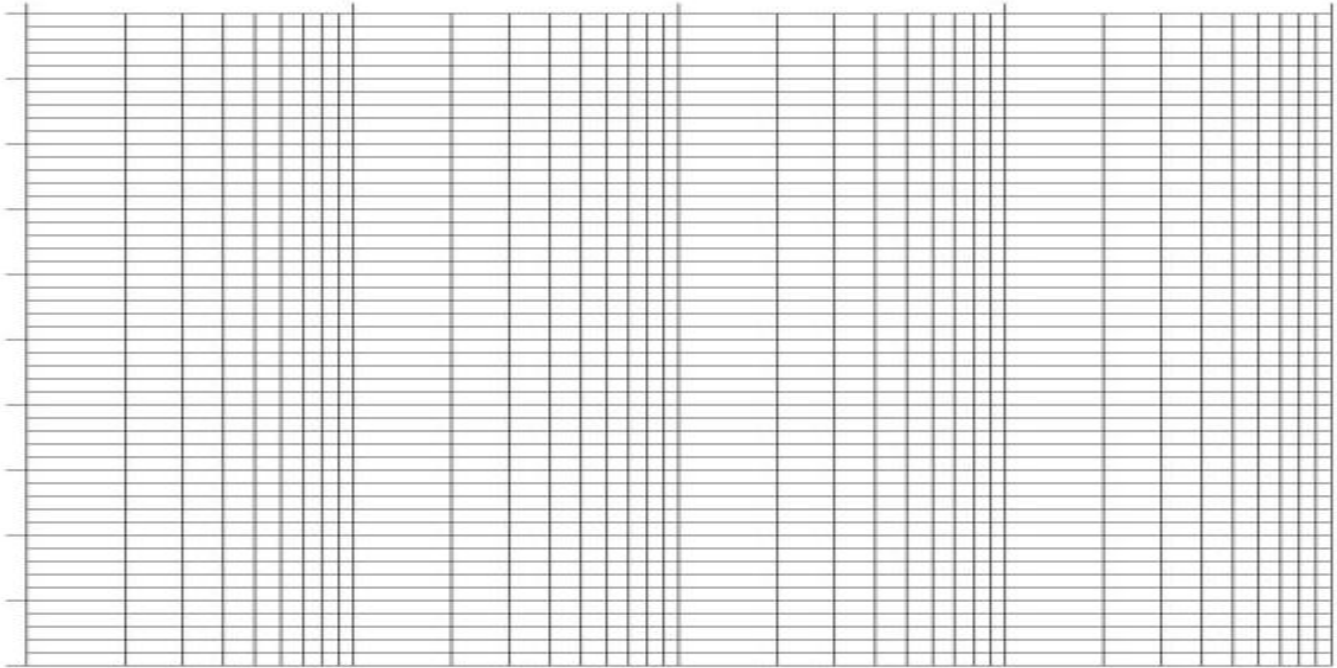

**Phase Bode plot for left circuit**

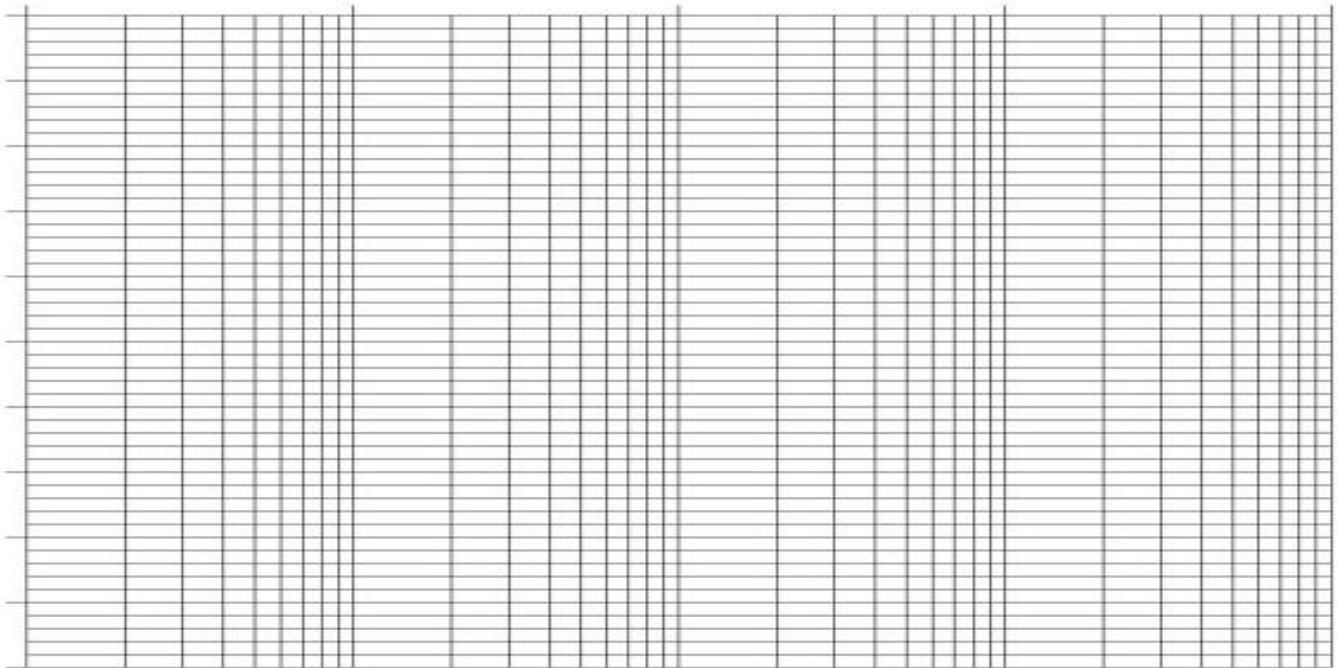

**Magnitude Bode plot for right circuit**

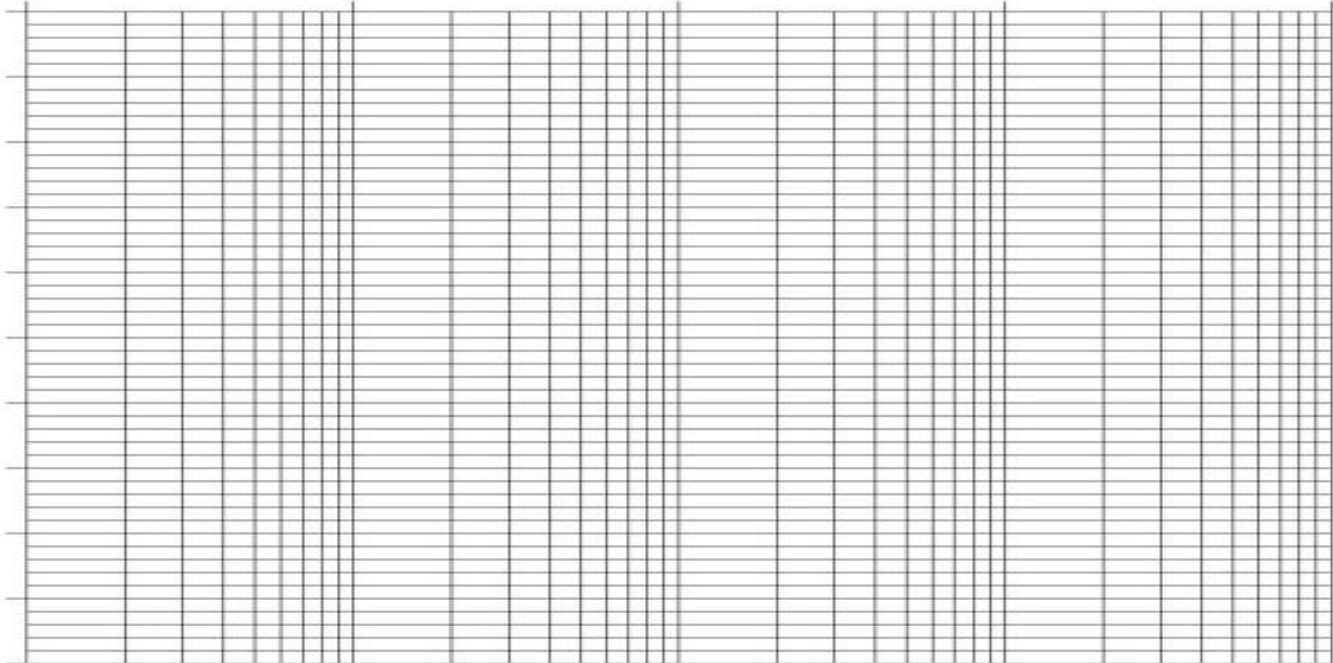

**Phase Bode plot for right circuit**

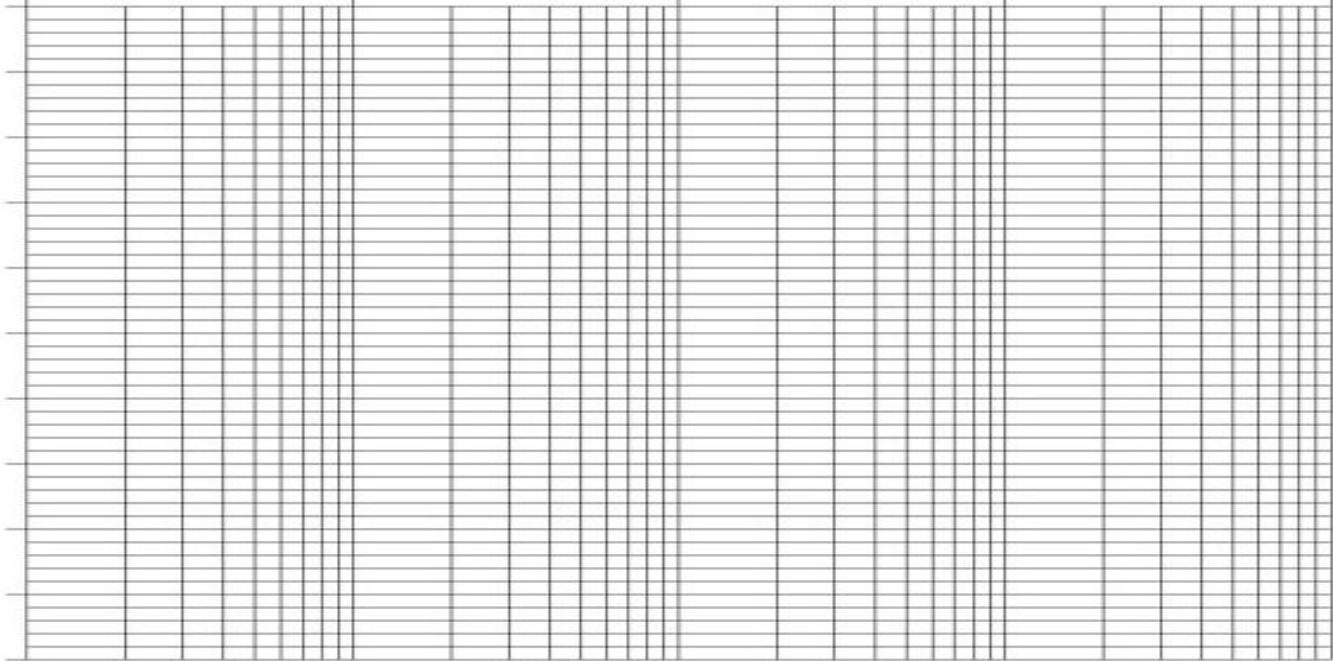

c) Provide the magnitude Bode plot for the following circuit: (5 points)

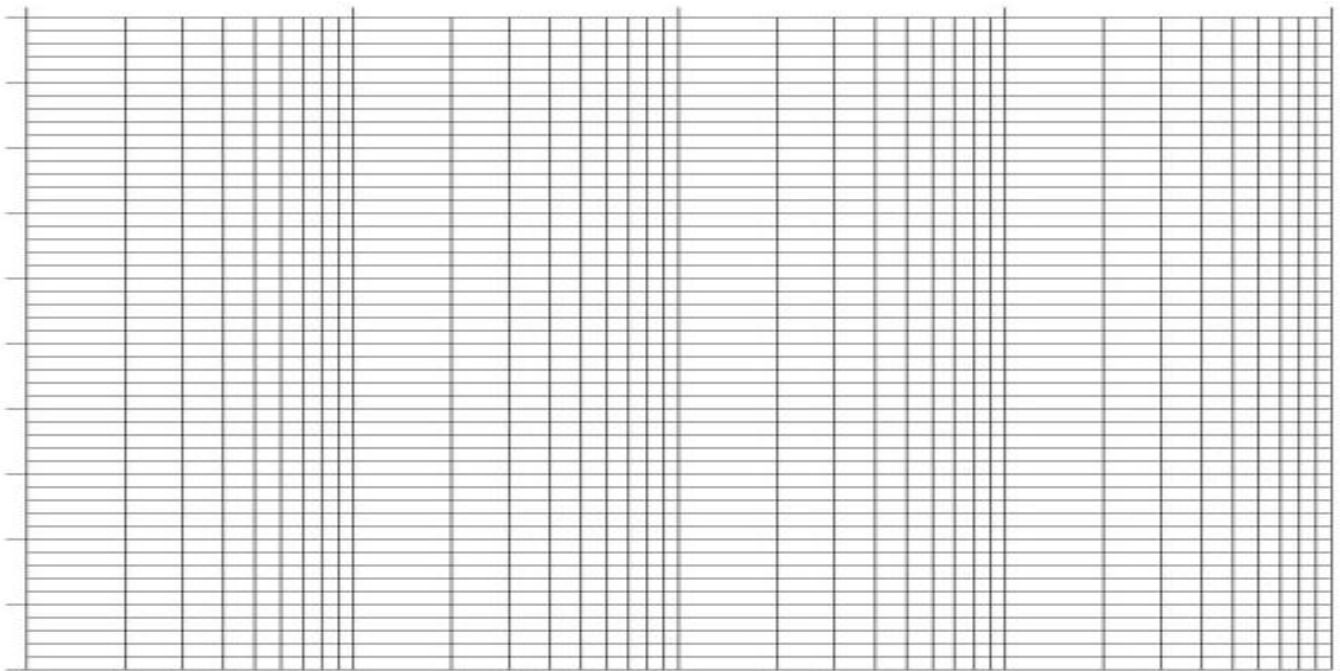
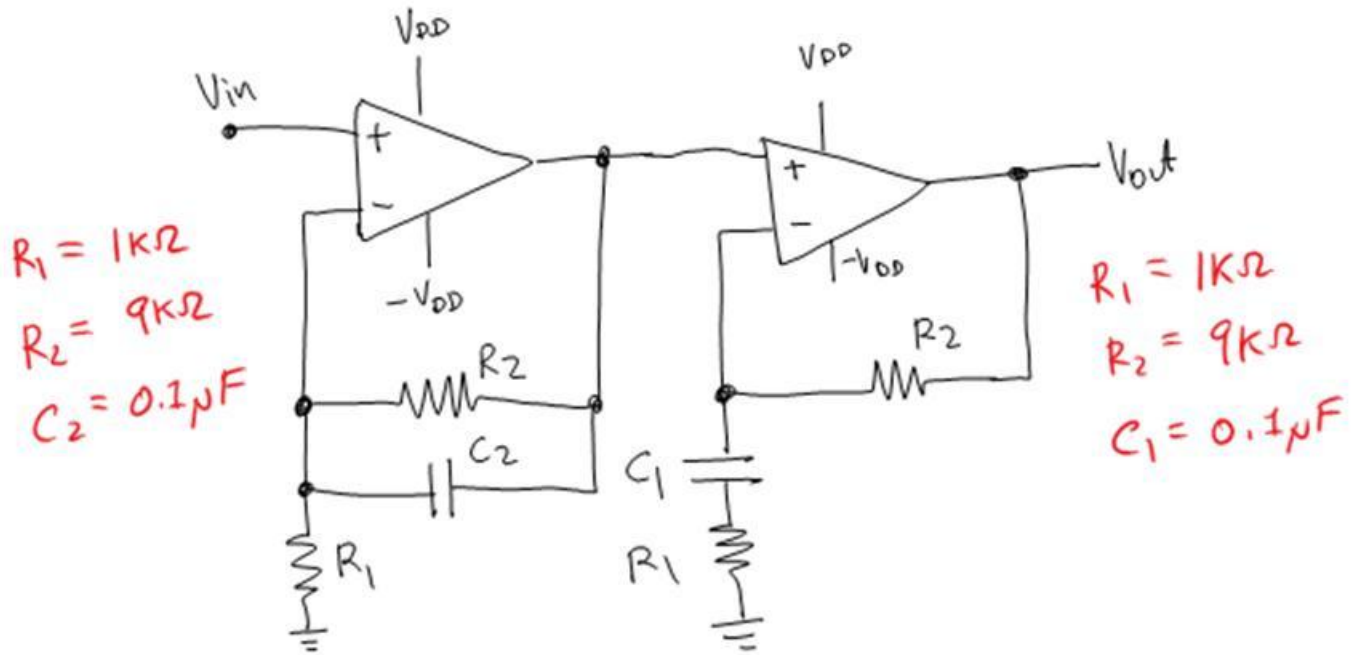

d) In **THREE WORDS OR LESS**, what does this circuit do? (5 points)

\_\_\_\_\_

“Conan stood paralyzed in the disruption of the faculties which demoralizes anyone who is confronted by an impossible negation of sanity.”

- *The Devil in Iron*, Robert E. Howard

**Problem 3** Time domain (20 points)

Consider the circuit below. Switch S1 opens at  $t = 0$ . Switch S2 closes at  $t = 10$  ms.

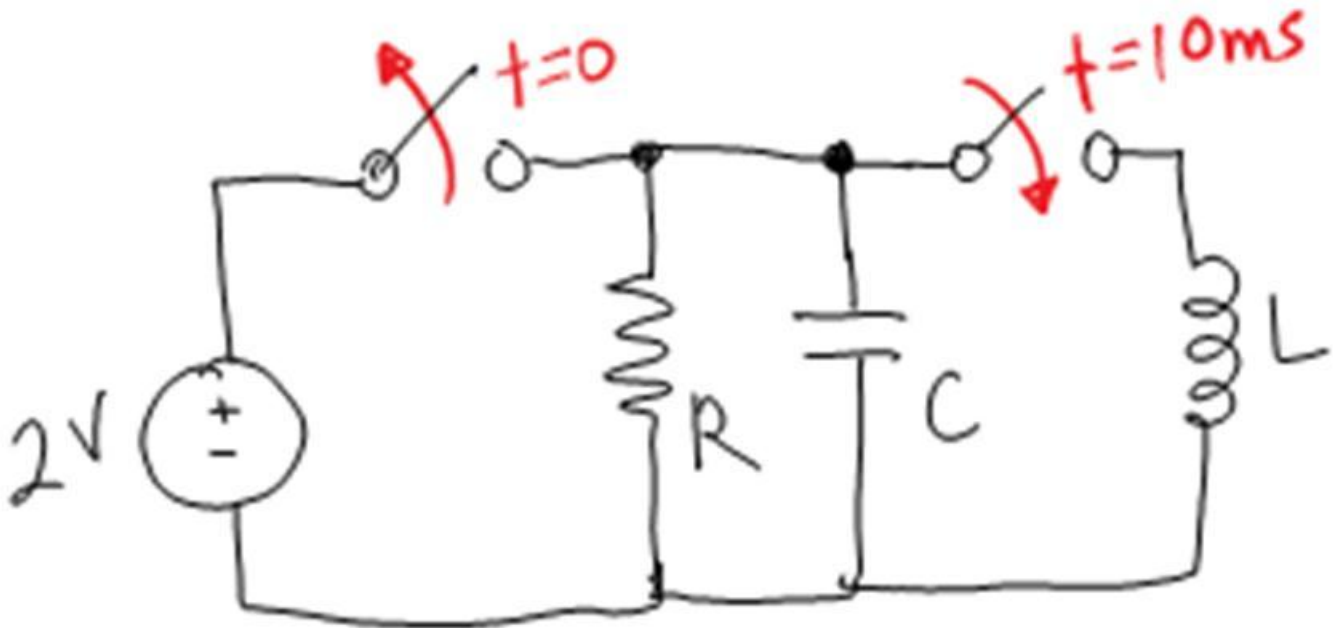

**$R = 1 \text{ k}\Omega$ ,  $C = 10 \text{ }\mu\text{F}$ ,  $L = 100 \text{ }\mu\text{H}$**

a) Provide an expression for  $v_C(t)$  for  $0 > t > 10$  ms. (10 points)

b) Provide an expression for  $v_C(t)$  for  $10 \text{ ms} > t > \infty$  (10 points)



“Do not consider it proof just because it is written in books, for a liar who will deceive with his tongue will not hesitate to do the same with his pen.”

- Maimonides

**Problem 4** Thevenin Equivalent (20 points)

Consider the circuit below:

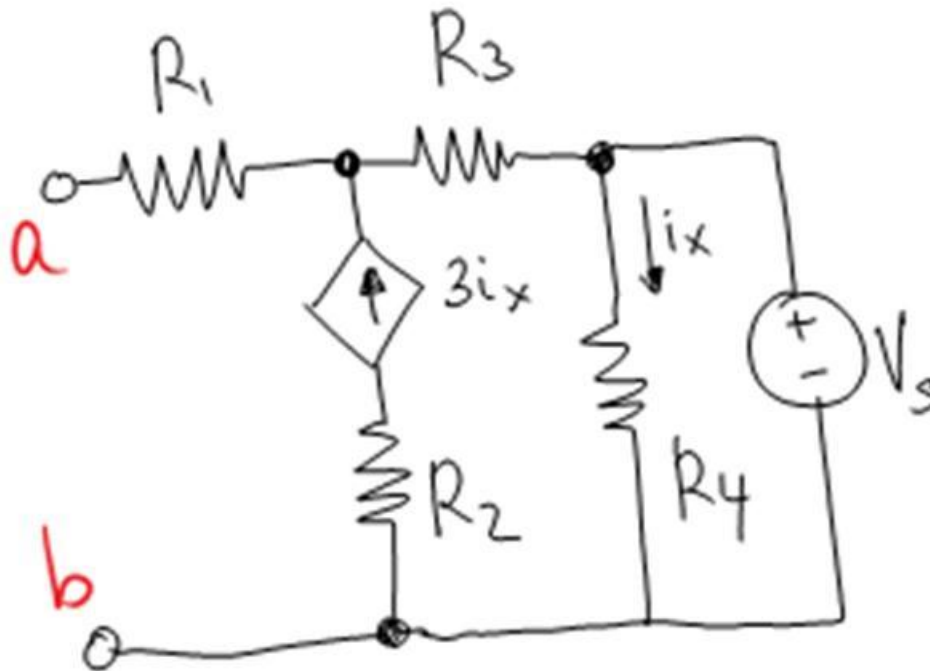

a) Find the Thevenin equivalent circuit when looking in at terminals a,b. (10 points)

b) What is the value of the load I would have to connect across a,b so as to obtain maximum power transfer into that load? Your answer should be symbolic, obviously. (10 points)

“A gem cannot be polished without friction, nor a man perfected without trials.”

- **Lucius Annaeus Seneca**

**Problem 5** *Design (20 points)*

In the box below, provide a circuit which can take a 1 mA, 1 kHz sinusoidal current and amplify it to 10 mA, 1 kHz, sinusoidal current. Your design must include at least one op amp. All op amps have a very large open loop gain, 1 G $\Omega$  input resistance and 10  $\Omega$  output resistance.

# Scratch

# Scratch