

Mid-Term Examination No. 1 – **Duration 1 hour and 45 minutes**

Instructions:

- Read these instructions. Do not turn the exam over until instructed to do so.
- Work all problems. Pace yourself so that you have time to work on each problem. Reasonable assumptions and approximations should be made where necessary.
- Show all relevant work. Credit will not be given for key elements of the solution that are not apparent.
- Partial credit will be given if procedures are outlined clearly.
- Work the solutions for each of the problems on separate sheets, working on one side of each sheet of paper. One problem solution may span more than one sheet. However, do not show the work for more than one problem on any given sheet. Staple the solution sheets to this cover sheet, problem 1 first, then problem 2, etc.
- If you have any questions, or need any paper or other materials, walk to the front of the classroom and ask the exam proctor. Do not raise your hand to get the proctor's attention, and do not call out questions from your seat.
- Neatness counts five percent of the grade. Therefore, write neatly and organize your solutions to make checking as easy as possible.
- Unless otherwise stated, all problems use the ACI 318-11 strength design method, and all concrete is normal weight.

	Possible Points	Score
Problem 1	30	_____
Problem 2	35	_____
Problem 3	35	_____
TOTAL	100	_____

**Problem 1 (30 points)**

A beam is has the I-section shown with different flange widths.  $f'_c = 4$  ksi, and  $f_y = 60$  ksi. **Considering the full width of the flanges effective both in tension and compression and ignoring the contribution of steel in compression** calculate:

- 1.1) The nominal flexural strength when the top reinforcement is in tension. **(12 points)**
- 1.2) The nominal flexural strength when the bottom reinforcement is in tension. **(12 points)**
- 1.3) What is the effective width of the flanges, according to ACI, for the two cases considered? **(6 points)**

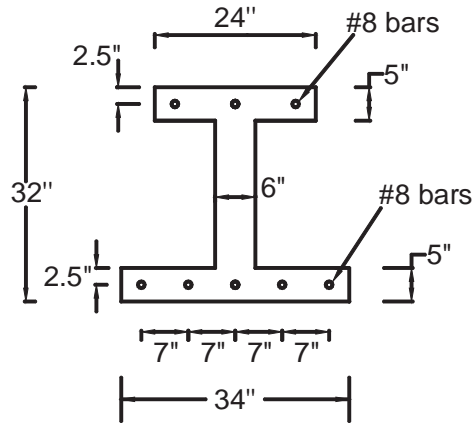

**Problem 2 (35 points)**

**2.1)** The beam ABC with rectangular cross section is considered.  $f'_c = 4$  ksi, and  $f_y = 60$  ksi. The effective depth of the beam is  $d=12$ ."

**2.1.1 - Using #4 stirrups** design the required shear reinforcement of spans AB, and BC. The 14 kips load is already factored. Ignore the self weight of the beam. Assume that the flexural strength of the beam is adequate everywhere. Show a side view as well as a beam section sketch of your shear reinforcement design. **(23 points)**

**2.1.2 -** Using the requirements of the ACI 318 code, determine whether the depth of the beam is adequate so that a detailed deflection calculation is not required. **(4 points)**

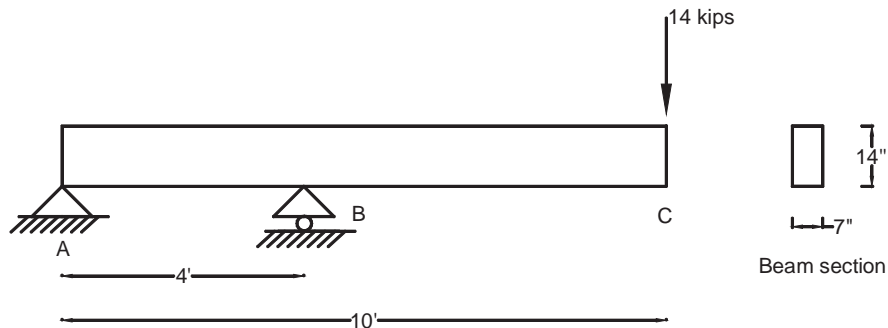

2.2) Calculate the maximum load P that the short cantilever with the rectangular section shown can resist.  $f'_c = 4$  ksi, and  $f_y = 60$  ksi. Assume that the flexural strength is adequate everywhere. (8 points)

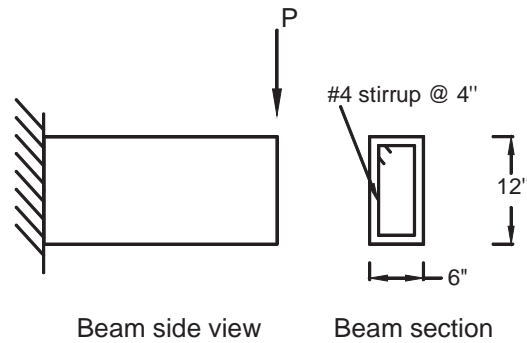

**Problem 3 (35 points)**

For  $f'_c = 4$  ksi, and  $f_y = 60$  ksi check if the length of the splices as well as the development length of the bars is adequate. The loads shown are already factored. All the bar hooks shown are standard and satisfy ACI requirements. Contact splices are considered. The bars are uncoated and the concrete is normal weight. The nominal flexural strength of the beam section with 5#9 in tension is  $M_n = 552$  kips-ft. The nominal flexural strength of the beam section with 4#7 in tension is  $M_n = 282$  kips-ft. The effective depth of the beam is  $d = 27$  inches.

Note: **Do not** check rules 3 to 7 for reinforcement cutoff.

