

Chemistry 1A, Spring 2011

Midterm 1

February 7, 2011

(90 min, closed book)

Name: _____

SID: _____

TA Name: _____

- There are 40 multiple choice questions worth 3 points each.
- There is only one correct answer for each question unless otherwise specified in the question.
- Only answers on the Scantron form will be graded.
- The exam question sheets will NOT be collected.
- Use the back side and page margins as scratch paper.
- The periodic table can be torn off.

Color and Wavelength of Light

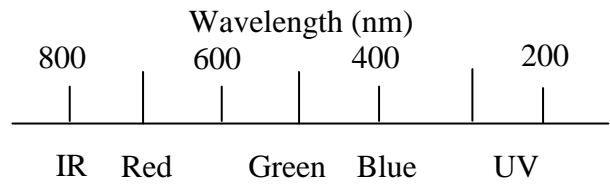

Quantum:

$$E = hv$$

$$\lambda\nu = c$$

$$\lambda_{\text{deBroglie}} = h / p = h / mv$$

$$E_{\text{kin}}(e^-) = hv - \Phi = hv - hv_0$$

$$E_n = -\frac{Z^2}{n^2} R_\infty$$

$$\Delta x \Delta p \sim h$$

$$p = mv$$

$$E_n = h^2 n^2 / 8mL^2; n = 1, 2, 3...$$

$$E_v = (v + 1/2) hA / 2\pi; A = (k/m)^{1/2}$$

$$E_n = n(n+1) hB; B = h/8\pi^2 I; I = 2mr^2$$

$$m = m_A m_B / (m_A + m_B)$$

Ideal Gas:

$$PV = nRT$$

$$E_{\text{kin}} = \frac{3}{2} RT$$

$$v_{\text{rms}} = \sqrt{\frac{3RT}{M}}$$

Constants:

$$N_0 = 6.02214 \times 10^{23} \text{ mol}^{-1}$$

$$R_\infty = 2.179874 \times 10^{-18} \text{ J}$$

$$R_\infty = 3.28984 \times 10^{15} \text{ Hz}$$

$$k = 1.38066 \times 10^{-23} \text{ J K}^{-1}$$

$$h = 6.62608 \times 10^{-34} \text{ J s}$$

$$m_e = 9.101939 \times 10^{-31} \text{ kg}$$

$$c = 2.99792 \times 10^8 \text{ m s}^{-1}$$

$$T(\text{K}) = T(\text{C}) + 273.15$$

$$F = 96,485 \text{ C / mol}$$

$$1 \text{ V} = 1 \text{ J / C}$$

Gas Constant:

$$R = 8.31451 \text{ J K}^{-1} \text{ mol}^{-1}$$

$$R = 8.20578 \times 10^{-2} \text{ L atm K}^{-1} \text{ mol}^{-1}$$

$$1 \text{ nm} = 10^{-9} \text{ m}$$

$$1 \text{ kJ} = 1000 \text{ J}$$

$$1 \text{ atm} = 760 \text{ mm Hg} = 760 \text{ torr} \approx 1 \text{ bar}$$

$$1 \text{ L atm} \approx 100 \text{ J}$$

Thermodynamics:

$$\Delta G^\circ = \Delta H^\circ - T\Delta S^\circ$$

$$\Delta H^\circ = \sum \Delta H^\circ_f(\text{products}) - \sum \Delta H^\circ_f(\text{reactants})$$

$$\Delta S^\circ = \sum S^\circ(\text{products}) - \sum S^\circ(\text{reactants})$$

$$\Delta G^\circ = \sum \Delta G^\circ_f(\text{products}) - \sum \Delta G^\circ_f(\text{reactants})$$

$$S = k_B \ln W$$

$$\Delta S = q_{\text{rev}} / T$$

$$\Delta E = q + w$$

$$w = -P_{\text{ext}} \Delta V$$

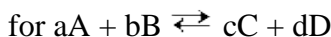

$$Q = \frac{[C]^c [D]^d}{[A]^a [B]^b} \quad \text{At equilibrium, } Q = K$$

$$\Delta G = \Delta G^\circ + RT \ln Q$$

$$G = G^\circ + RT \ln(a); a = \text{activity} = \gamma P / P^\circ \text{ or } \gamma[A] / [A]^\circ$$

$$\Delta G^\circ = -RT \ln K$$

$$\Delta G^\circ = -nF\Delta E^\circ$$

$$\Delta E = \Delta E^\circ - (RT/nF) \ln Q$$

$$\ln K = -\frac{\Delta H^\circ}{R} \frac{1}{T} + \frac{\Delta S^\circ}{R}$$

$$\Delta T = ik_{b,f} m$$

$$\Pi = iMRT$$

$$P_{\text{total}} = P_A + P_B = X_A P_A^\circ + X_B P_B^\circ$$

Acid Base:

$$\text{pH} = -\log[\text{H}_3\text{O}^+]$$

$$\text{pX} = -\log X$$

$$\text{pH} = \text{p}K_a + \log \frac{[A^-]}{[HA]}$$

Kinetics:

$$[A]_t = [A]_0 e^{-kt}$$

$$\ln[A]_t = \ln[A]_0 - kt$$

$$t_{1/2} = \ln 2 / k$$

$$1/[A]_t = 1/[A]_0 + kt$$

$$k = A e^{(-E_a/RT)}$$

$$\ln(k_1/k_2) = E_a/R (1/T_2 - 1/T_1)$$

$$t_{1/2} = 1/[A]_0 k$$

$$t_{1/2} = [A]_0 / kt$$

SECTION 1: ATOMS, MOLECULES AND MOLES

1. The complete combustion of liquid propyl alcohol (C_3H_7OH) in oxygen yields just carbon dioxide and water. When this reaction is balanced using smallest integer coefficients, the coefficient for O_2 is

- A. 5
- B. 9
- C. 10
- D. 20
- E. none of these

ANS: B

2. The ratio of the number of bismuth atoms to the number of oxygen atoms in $Bi_2(SO_4)_3$ is

- A. 1:6
- B. 2:7
- C. 2:3
- D. 2:1
- E. none of these

ANS: A

3. A ternary compound contains one atom of scandium and three atoms of nitrogen for every nine atoms of oxygen. A possible formula for the compound is

- A. $Sc(NO_3)_3$
- B. $Sc_2(N_2O_3)_3$
- C. $Sc(NO_2)_4$
- D. $Sc(NO_4)_3$
- E. none of these

ANS: A

4. Assume that the following reaction between phosphorus and chlorine gas goes as far as possible to give the product, gaseous phosphorus pentachloride.

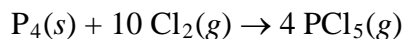

If 0.231 mol of P_4 is reacted with an excess of Cl_2 , how much PCl_5 will be produced?

- A. 0.231 mol
- B. 0.462 mol
- C. 0.693 mol
- D. 0.924 mol
- E. none of these

ANS: D

5. An unknown mass of element A reacts with 1.811 g of element B and 3.613 g of element C to produce 7.124 g of a compound containing A, B, and C. Assuming all reactants are consumed, what additional information is required in order to calculate the unknown mass of A?

- A. a balanced equation for the reaction
- B. the molar masses of A, B and C
- C. the formula of the reaction product
- D. All of the above are required.
- E. None of the above is required.

ANS: E

6. The mass number of an atom indicates

- A. the number of electrons in the atom.
- B. the number of protons in the atom.
- C. the number of neutrons in the atom.
- D. the sum of the numbers of protons and electrons in the atom.
- E. the sum of the numbers of neutrons, protons and electrons in the atom.

ANS: E

EVERYONE was credited 3 points for this question regardless of the answer.

There is a severe omission/simplification in the TRO 2nd ed. textbook. On page 56 it states correctly that $A = \text{number of protons (p)} + \text{neutrons (n)}$. A is called the nucleon number or the number of nucleons, it is not the atomic mass at all. The atomic mass is the mass of the nucleons plus the mass of the electrons. That is why A is always a whole number, whereas the atomic mass will not be an integer value, but a non-integer value. I will contact Professor Tro and the Mastering Chemistry staff to have this corrected in the next edition of the book.

7. How many electrons does the species $^{57}\text{Fe}^{3+}$ have?

- A. 23
- B. 26
- C. 29
- D. 54
- E. none of these

ANS: A

8. A single atom of an unknown element has a mass of 2.339824×10^{-22} g. Assuming that the element has only one naturally occurring isotope, the element must be

- A. La
- B. Ce
- C. Pr
- D. Nd
- E. none of these

ANS: C

9. The combustion products of a hydrocarbon with which empirical formula yield the following mass spectrum?

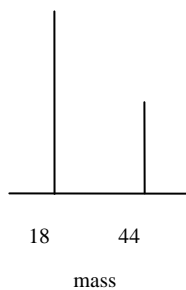

- A. C₄H
 - B. C₂H
 - C. CH
 - D. CH₂
 - E. CH₄
- ANS: E

10. An equimolar mixture of oxygen atomic isotopes forms oxygen molecules. Which is the correct O₂ spectrum?

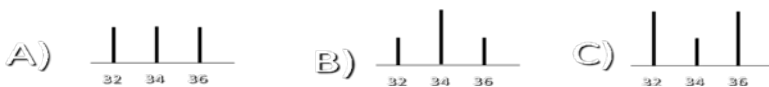
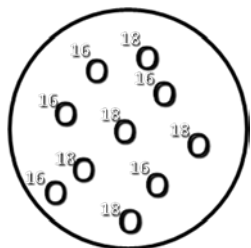

ANS: B

11. The empirical formula for a hydrocarbon is found to be CH₂. In a separate experiment, the molar mass is determined to be approximately 112 g mol⁻¹. The number of hydrogens in the molecular formula of the hydrocarbon is therefore

- A. 8
 - B. 12
 - C. 16
 - D. 20
 - E. none of these
- ANS: C

SECTION 2: PROPERTIES OF PARTICLES AND LIGHT

Consider the two slit interference on a screen experiment shown below for questions 12-15.

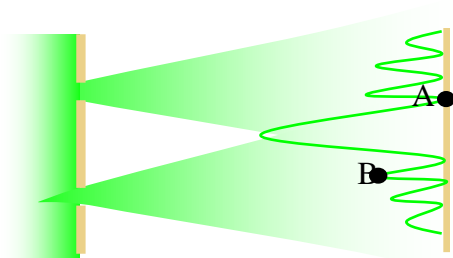

12. Which is true around point B for an experiment with light (mark all that apply)?

- A. Constructive interference occurs.
- B. Destructive interference occurs.
- C. The light on the screen is relatively bright.
- D. The light on the screen is relatively dim/dark.
- E. None of these.

ANS: A and C

13. Which is true around point A for an experiment with electrons (mark all that apply) ?

- A. Constructive interference occurs.
- B. Destructive interference occurs.
- C. The probability of electron impact is high.
- D. The probability of electron impact is low.
- E. None of these.

ANS: B and D

14. Which is true for a two slit experiment with baseballs (mark all that apply)?

- A. Constructive interference occurs.
- B. Destructive interference occurs.
- C. The probability of baseball impacts follows the light example.
- D. The probability of baseball impacts follows the electron example.
- E. None of these.

ANS: E

15. Which is true for an experiment with light of a lower frequency (with the same intensity. Mark all that apply)?

- A. Photon wavelengths increase.
- B. The distance between bright spots increases
- C. More photons strike the screen per second.
- D. The amplitude of the wave pattern decreases.
- E. None of these.

ANS: A and B.

16. Which is the best description of the color of an object with the following absorption spectrum?

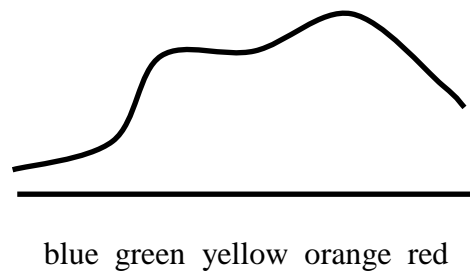

- A. yellow
- B. red
- C. orange
- D. white
- E. blue

17. To which energy level scheme does the emission spectrum correspond?



- A) B) C)

ANS: B

18. Red light has a _____ frequency and a _____ wavelength than blue light.

- A. higher, longer
- B. lower, longer
- C. higher, shorter
- D. lower, shorter

ANS: B

19. Light of wavelength 1000 nm is in the _____ region of the electromagnetic spectrum.

- A. infrared

- B. microwave
- C. ultraviolet
- D. x-ray
- E. visible

ANS: A

20. Blue, red, yellow and green light eject electrons from the surface of potassium. In which case do the ejected electrons have the highest average kinetic energy?

- A. blue
- B. red
- C. yellow
- D. green
- E. they all eject electrons of the same average kinetic energy

ANS: A

21. A photon of blue light (400 nm) is absorbed and 2 photons are emitted as illustrated in the energy diagram below. To which color light do the two equivalent emitted photons correspond?

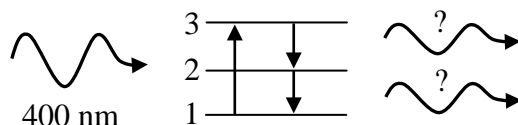

- A. IR
- B. Yellow
- C. Green
- D. Blue
- E. UV

ANS: A

22. Calculate the energy of a photon of light having a frequency of $8.927 \times 10^{14} \text{ s}^{-1}$.

- A. $7.423 \times 10^{-49} \text{ J}$
- B. $5.915 \times 10^{-19} \text{ J}$
- C. $5.915 \times 10^{-12} \text{ J}$
- D. $1.347 \times 10^{14} \text{ J}$
- E. none of these

ANS: B

23. How many photons are contained in a flash of green light (525 nm) that contains 189 kJ of energy?

- A. 5.67×10^{23} photons
- B. 2.01×10^{24} photons
- C. 1.25×10^{31} photons
- D. 4.99×10^{23} photons

E. 7.99×10^{30} photons

ANS: D

24. Determine the energy of 1 mol of photons for visible light of 500 nm.

A. 239 kJ

B. 3.98×10^{-19} J

C. 5.98×10^{-7} J

D. 6.02×10^{23}

E. 300 J

ANS: A

SECTION 3: QUANTUM MECHANICS

25. What is the de Broglie wavelength of a 143 g baseball traveling at 95 mph (1 mile = 1.609 km).

- A. 1.1×10^{-34} m
- B. 5.5×10^{-33} m
- C. 1.4×10^{-23} m
- D. 2600 m
- E. 39 m

ANS: A

26. Light of 450 nm wavelength will eject electrons from a metal sample. Which also must be true?

- A. Light of 500 nm will also eject electrons.
- B. Light of 400 nm will also eject electrons.
- C. 450 nm light of greater intensity will eject electrons with greater kinetic energy.
- D. 600 nm light will eject electrons provided the intensity is great enough.
- E. None are true.

ANS: B

27. In the photoelectric effect, light directed onto the surface of metal in a vacuum causes electrons to be ejected. As the intensity of the light increases,

- A. the kinetic energy of the ejected electrons increases.
- B. the kinetic energy of the ejected electrons decreases.
- C. the number of ejected electrons increases.
- D. the number of ejected electrons decreases.
- E. none of these, because the number and energy of the ejected electrons is independent of intensity.

ANS: C

28. Light of wavelength 400 nm strikes a clean surface of metallic Cs in vacuum and ejects an electron having kinetic energy 1.54×10^{-19} J. Calculate the de Broglie wavelength of this electron.

- A. 1.25 nm
- B. 400 nm
- C. 579 nm
- D. 1290 nm
- E. 4.72×10^{15} nm

ANS: A

29. The de Broglie wavelength of an electron moving with velocity 1.00×10^6 m s⁻¹ is 7.27 Å. Therefore, to achieve a de Broglie wavelength of 5.00 Å, an electron must move with velocity

- A. 4.73×10^5 m s⁻¹
- B. 6.88×10^5 m s⁻¹
- C. 1.45×10^6 m s⁻¹
- D. 2.11×10^6 m s⁻¹
- E. none of these

ANS: C

30. Calculate the wavelength of light emitted when the electron in a hydrogen atom undergoes a transition from $n = 4$ to $n = 3$.

A. 1.060×10^{-19} nm

B. 1.094×10^{-6} nm

C. 91.13 nm

D. 1094 nm

E. 1875 nm

ANS: E

31. When a gaseous magnesium ion gains an electron to become a gaseous magnesium atom, does it absorb or release energy?

A. absorb

B. release

ANS: B

32. It requires 2.08×10^{-18} J to eject an electron from one atom of Cl. If you shine light that has an energy of 5.20×10^{-18} J on one Cl atom, how much kinetic energy would you expect the electron to have?

A. 3.12×10^{-18} J

B. 7.28×10^{-18} J

C. 0 J

D. -3.12×10^{-18} J

E. -7.28×10^{-18} J

ANS: A

Consider the following diagram showing the energy levels of **one** Hydrogen atom for the following questions 33 - 37.

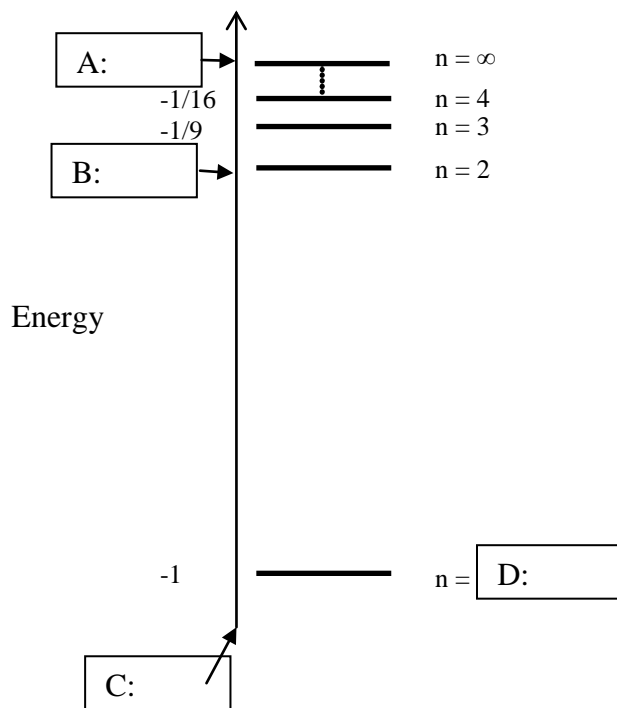

33. In what units is the energy expressed?

- A. Joules
- B. Kilojoules
- C. Hertz (frequency)
- D. Rydbergs
- E. Kelvins

ANS: D

34. Which value belongs in box A?

- A. -1
- B. $-1/4$
- C. 0
- D. 1
- E. none of these

ANS: C

35. Which value belongs in box B?

- A. -1
- B. $-1/4$
- C. 0

- D. 1
- E. none of these

ANS: B

36. Which value belongs in box C?

- A. -1
- B. -1/4
- C. 0
- D. 1
- E. none of these

ANS: E

37. Which value belongs in box D?

- A. -1
- B. -1/4
- C. 0
- D. 1
- E. none of these

ANS: D

38. Which set of quantum numbers is not possible (mark all that apply)?

- A. $n = 1, \ell = 0, m_\ell = 1$
- B. $n = 2, \ell = 0, m_\ell = 0$
- C. $n = 3, \ell = 3, m_\ell = 1$
- D. $n = 4, \ell = 0, m_\ell = 1$
- E. $n = 5, \ell = 4, m_\ell = 4$

ANS: A, C, D

SECTION 4: LABORATORY

39. The requirements for the airbag that you developed in the first lab were that it could be deployed at a given time and that it inflates to the largest possible volume. The constraints on the airbag design were that it could not weigh more than 3.5 g and you could only use the materials available. The chemical reaction that you used to produce the gas (CO₂) was:



If you are given an apparatus design that weighs 1.95 g (without the addition of the reaction chemicals); what is the maximum amount of CO₂ that you can produce at 0°C? You can assume that the concentration of CH₃COOH is 100%. The molar volume of CO₂ at this condition is 22.4 L.

- A. 240 mL
- B. 650 mL
- C. 11 mL
- D. 904 mL
- E. 470 mL

ANS: A

40. When estimating the number of stearic acid molecules in the monolayer in the experiment “Determination of Avogadro’s number”, which of the following is not needed for calculation?

- A. the diameter of the watch glass
- B. total volume of stearic acid solution in test tube before rinsing the dropper pipette
- C. the number of drops of stearic acid required to form the monolayer
- D. molecular geometry of stearic acid

ANS: B and C

EVERYONE was credited 3 points for this question regardless of the answer.

The question should have specified “Mark all that apply.”

