

Name: _____

UNIVERSITY OF CALIFORNIA
College of Engineering
Department of Electrical Engineering
and Computer Sciences

Professor David Tse

EECS 121 — FINAL EXAM

21 May 1997, 5:00-8:00 p.m.

Please write answers on blank pages only. Answer all 5 questions. Clear justifications of answers are needed.

Problem 1 (20 points) — True or False

Please explain fully. Answers without explanations will get no marks.

- a) If E_1 and E_2 are two events, then $P(E_1 \cup E_2) \leq P(E_1) + P(E_2)$ **only** if E_1 and E_2 are independent.
- b) We have a channel bandlimited to $[-W, W]$, and want to design a transmit filter such that we have controlled ISI only at the adjacent symbol (no ISI at all other symbols). It may still be possible to do this when the symbol rate $\frac{1}{T} > 2W$.
- c) QAM with high constellation size is a suitable modulation scheme to use for deep-space communication.
- d) Consider the transmission of binary PAM over a channel with known ISI, followed by a matched filter and a sampler at symbol rate. One can design a MMSE equalizer in conjunction with a symbol-by-symbol detector that outperforms a sequence detector based on Viterbi's algorithm, in terms of probability of detection error.
- e) Non-coherent demodulation of DPSK (differential phase-shift keying) results in the same probability of detection error as coherent demodulation of PSK.

Problem 2 (20 points)

Consider an M -ary FSK (frequency-shift keying) modulation scheme:

$$S_m(t) = \sqrt{\frac{2E_s}{T}} \cos[2\pi(f_c + m\Delta)t]$$
$$0 \leq t \leq T$$

where T is the symbol period, f_c is the carrier frequency, and Δ is the frequency separation.

[4 pts.] a) Choose a Δ such that the signals are all orthogonal. Verify that they are.

[6 pts.] b) Design an optimal **coherent** demodulation and detection scheme, assuming perfect phase estimates.

[5 pts.] c) Derive an expression for the probability of detection error.

[5 pts.] d) Derive a union bound for the probability of error.

Problem 3 (20 points)

Consider a channel with ISI, with impulse response: $h(t) = \delta(t) + \delta\left(t - \frac{T}{2}\right)$. Transmission is done via binary PAM with transmit filter $g_T(t)$. The receiver is composed of a matched filter followed by a symbol-rate equalizer followed by a symbol-by-symbol detector.

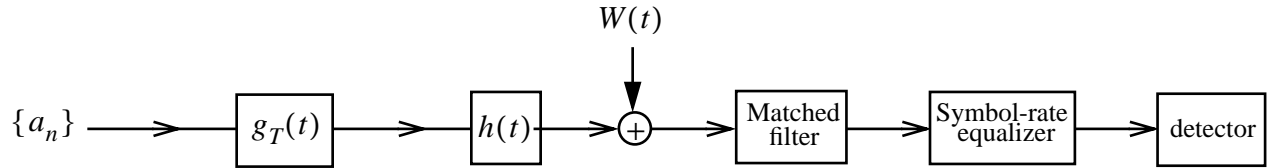

The symbols in the information sequence $\{a_n\}$ are assumed to be independent and equally likely to be 1 or -1 .

[10 pts.] a) Design a zero-forcing linear equalizer to cancel the effects of the ISI. Does it depend on the statistics of the information sequence?

[10 pts.] b) Design a 2-tap MMSE linear equalizer. Does it depend on the statistics of the information sequence?

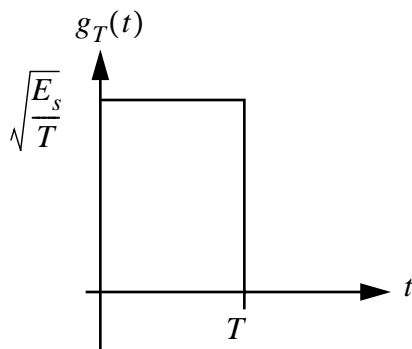

Problem 4 (20 points)

In class we studied the Miller code which is an example of a run length-limited code. In this problem, we will look at another code, which is an example of an *error-correcting convolutional* code.

The informational sequence $\{a_n\}$ is a sequence of equally likely 0's and 1's. The coded sequence $\{b_m\}$ is given by

$$\begin{aligned} b_{2n} &= a_n \oplus a_{n-2} & n = 0, 1, 2, \dots \\ b_{2n+1} &= a_n \oplus a_{n-1} \end{aligned}$$

where \oplus is addition mod 2. The symbol sequence $\{b_m\}$ is transmitted over an AWGN channel using antipodal PAM at symbol rate $\frac{1}{T}$.

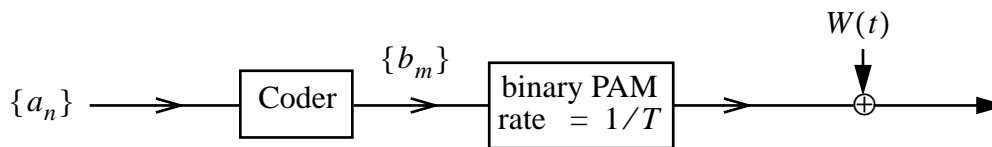

[3 pts.] a) Consider as an example the information sequence $(\{a_n\}) \{0, 1, 1, 0, 0\}$. Find the corresponding coded sequence $\{b_m\}$. (Assume that $a_k = 0$ for $k < 0$). What is the length of the coded sequence?

[3 pts.] b) What is the **rate** at which information bits is transmitted over the channel?

We now want to design a detector for the information sequence $\{a_n\}$.

[4 pts.] c) Recall that for the Miller code, the previous information bit serves as the state of the system. What can be used as the state for this problem? How large is the state space? Enumerate all possible states.

[5 pts.] d) Draw the trellis, with each stage of the trellis corresponding to an information bit transmitted.

[5 pts.] e) Using the trellis or otherwise, describe as clearly as possible how optimal detection of the information sequence $\{a_n\}$ can be done at the receiver.

Problem 5 (20 points)

Consider a multiple-access communication system, with two transmitters and one receiver. Both transmitters use binary PAM. Let $g_T(t)$ be a rectangular transmit pulse. Sender A uses the pulse $g_T(t)$, and sender B uses the pulse $g_T(t - T)$. At time 0, sender A transmit symbol X and sender B transmits symbol Y , where X and Y are independent and equally likely to be 1 or -1 . The overall transmitted signal is: $U(t) = Xg_T(t) + Yg_T(t - T)$.

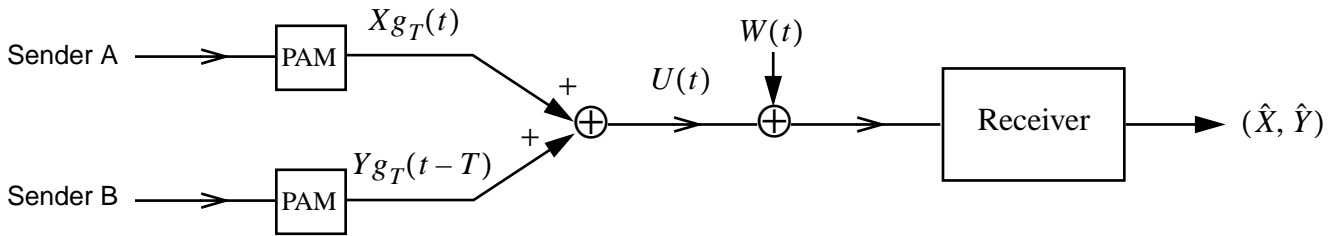
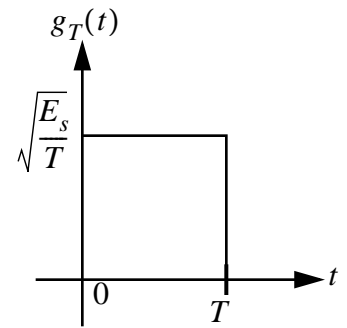

The received signal is $U(t) + W(t)$ where $\{W(t)\}$ is independent AWGN with power spectral density $\frac{N_0}{2}$.

[7 pts.] a) Design a maximum likelihood receiver for estimating the pair of transmitted symbols (X, Y) .

Now suppose due to problems of synchronization between the two senders, the transmitted pulses overlap. Specifically, the overall transmitted signal is now

$$U(t) = Xg_T(t) + Yg_T(t - T + \alpha T)$$

where $0 < \alpha < 1$ gives the fraction of time of overlap.

[6 pts.] b) Assuming that the receiver maintains perfect synchronization with both senders, we plan to use the following receiver structure:

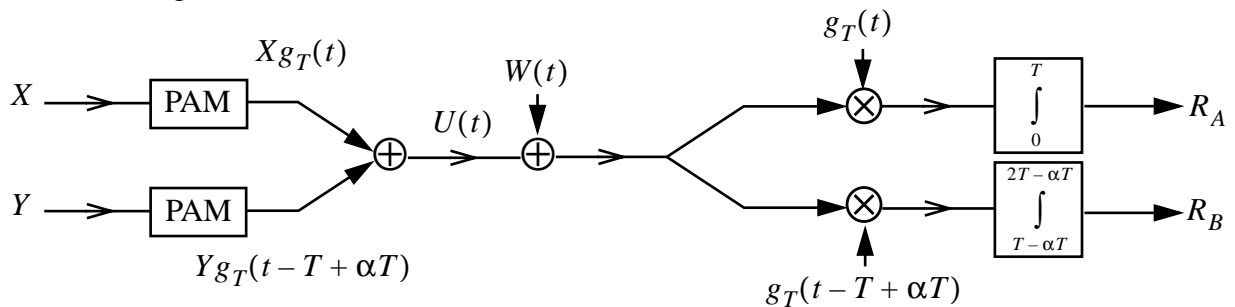

and decide $X = 1$ if $R_A \geq 0$, $X = -1$ if $R_A < 0$. Similarly we decide $Y = 1$ if $R_B \geq 0$ and $Y = -1$ if $R_B < 0$. Compute the probabilities of detection error for both X and Y (i.e., $P(\hat{X} \neq X)$ and $P(\hat{Y} \neq Y)$).

[7 pts.] c) Does the above scheme minimize the probabilities of detection error of the pair (X, Y) (i.e., $P((\hat{X}, \hat{Y}) \neq (X, Y))$)? Explain. If not, design one that does. (Hint: Are the signal waveforms of the two senders orthogonal?)