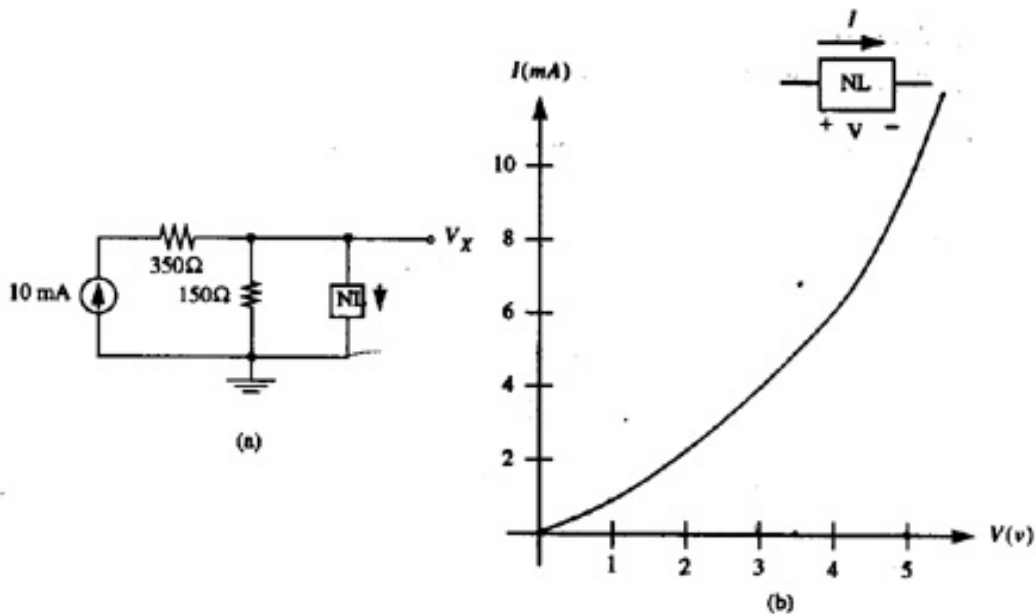
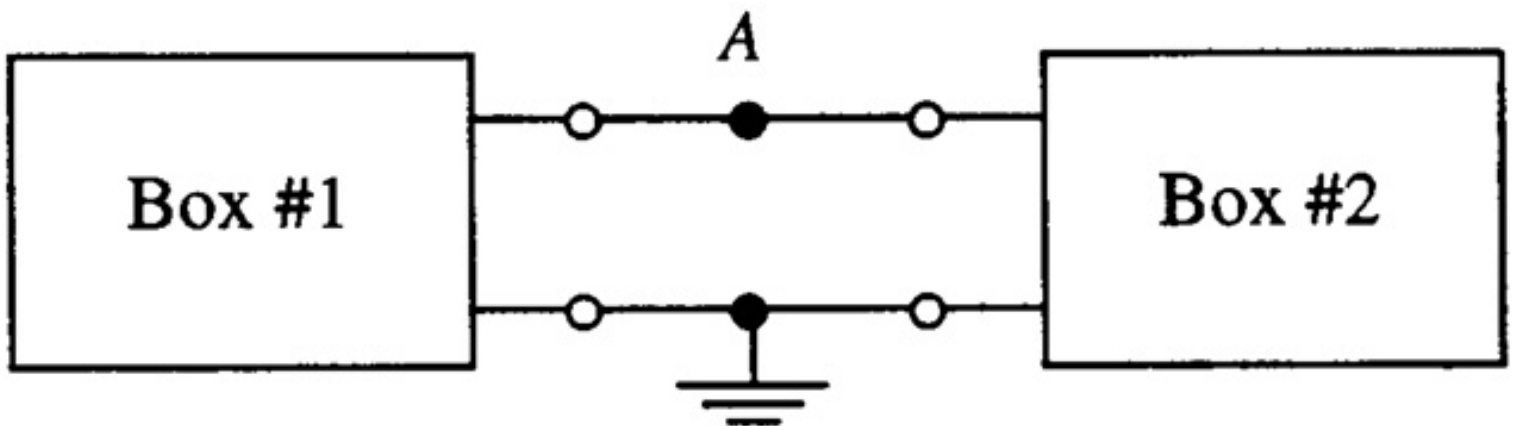

EE40 Spring 1998
Midterm #1
S. Schwarz, R. M. White

Problem #1

The nonlinear circuit element NL in Fig. (a) has the I-V characteristic shown in (b). (Sign conventions for V , I are as shown.) Find V_x with respect to ground.

Problem #2

Box #1 is represented by a Thevenin equivalent with $V_{T1} = 5V$, $R_{T1} = 3000$ ohms. For Box #2, $V_{T2} = -6V$, $R_{T2} = 2000$ ohms. The two boxes are connected together as shown.

a) Find the voltage at node A with respect to ground.

b) Find the power flow (in watts) between the boxes, in the direction from Box 1 into Box #2.

Problem #3

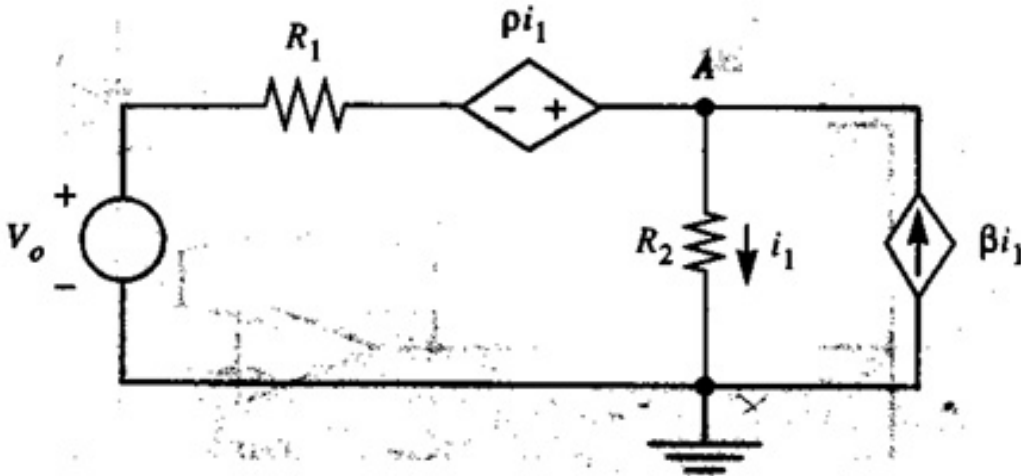

In the above circuit $V_o = 10\text{V}$, $R_1 = 1000\text{ ohms}$, $R_2 = 2000\text{ ohms}$, $\rho = 5000$, $\beta = 0.7$. Find the voltage at node A with respect to ground. (For ease of grading, please write equations using letter symbols, solve the equations, and then substitute numerical values as the final step.)

Problem #4

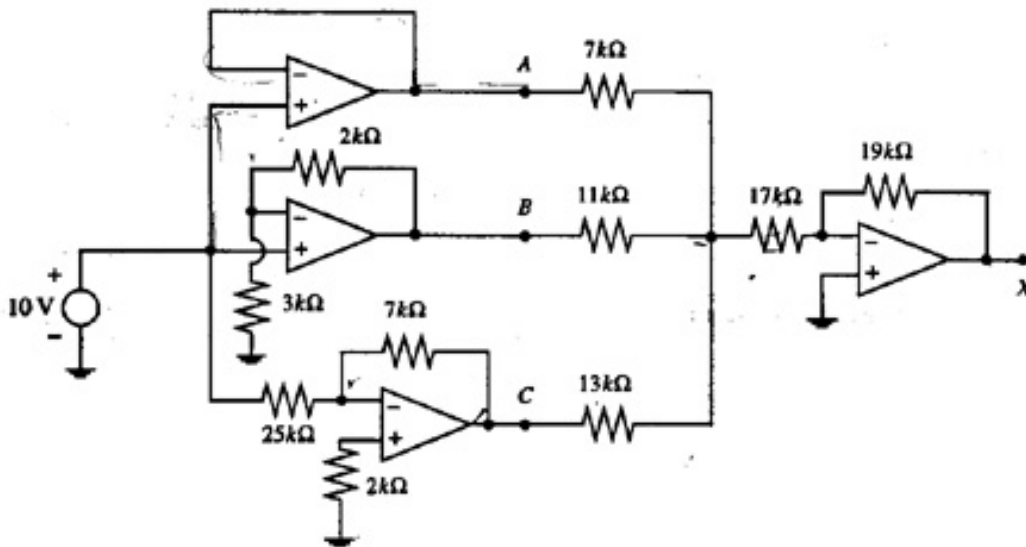

In the above circuit all the op-amps are "ideal".

a) Find V_a (the voltage at node A with respect to ground):

b) Find V_b :

c) Find V_c :

d) Find V_d :

Posted by HKN (Electrical Engineering and Computer Science Honor Society)

University of California at Berkeley

**If you have any questions about these online exams
please contact <mailto:examfile@hkn.eecs.berkeley.edu>**