

University of California at Berkeley
College of Engineering
Dept. of Electrical Engineering and Computer Sciences

EECS 40 Midterm I

Fall 1998

Prof. Roger T. Howe

October 1, 1998

Name: _____
Last, first

Student ID _____

Guidelines

1. Closed book and notes; one 8.5" x 11" page (both sides) of your own notes is allowed.
2. You may use a calculator.
3. Do not unstaple the exam.
4. Show *all your work and reasoning on the exam* in order to receive full or partial credit.

Score

Problem	Points Possible	Score
1	17	
2	17	
3	16	
Total	50	

1. Space Station Power Supply [16 points]

After finishing your B.S. in EECS, you find Silicon Valley too boring and go to work for NASA on the 2010 Space Station project. Your first assignment is to specify the power cable connecting the solar cell panels to one part of the living quarters. The circuit is completed through the frame of the cabin. Note that “ground” is not conveniently located nearby!

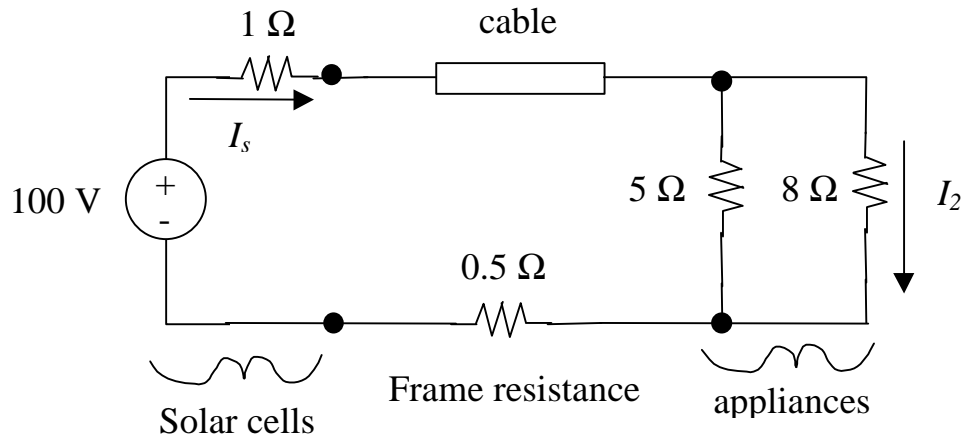

(a) [4 pts.] We would like to make the cable resistance the same as the frame resistance: $R_{\text{cable}} = 0.5 \Omega$. The cable is 10 m in length and is made of aluminum. Given that the resistivity of aluminum is $\rho = 2.7 \mu\Omega\text{-cm}$, what is the diameter of the cable in mm?

(b) [4 pts.] Noting that the cable resistance $R_{\text{cable}} = 0.5 \Omega$, what is the current I_s in A? Note that there is no need to have solved part (a).

(c) [4 pts.] What is the value of the current I_2 in A through the $8\ \Omega$ resistor?

(d) [5 pts.] A battery (modeled by an $75\ \text{V}$ voltage source in series with a $2\ \Omega$ internal resistance in the circuit below) is used to back up the solar cells. What is the power absorbed in W by the battery?

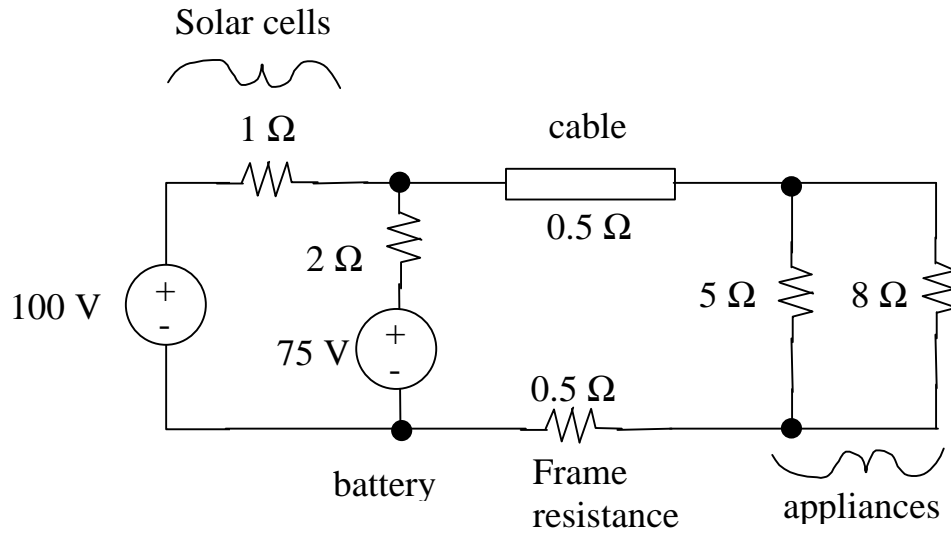

2. Two-Terminal Networks [17 points]

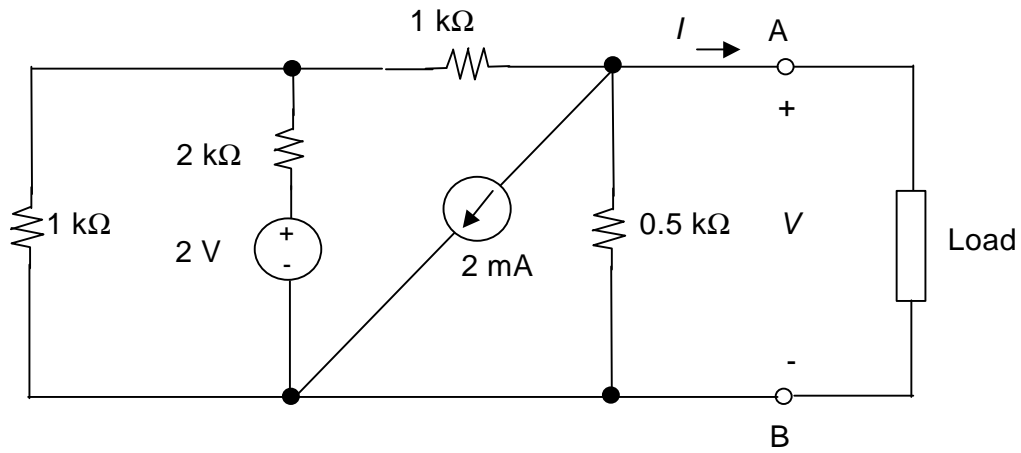

(a) [4 pts.] Find the numerical value of the Thevenin resistance R_{Th} between nodes A and B.

(b) [5 pts.] Find the numerical value of the short-circuit current I_{sc} in mA between nodes A and B.

- (c) [4 pts.] Find the numerical value of the open-circuit voltage V_{oc} in volts. If you couldn't solve parts (a) and (b), you can use the following information without loss of credit: $I = 3 \text{ mA}$ when $V = 0.5 \text{ V}$ and $I = 0.25 \text{ mA}$ when $V = 1 \text{ V}$.
(note that these values are not correct answers for this circuit.)

- (d) [4 pts.] Plot the I vs. V relationship for this two-terminal element on the graph below. If you couldn't solve parts (a), (b), or (c), you can use the default information from part (c) in this part.

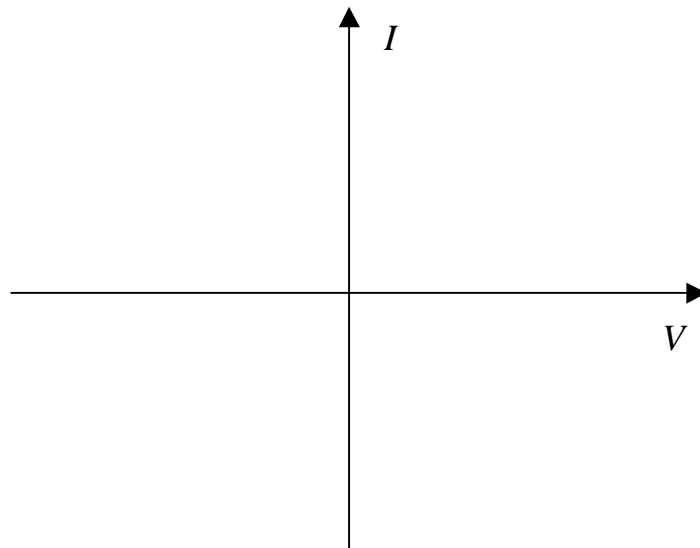

3. Linear Resistive Networks [16 points]

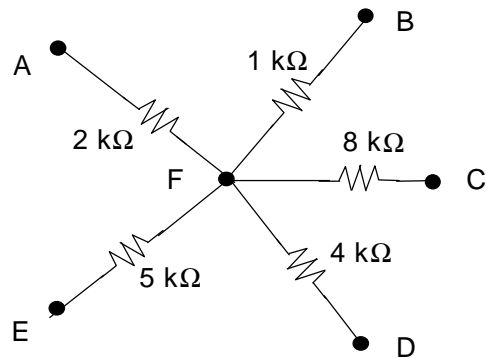

(a) [5 pts.] Nodes A, B, C, D, and E are connected to a 5 V supply. A current source with value $I = 2\text{mA}$ is connected between nodes F and E (current reference direction is positive into node F). What is the voltage at node F?

(b) [6 pts.] The voltage source shown below is connected to node A with nodes B, C, D, and E connected to the reference node. What is the voltage at node F?

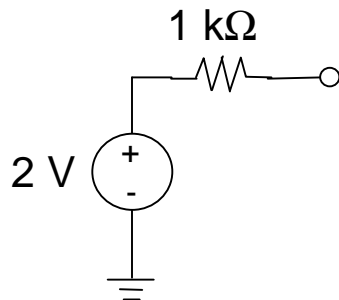

(c) [5 pts.] A voltage source of value 3 V is connected between nodes B and E (with B the positive reference); nodes C, D, and E are connected together. Find the Norton equivalent circuit between nodes A and E, with A the positive reference.