

UNIVERSITY OF CALIFORNIA
Electrical Engineering and Computer Sciences

145L MIDTERM #2 (take-home)
November 7, 1994

Due Monday, November 14, 1994

(100 points total, 3 points deducted for each school day late)
(No credit after graded midterms have been returned to students) (Nov 21)

PROBLEM 1 (15 points)

A project requires an op-amp circuit with a gain of 100 from d.c. to 100 kHz (Figure 1). Assume that an FET input op-amp is used, similar to the LF356 that you used in Laboratory Exercise 4.

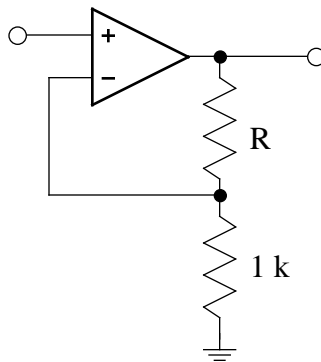

Figure 1 Non-inverting amplifier op amp circuit.

- What is the value of R in your design?
- For an open loop gain A that varies inversely with frequency f as $A = B/f$, derive an expression for the closed loop gain G as a function of the constant B and the frequency f .
- For $B = 10^7$ Hz, sketch the closed loop gain vs. frequency (Bode plot).
- At what frequency does the closed loop gain G equal unity?
- What are typical input and output impedances of this circuit at 1 kHz and 100 kHz? (Hint: look at the LF156/LF356 data sheets at the back of the 145L Course Reader.)

PROBLEM 2 (20 points)

You are designing a thermocouple-based system for measuring the temperature of a furnace over the temperature range from 25 °C to 500 °C with an absolute accuracy of 2 °C and do not want to provide ice to stabilize the temperature of the reference junction at 0 °C. Instead, you decide to leave the reference junction in the air of the room and measure the temperature of the room (maximum range 10 to 45 °C) with a thermistor, which would provide sufficient accuracy. The correction of the thermocouple output for room temperature will be done by a microcomputer program.

- Design a circuit that converts the thermocouple output into a suitable voltage V_{TC} (-5 to +5 volts) for input to a microcomputer. Draw a block diagram and label all

- necessary analog circuit elements and signal lines. Include the thermocouple wires. (It is not necessary to include analog filtering)
- Design a circuit that converts the thermistor resistance into a suitable voltage V_{tm} (-5 to +5 volts) for input to a microcomputer. Draw a block diagram and label all necessary analog circuit elements and signal lines. Show where the thermistor is placed in the diagram of part a. above. (It is not necessary to include analog filtering)
 - Sketch the thermocouple voltage V_{tc} as a function of the temperature difference $T = T_{sens} - T_{ref}$. Label the axes with numbers and units.
 - Sketch the thermistor voltage V_{tm} as a function of the thermistor temperature T_{tm} . Label the axes with numbers and units.
 - Describe what the microcomputer program would have to do to convert V_{tc} and V_{tm} into the temperature T_{sens} of the sensing junction in the furnace.

PROBLEM 3 (15 points)

You wish to measure air temperatures over the 0°C to 50°C temperature range using the thermistor bridge shown in Figure 2 with $R_2 = R_3 = 1\text{ k}$. The bridge output is amplified by an instrumentation amplifier with a gain of 5. In this problem we investigate the thermal dissipation constant of the thermistor.

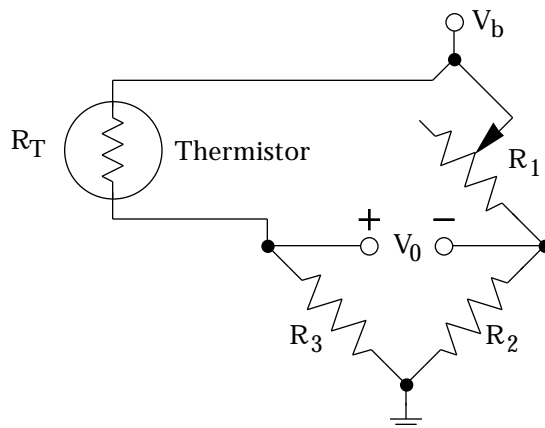

Figure 2 Thermistor in bridge circuit. Variable resistor R_1 may be adjusted to produce a zero output voltage at a selected temperature.

The thermistor has the following relationship between temperature and resistance:

T	R_T	T	R_T
0°C	2 k	10°C	1.33 k
20°C	1 k	30°C	667
40°C	500	50°C	333

With the thermistor in air and a bias voltage $V_b = 1$ volt, you adjust R_1 to make $V_0 = 0.00$ volts.

Increasing the bias voltage to $V_b = 10$ volts, and after waiting for the thermistor temperature to stabilize, you measure $V_0 = 5.00$ volts.

- What are the thermistor resistances at these two bias voltages?
- What are the thermistor temperatures at these two bias voltages?
- What power is dissipated by the thermistor at $V_b = 1$ volt?
- What power is dissipated by the thermistor at $V_b = 10$ volts?

- e. What is the thermal dissipation constant for the thermistor in air?
- f. Comment on the best bias voltage for this application.

PROBLEM 4 (25 points)

You have just been hired to help test a new type of large windmill. Large windmills generate considerable power at high wind speed, but their blades can be destroyed if the wind speed becomes too great. Your job is to instrument a test windmill so that you can measure the backward bending of the moving blades and determine whether the wind speed is within safe limits (Figure 3). At dangerous wind speeds, the windmill can be “shut down” by rotating the generator housing 90° on a vertical axis so that the wind strikes the blades from the side.

Assume the following:

- You have decided to use metal foil strain gauges with gauge factor $G = 2$ (similar to those used in the 145L lab)
- You have decided to mount the strain gauges, necessary electronics, and a small, rugged radio transmitter on the moving blade and to transmit the information to a radio receiver on the ground.
- The radio transmitter can accept signals in the -10 to $+10$ volt range and the radio receiver reproduces the transmitted signal with the same amplitude.
- The radio system has a frequency response 0 Hz to 10 kHz, and adds 10 mV of white noise in this frequency band.

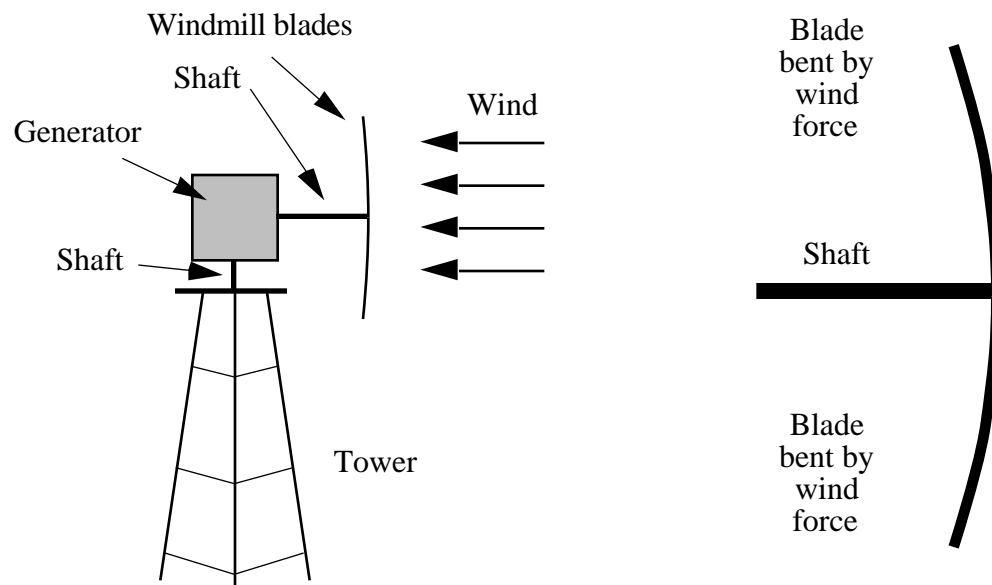

Figure 3 Windmill to be instrumented with strain gauges to determine whether the wind speed is within safe limits.

Design a system that senses the backward bending of the wind on the moving blade, transmits the signal to a radio receiver on the ground, and interfaces the signal to a microcomputer.

- Your design should reject noise outside of the 0 - 100 Hz frequency band of interest
- Your design should compensate for temperature variations

- Sketch where you would attach the strain gauges and other components to the blade.
- Draw a block diagram of your system, showing and labeling all essential components and connecting wires both on the blade and on the ground.
- Show on your block diagram above the voltages that would occur for a strain $|\Delta L/L| = 0.1\%$.

PROBLEM 5 (25 points)

A test kit is available for measuring the levels of lead in eating utensils (cups, bowls, plates, etc.). The utensil is first soaked in hot acetic acid (vinegar) and the acid is mixed with a reagent. If no lead is present, the mixture is clear. If a small amount of lead is present, the mixture is yellow. If a dangerous amount of lead is present, the mixture is dark orange.

Design a system for determining the concentration of lead in ppm, using a green LED, a photodiode, and a microcomputer with A/D converter (input range -10 volts to $+10$ volts). (It is not necessary to include analog filtering)

Assume the following:

- The light intensity A passing through the solution is given by $A = A_0 e^{-kLC}$, where C is the lead concentration in ppm, L is the thickness of the solution in cm, and the extinction coefficient for green light is $k = 1 \text{ ppm}^{-1} \text{ cm}^{-1}$.
 - The thickness of the solution is $L = 1 \text{ cm}$.
 - The brightness of the LED is such that a clear solution produces a current of $100 \mu\text{A}$ in the photodiode and your design should convert this into a signal of 5 volts at the A/D converter of the microcomputer.
 - The entire system has a measured noise level of 10 mV rms at the A/D converter.
 - The amplifier offset output voltage is V_B .
 - You operate the photodiode in photovoltaic mode.
- Sketch a block diagram including and labeling all essential components. (You can show the A/D and microcomputer as a single block).
 - Derive an expression for the A/D input voltage as a function of lead concentration C , dark current I_D , and amplifier output offset V_B .
 - Describe how a user would calibrate the system.
 - Derive an expression for the uncertainty ΔC as a function of concentration C .
[Hint: $\Delta C = \Delta I / (dI/dC)$]
 - What is the uncertainty ΔC at $C = 0.1 \text{ ppm}$, 1 ppm , and 3 ppm ?
 - What is the lowest and highest concentrations of lead that you can reliably measure? (Hint: find the two values of concentration C at which $\Delta C = C$)