

**EE 145L Electronic Transducer Lab**  
**Midterm #2 (100 points maximum)**  
**(closed book, calculators OK - note formulas on last page)**  
**(You will not receive full credit if you do not show your work)**

**PROBLEM 1 (45 points)**

You wish to measure air temperatures over the range from  $0^{\circ}\text{C}$  to  $50^{\circ}\text{C}$  using the thermistor bridge shown below.

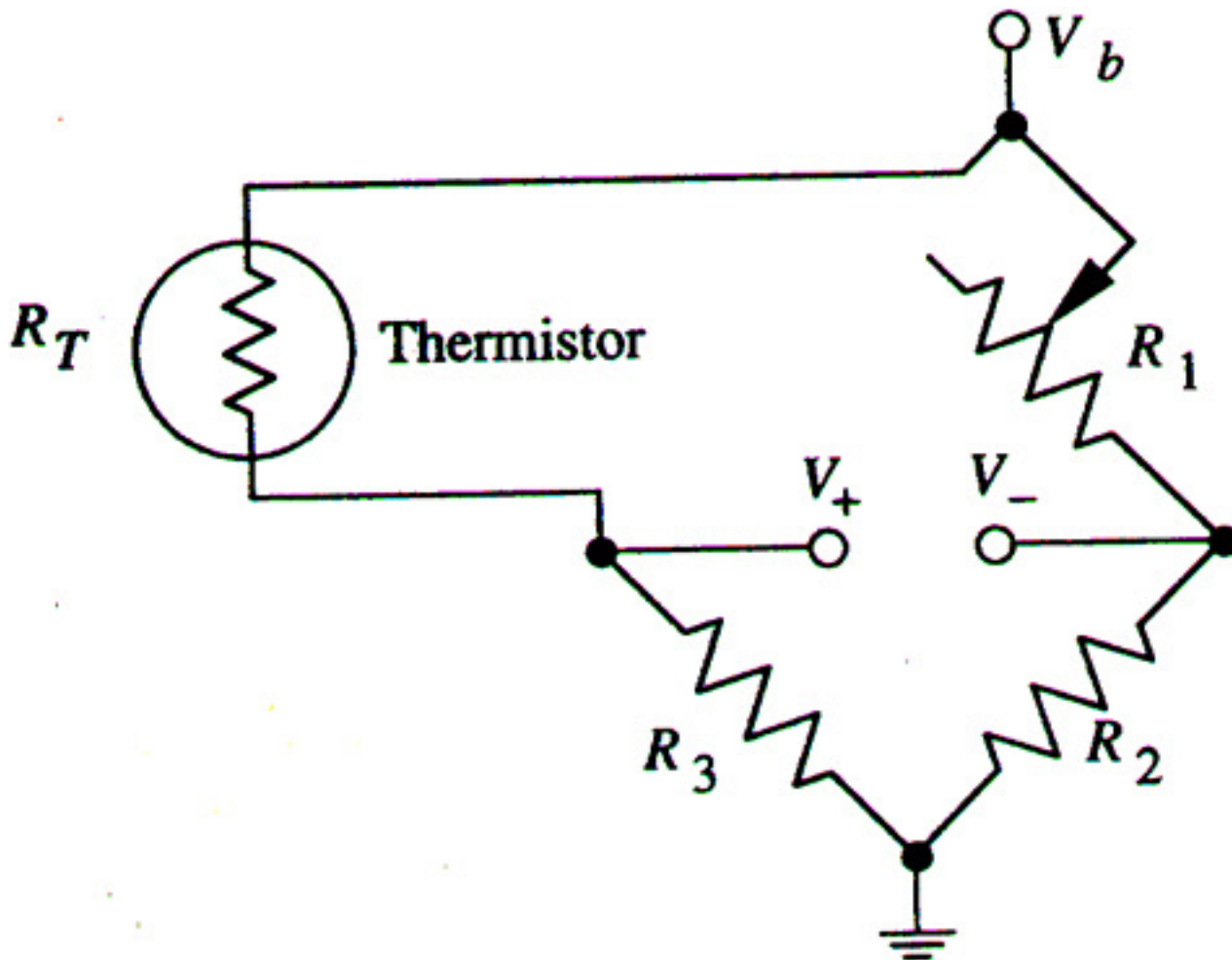

**Assume the following:**

- $R_2 = R_3 = 5k$  Ohms
- You use an instrumentation amplifier with a gain of 5:  $V_0 = 5 (V_+ - V_-)$
- The thermistor resistance  $R_T$  vs. temperature  $T$  as shown in the table below.

0°C	10°C	20°C	30°C	40°C	50°C
10.000k Ohms	6.667k Ohms	5.000k Ohms	3.333k Ohms	2.500k Ohms	1.667k Ohms

- $dR_T/dT = -150$  Ohms/°C.

You then perform a series of experiments to explore the thermistor self-heating of your system and to determine the best bias voltage  $V_b$

**Experiment 1:** With  $V_b = 1$  volt and the thermistor in **water** at 20°C, you adjust  $R_1$  to make the amplifier output  $V_0 = 0.000$  volts. (Assume that there is no self-heating in water with  $V_b = 1$  volt)

- (4 points) What are the values of  $R_1$  and  $R_T$ ?
- (4 points) What electrical power is consumed by the thermistor?

**Experiment 2:** You then move the thermistor to **air** at 20°C, wait a while, and find that the amplifier output  $V_0 = 0.0075$  volts. ( $V_b = 1$  volt)

- (5 points) What is the thermistor resistance  $R_T$ ?
- (4 points) What is the temperature of the thermistor?
- (4 points) What electrical power is consumed by the thermistor?

**Experiment 3:** With the thermistor in air at 20°C, you increase  $V_b$  to 10 volts, wait a while, and find that the amplifier output  $V_0 = 8.333$  volts.

- f. (5 points) What is the thermistor resistance  $R_T$ ?
- g. (4 points) What is the temperature of the thermistor?
- h. (4 points) What electrical power is consumed by the thermistor?
- i. (5 points) From your calculations of experiment 3, what is the thermal dissipation coefficient in mW per  $C^\circ$ ?
- j. (6 points) Comment on the design factors that determine the approximate **minimum** and **maximum** bias voltages for this application.

## PROBLEM 2 (45 points)

You are assigned the task of designing a truck scale for the North Dakota Department of Transportation. The scale consists of a large steel plate at the road level sitting on top of a large steel cylinder. When a truck drives onto the plate the steel cylinder is slightly compressed along its axis. The ambient temperature is expected to vary from  $-20^\circ\text{C}$  to  $+40^\circ\text{C}$ . The thermal expansion coefficient of the steel cylinder is  $10\text{ppm}/C^\circ$ .

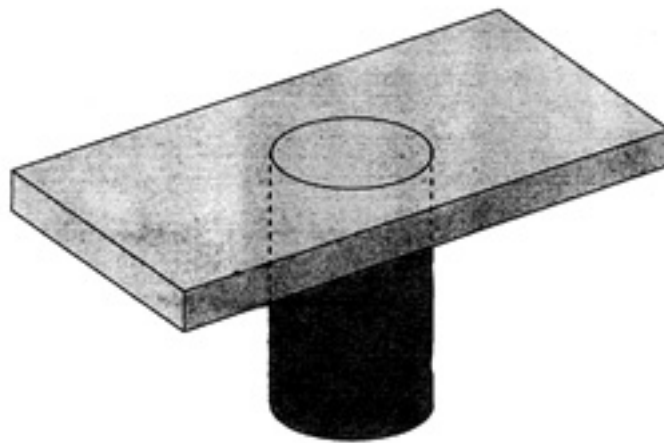

**Design a system that meets the following requirements:**

- The system should produce output that is proportional to the weight of the truck.
- The maximum truck weight of 10,000 kg should produce an output of 10 volts.
- Trucks are to be weighed to an accuracy of 100 kg over the full temperature range.

**Assume the following:**

- You have decided to use four metal foil strain gauges with gauge factor  $G_S = 2.00$  and a unstrained resistance of 100 Ohms (similar to those used in the 145L lab)
- You may use any electronic component in the 145L lab, but keep it simple.
- You cement the strain gauges (to whatever you decide to place them) at a temperature of  $20^\circ\text{C}$ . At this temperature, the strain is zero.
- The maximum truck weight of 10,000 kg produces a compressive strain  $\Delta L/L = -0.2\%$
- The steel cylinder is hollow so the load only compresses the steel cylinder along its length and changes in diameter are negligible.
- All dimensions (eg. length and diameter) change equally when the temperature changes.
- The steel plate weighs 1,000 kg.
- The resistivity  $\rho$  of the strain gauge metal foil does not depend on temperature.

**a.** (20 points) Sketch your circuit, showing all essential components. **Also**, sketch the placement and orientation of the four strain gauges on the previous drawing.

*No (b.) given on exam*

**c.** (5 points) With no load on the scale, what are the resistances of the 4 strain gauges and the voltages at 3 key points in your circuit (2 bridge outputs, 1 amplifier output) at  $+20^\circ\text{C}$ ?

**d.** (10 points) With the maximum 10,000 kg load on the scale, what are the resistances of the 4 strain gauges and the voltages at 3 key points in your circuit at  $+20^\circ\text{C}$ ?

**e.** (10 points) With no load on the scale, what are the resistances of the 4 strain gauges and the voltages at 3 key points in your circuit at  $-20^\circ\text{C}$ ?

**PROBLEM 3 (45 points)**

**a.** (5 points) What function is the Ground Fault Interrupter Circuit designed to do?

**b.** (5 points) Describe how a Ground Fault Interrupter Circuit works.

**If you have any questions about these online exams  
please contact <mailto:examfile@hkn.eecs.berkeley.edu>**