

Name _____ SID _____

CS 152 Computer Architecture and Engineering
Fall 1998
R. W. Brodersen

Midterm # 2

Please write your name and SID on *each page* of this exam. The number of points for each problem is show below. You have three hours for this exam – budget your time accordingly.

#	Possible	Score
1	35	
2	15	
3	25	
4	25	
Total	100	

Problem 1: Multi-cycle Datapath [40 points]

For this problem, please refer to the multi-cycle datapath drawn below. The ALU can perform either $A+B$ or $A-B$ and the output NEG indicates if the result is negative. The NEG signal, after being delayed one cycle, is fed through the controller and can be used to conditionally write to any of the four main registers (P, A, R, or T). The control state machine is reset to 0 every time the P register (program counter) is written, otherwise, the state machine advances by one every cycle. Each instruction for this multi-cycle datapath contains two immediates, termed C1 and C2, each of which is independently sign-extended. Registers and memories are clocked and have a 'CLK' input shown (but not connected). The clock only applies to the write operation of DMEM, and has no effect on the read operation. All write enables are active high.

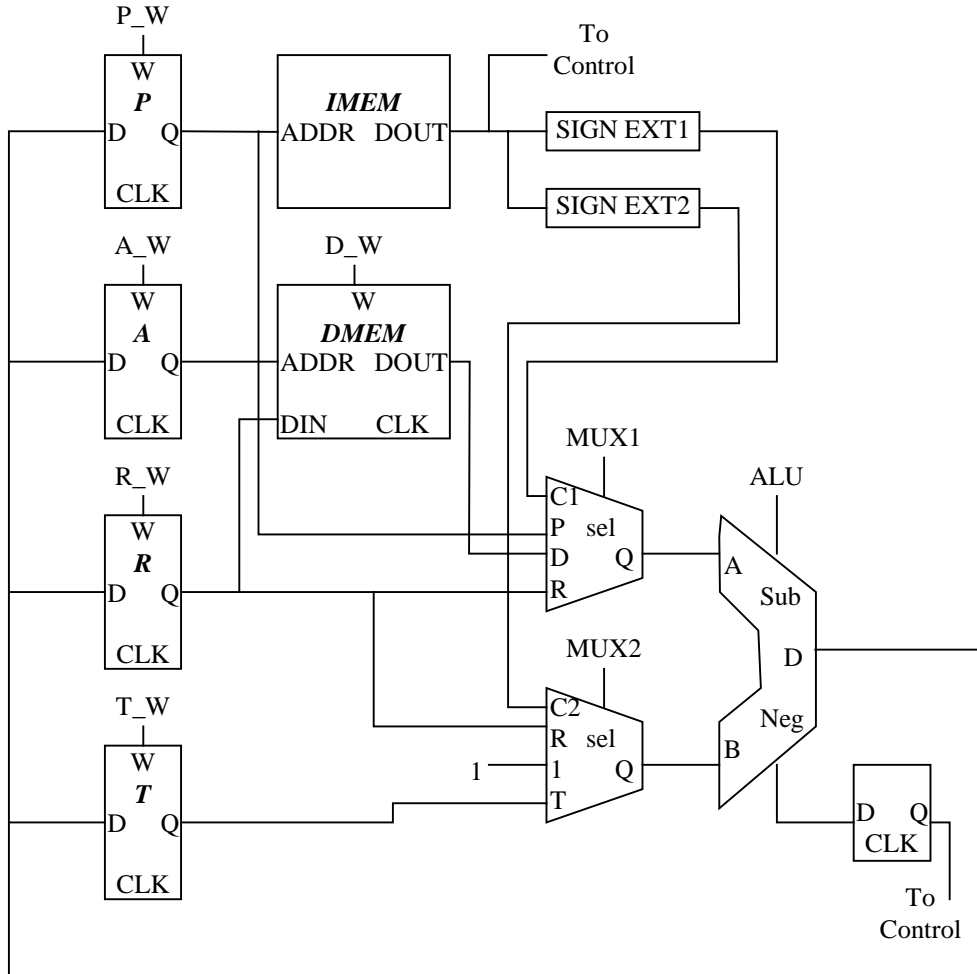

a) Micro-Programming

Fill in the values missing in the table below for the given instructions. The RTL specification for the instructions is given. The phrase “if NEG” indicates that the register write should be performed only if the result of the previous ALU operation was negative; use the keyword “NEG” in the table below to indicate this behavior.

ADD R, R, C1 (add immediate)

R <- R+C1

P <- P+1

SBN R, C1, C2 (subtract and branch if neg)

R <- C1-R

P <- P+C2 if NEG

Else P <- P+1

SWP T, [R+C2], R (swap memory data)

A <- R+C2

T <- R-R

T <- M[A]+T

M[A] <- R

P <- P+1

IIG R, T, C1 (increment R if T>C1)

_ <- C1-T (the result is not written to a register)

R <- R+1 if NEG

P <- P+1

Inst./Cycle	P_W	A_W	R_W	T_W	D_W	MUX1	MUX2	ALU
ADD	0	0	1	0	0	C1	R	ADD
2	1	0	0	0	0	P	1	ADD
SBN	0	0	1	0	0			
2	NEG	0	0	0	0			
3	1	0	0	0	0			
SWP	0				0	R	C2	ADD
2	0				0	R	R	SUB
3	0				1	D	T	ADD
4	1				0	P	1	ADD
IIG								
2								
3								

b) Datapath Delay

Using the delay values given below, calculate the minimum cycle time for the multi-cycle datapath. Assume there is no stall time between the completion of one instruction and the initiation of the following instruction.

Component	Delay
Sign-Extender	1 ns
4-1 Mux	2 ns
ALU	4 ns
IMEM	2 ns
DMEM	4 ns
Register Clk-Q	1 ns
Register Setup	2 ns
Register Hold	4 ns
Control Logic	3 ns

Minimum cycle time: _____

c) Complex Micro-programming

Fill in the given table with a micro-code implementation of the BEQ. The definition of BEQ is as follows:

BEQ R, C1, C2: Branch to P+C2 if register R equals constant C1. The value in register R remains unchanged; the value in register T is not preserved.

Hint: the RTL operation 'T <- R-R' will always place the value 0 in register T.

Inst./Cycle	P_W	A_W	R_W	T_W	D_W	MUX1	MUX2	ALU
BEQ								
2								
3								
4								
5								
6								
7								
8								
9								
10								

For parts d) and e), we consider a single-cycle implementation of the multi-cycle datapath that is only capable of executing following four instructions:

Inst./Cycle	P_W	A_W	R_W	T_W	D_W	MUX1	MUX2	ALU
BAD	0	0	0	1	0	R	T	ADD
2	1	0	0	0	0	P	C2	ADD
BLE	0	0	0	0	0	R	T	SUB
2	NEG	0	0	0	0	P	C2	ADD
3	1	0	0	0	0	P	1	ADD
LAD	0	1	0	0	0	R	T	ADD
2	0	0	1	0	0	D	C2	ADD
3	1	0	0	0	0	P	1	ADD
SIG	0	0	0	0	0	R	T	SUB
2	0	0	NEG	0	0	R	T	SUB
3	1	0	0	0	0	P	1	ADD

d) Multi-Cycle CPI

Assuming the instruction mix in the table below, how much slower can the minimum cycle time of the single cycle implementation be compared to the multicycle implementation while maintaining equal performance? Give your answer relative to the cycle time of the multi-cycle version (i.e., "The single-cycle datapath can have a cycle-time that is 100 times slower")

Instruction	Frequency
BAD	10%
BLE - taken	30%
BLE - not taken	20%
LAD	30%
SIG	10%

Allowable increase in cycle time: _____

e) Multi-Cycle To Single-Cycle Conversion:

Fill in the missing pieces of the new single-cycle datapath below so that it is capable of executing the four multi-cycle instructions (BAD, BLE, LAD, and SIG), each in a single cycle. Use the micro-code to determine the function of each instruction, as necessary. If you do not need a component that is already shown in the diagram, cross it out. You may only add MUXEs (any size), adders, and wires. Use the minimum hardware required (you do not need to support any instructions given in part a); consider adders and MUXEs to be of equivalent area. You do not need to show any control signals.

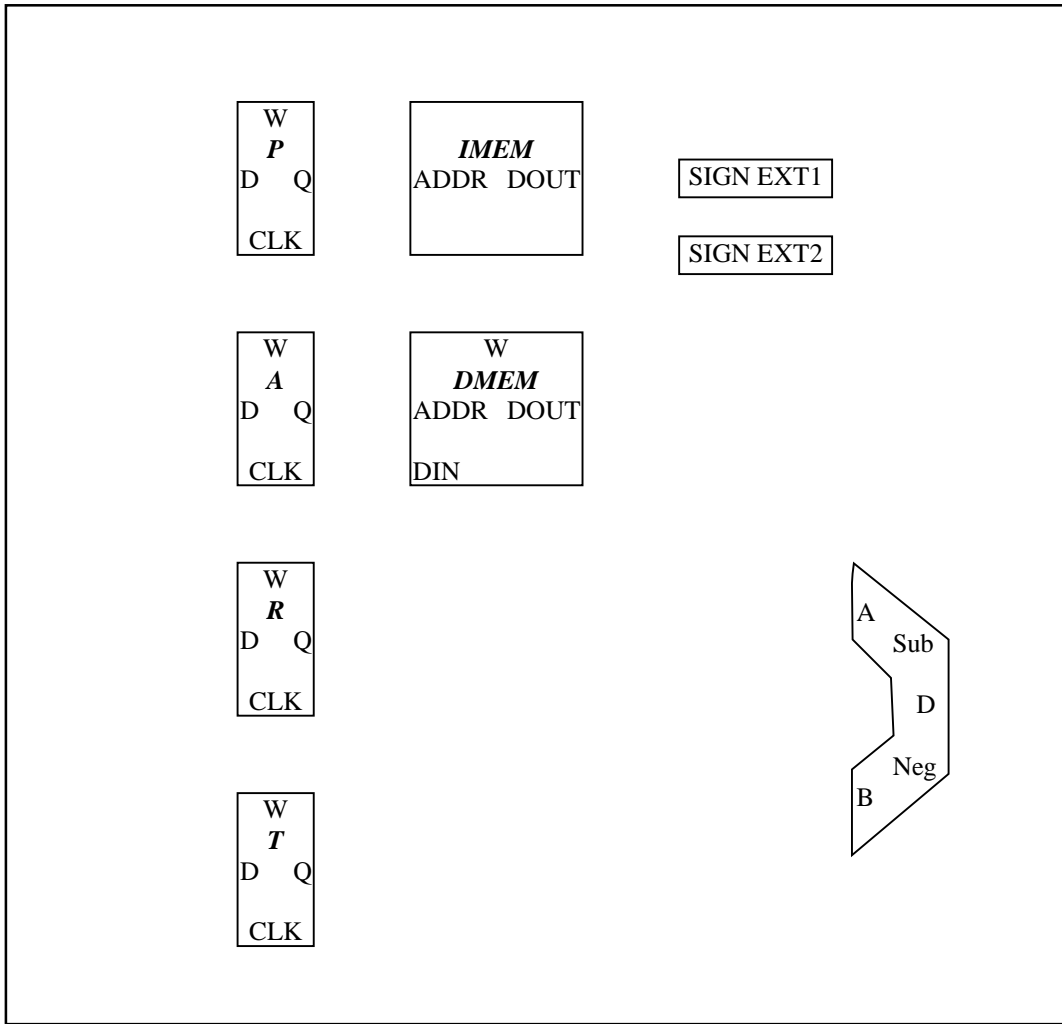

Problem 2: Pipelining, Datapath Hazards, Forwarding

You work for the CPU giant, NoTel. The marketing department has decided that, even though the flagship CPU has the best performance on the market, it is difficult to sell because it has a low clock rate. The other engineers have decided that the best way to increase clock rate is to split the standard, MIPS-style 5-stage pipeline into a 7-stage pipeline. This will be accomplished by splitting the EXE stage into EXE1 and EXE2. Likewise for the MEM stage, there is now MEM1 and MEM2. Assume you cannot access any useful data in the position between the newly split stages, and you cannot forward into the middle of 2 EXE or MEM stages. The new pipeline, repeated a few times, is shown below.

This, of course, expands the number of forwarding paths. As a new designer, you get the job of designing the forwarding scheme. You decide to first do some test cases.

a) On the pipelines shown below, draw in the forwarding paths that are exercised in each cycle. The instruction shown to the left of each pipeline is the instruction that is issued (enters the IF stage) in the cycle where the IF stage resides in the picture, e.g. the first ADD is issued in cycle 1, the first SUB is issued in cycle 2, etc. Show only the forwarding paths that are used by the code shown, not all the possible forwarding paths in the processor. It is possible that stalls will be required to resolve the hazard, which you will enumerate in part b). Assume that the register file can do a write before a read in the same cycle.

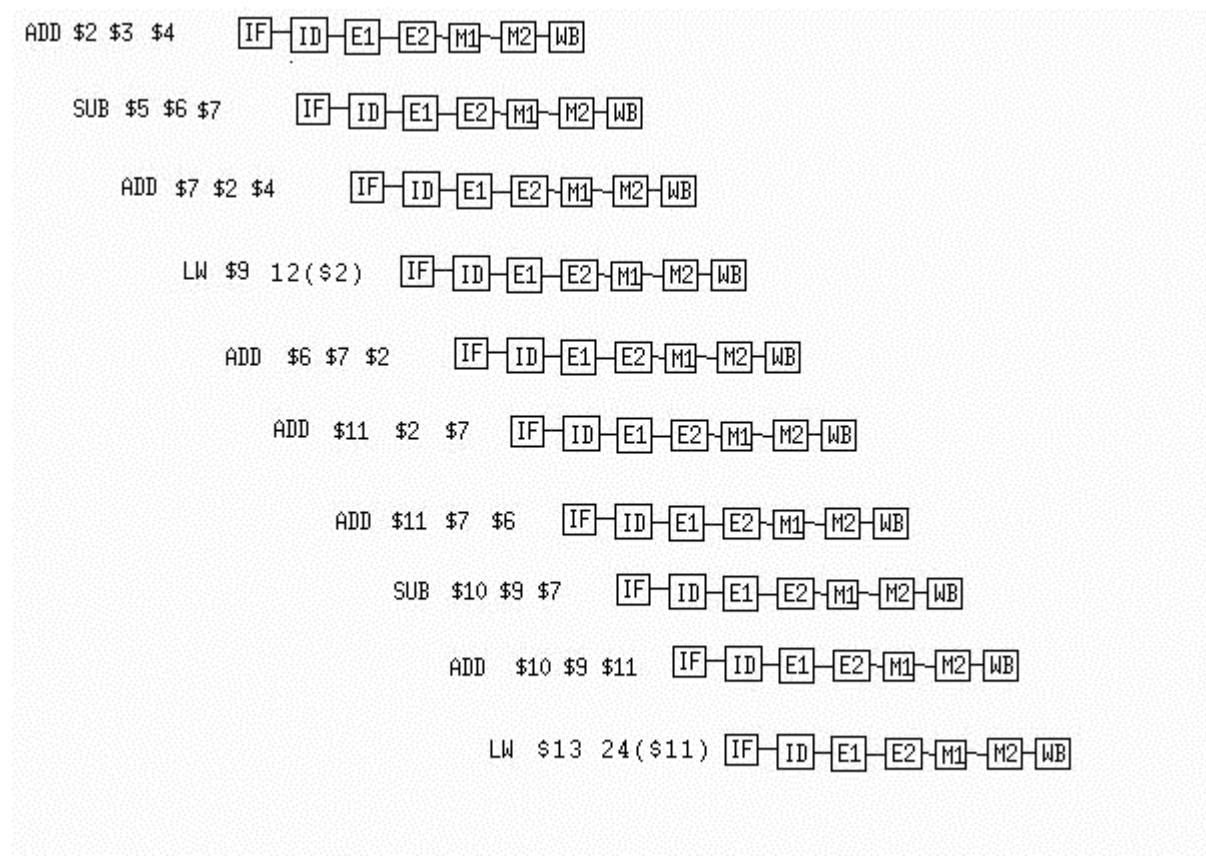

b) In the course of working through the above instructions, and the forwarding paths that are needed, you realized that there are still some cases where no amount of forwarding can resolve the dependencies, the data is simply not ready by the time the next instruction needs it. The only way to resolve the hazard is to insert a bubble into the pipeline, stalling the next instruction, which needs the data, while allowing the current instruction that is using the data, to continue processing. You have come up with some instruction sequences with these problems, and now you have to figure out how many bubbles need to be inserted in each case. One bubble is equivalent to stalling for one clock cycle. The cases of interest are shown in the table below. Fill in the total number of bubbles that need to be inserted for the block of code shown, in order to resolve all hazards.

Instruction Sequence	Total Number of Bubbles
ADD \$2, \$3, \$4 SUB \$7, \$2, \$3	
LW \$5, 24(\$6) ADD \$9, \$8, \$5 SUB \$6, \$9, \$5	
LW \$5, 12(\$13) LW \$5, 16(\$8)	
LW \$4, 32(\$3) LW \$5, 32(\$4) LW \$6, 32(\$5)	
ADD \$7, \$4, \$2 LW \$4, 0(\$7)	
SW \$7, 0(\$12) XOR \$2, \$7, \$4	

c) The hardware group has finally built an actual CPU, based on your testing from above. It is your job to exhaustively test the chip. However, the test board for the CPU has only a small ROM on it to store the test code. Write the test code that exercises every forwarding path in the CPU. You do not need to test the bubble cases.

Problem 3: Cache and Virtual Memory

a) Design a 3-way set associative cache given the following constraints:

- Total size of 24 words
- Block size of 4 words
- Word length of 16 bits
- Total addressable memory space is 1024 (1K) word-addressed words
- Write-back / Write-allocate policy
- Least frequently used (LFU) replacement policy

i.) How many comparators are required in this design, and what are their widths (in bits)? Explain your reasoning.

ii.) How many registers are required in this design, and what are their widths (in bits)? Explain your reasoning.

iii.) What status bits are needed for each block? Explain your reasoning.

iv.) Draw a diagram of the address bits in this machine, and indicate what the bits are used for in this cache.

v.) Fill in the table below, indicating whether each request is a cache hit or miss:

Address	3	1	7	9	5	18	13	11	2	6	27	15	22	30
H/M														

vi.) Draw a table below that represents the final state of the cache.

Name _____ SID _____

- f) Consider a machine with a three-tiered virtual memory hierarchy as described below. Note that the sum of hit rates is 100%, so no misses occur at the physical disk level.

Level / Memory Type	L1 Cache On-die SRAM	L2 Cache Off-chip SRAM	Main Memory DRAM	Physical Disk IDE Hard Drive
Hit Delay	1 cycle	4 cycles	15 cycles	500,000 cycles
Hit Rate	15.7%	28.8%	55.4%	0.1%

- i.) Calculate the CPI if memory accesses total 20% of the instruction count and all other instructions take one cycle.
- ii.) Calculate the time required to load 1000 words from disk if the CPU frequency is 100MHz, all instructions are LW, and there is a 9ms fixed access time for any request from the physical disk. Assume that the hit rates above apply.

Problem 4

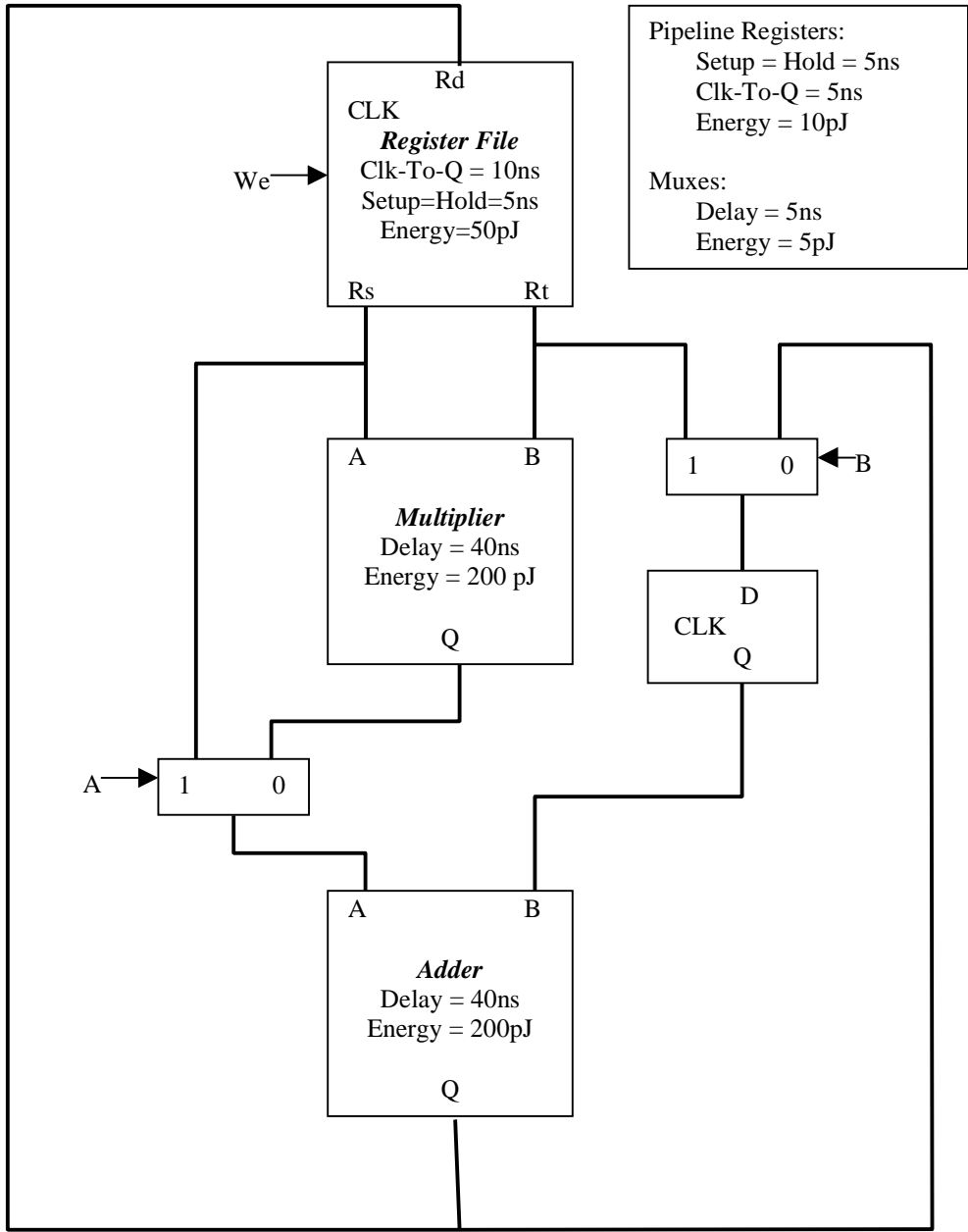

The energy and delay is for 5 volt operation and the energy is the dissipation per cycle.

This problem uses the datapath above to execute the following program:

```

sum1 = 0
sum2 = 0
FOR I = 1,2 DO
{sum1 = sum1 + a[i]b[i]
  sum2 = sum2 + a[i]}
    
```

Name _____ SID _____

f) If the voltage is reduced. all the delays, setup and hold times increase by the following formula:

$$T_{\text{delay}}(V_{\text{supply}}) = T_{\text{delay}}(5 \text{ volt}) * [4/(V_{\text{supply}} - 1)]$$

By reducing the voltage to the point where the execution time is the same as before the pipeline register was added, what is the energy consumed. What is the power dissipation?

Name _____ SID _____